

Spare part's book **10**



SE 2.5i-FR

SE 3.0i-FR

SX 2.5i-F

SHERCO

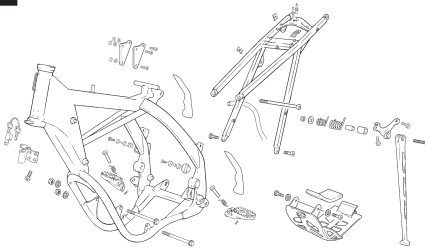
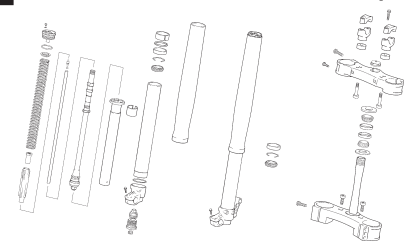
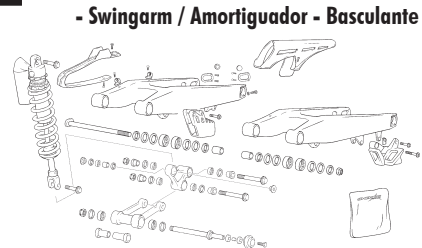
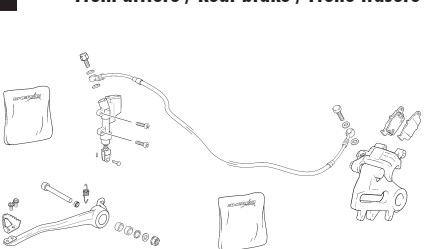
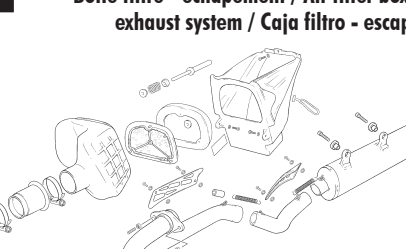
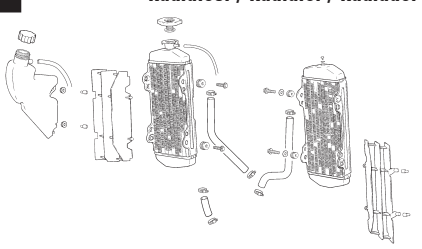
Motorcycles

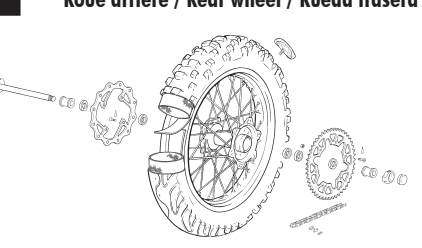
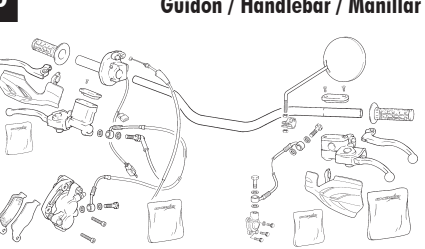
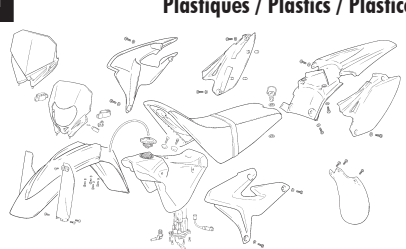
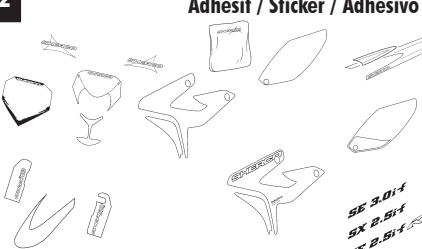
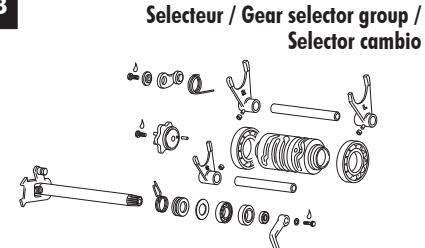
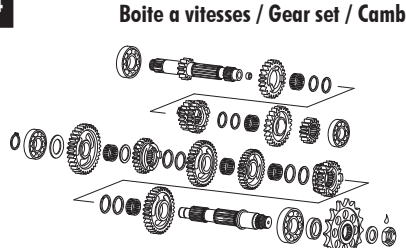
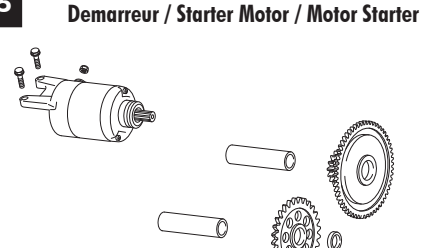
<p>1 Cadre / Frame / Chasis</p>  <p>pag. 1 - 2</p>	<p>2 Fourche / Fork / Horquilla</p>  <p>pag. 3</p>	<p>3 Amortisseur - Bras oscillant / Rear Shock - Swingarm / Amortiguador - Basculante</p>  <p>pag. 4 - 5</p>
<p>4 Frein arriere / Rear brake / Freno trasero</p>  <p>pag. 6</p>	<p>5 Boite filtre - echapement / Air filter box - exhaust system / Caja filtro - escape</p>  <p>pag. 7</p>	<p>6 Radiateur / Radiator / Radiador</p>  <p>pag. 8</p>
<p>7 Faisceau électrique / Electrical system / Instalación eléctrica</p>  <p>pag. 9 - 10</p>	<p>8 Roue avant / Front wheel / Rueda delantera</p>  <p>pag. 11</p>	<p>9 Roue arriere / Rear wheel / Rueda trasera</p>  <p>pag. 12</p>
<p>10 Guidon / Handlebar / Manillar</p>  <p>pag. 13</p>	<p>11 Plastiques / Plastics / Plásticos</p>  <p>pag. 14 - 15</p>	<p>12 Adhesif / Sticker / Adhesivo</p>  <p>SE 3.01-f SX 2.51-f SE 2.51-f</p> <p>pag. 16</p>
<p>13 Selecteur / Gear selector group / Selector cambio</p>  <p>pag. 17</p>	<p>14 Boite a vitesses / Gear set / Cambio</p>  <p>pag. 18 - 19</p>	<p>15 Demarreur / Starter Motor / Motor Starter</p>  <p>pag. 20</p>

16 Groupe carters / Crankcase assembly / Grupo carters

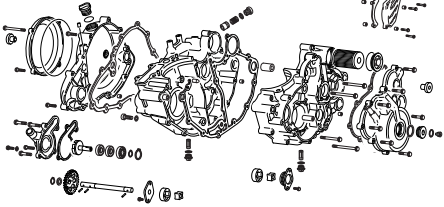

pag. 21 - 22

17 Villebrequin assemble / Crankshaft assembly / Cigüeñal biela

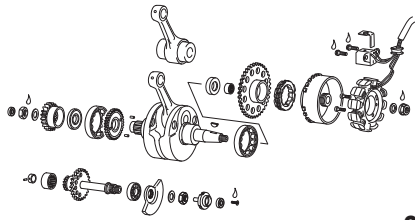

pag. 23

18 Embrayage / Clutch / Embrague

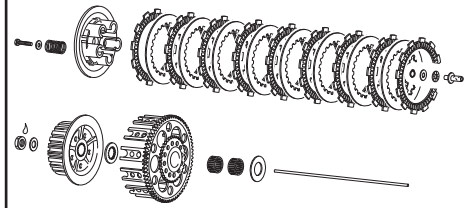

pag. 24

19 Cylindre / Cylinder / Cilindro

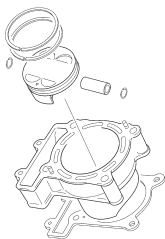

pag. 25

20 Culasse / Cylinder head / Culata

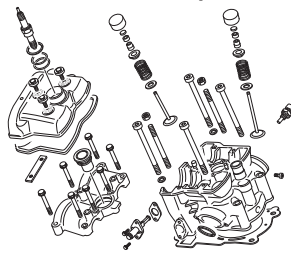

pag. 26 - 27

21 Distribution / Camshaft and drive assembly / Distribución

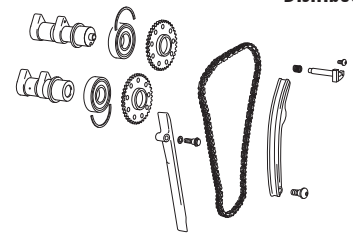

pag. 28

22 Corps injection / Injector body / Cuerpo inyección

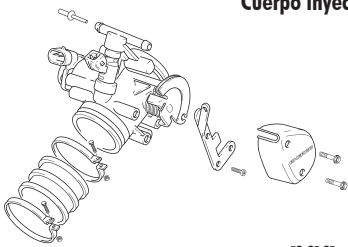

pag. 29

23 Outillage / Tools / Utillajes

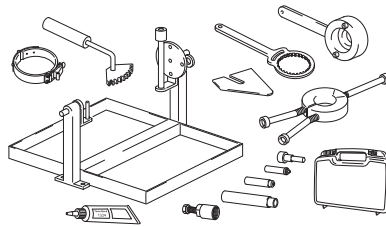

pag. 30

Cadre / Frame / Chasis

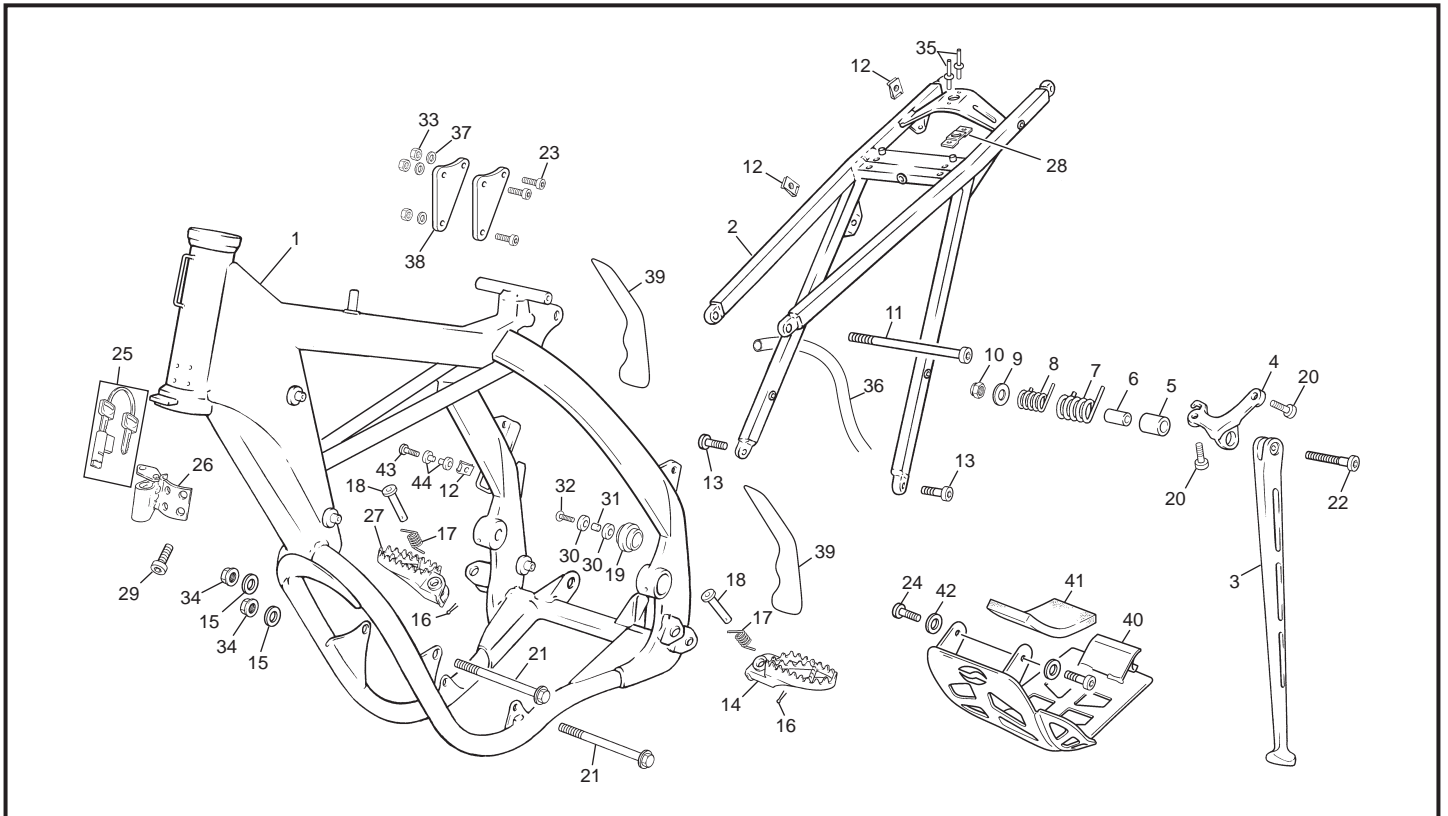

POS.	SE/SX 2.5 / 3,0i F/R	FRANÇAIS	ENGLISH	ESPAÑOL
1	2340	CADRE	FRAME	CHASIS
2	0224	BERCEAU ARRIERE	REAR SUB FRAME	SOPORTE SILLÍN
3	0300	BEQUILLE ALU	SIDE STAND ALU	CABALLETE ALUMINIO
4	0301	SUPPORT DE BEQUILLE	STAND HOLDER	SOPORTE CABALLETE
5	0481	ENTRETOISE RESSORT BEQUILLE	STAND SPACER E	CASQUILLO CABALLETE
6	0516	ENTRETOISE INT BEQUILLE	SPACER INT STAND	CASQUILLO INT CABALLETE
7	0479	RESSORT BEQUILLE EXT	SPRING STAND EXT	MUELLE CABALLETE EXT
8	0305	RESSORT DE BEQUILLE INT	STAND SPRING INT	MUELLE CABALLETE INT
9	M320	RONDELLE 10 X 30 X 2.5	WASHER 10X30X2.5	ARANDELA 10X30X2.5 DIN 9021
10	M304	ECROU NYLSTOP M10 0368.10	NUTNYLSTOPM10	TUERCA NYLSTOP M10
11	0603	VIS CHC M8X124 BERCEAU ARR	SCREW BHCM 8X124	TORNILLO M8X124
12	M308	ECROU CLIP M6	NUT CLIP M6	TUERCA CLIP M6
13	0607	VIS CHC EPAULE M8 X 16	SCREW BHC M8 X 16	TORNILLO ULS CON VALONA M8 X 16
14	0227	REPOSE PIED GAUCHE	LEFT FOOT REST	ESTRIBO IZQUIERDO
15	M315	RON. DIAM 10 X 1.5 AXE REPOSE PIED	WASHERDIAM 10X1.5	ARANDELA DIAM 10 X 1.5 DIN 125 A
16	0240	GOUPILLE 3.2X20	COTTER	PASADOR DIN 94 3.2X20
17	0229	RESSORT REPOSE PIED	FOOT REST PIN	MUELLE ESTRIBERA
18	0230	AXE REPOSE PIED	FOOT REST AXEL	EJE ESTRIBERA
19	0231	GALET DE CHAINE	CHAIN GUIDE ROLLER	RODILLO CADENA
20	C413	VIS CHC 8 X 16	SCREW CHC 8 X 16	TORNILLO M8 X 16
21	1672	AXE MOTEUR 10 X 135	ENGINE MOUNTING BOLT 10 X 135	EJE MOTOR 10 X 135
22	0482	VIS BEQUILLE	STAND SCREW	TORNILLO CABALLETE
23	0580	VIS THEP M8 X 40	SCREW THEP M8 X 40	TORNILLO THEP M8 X 40
24	0546	VIS TH EP 6 X 20	SCREW TH EP 6 X 20	TORNILLO TH EP 6X20
25	0225	ANTIVOL DE DIRECTION	STEERING LOCK KEY	ANTI ROBO DIRECCIÓN
26	0449	SUPPORT ANTIVOL DIRECTION	STEERING LOCK HOLDER	SOPORTE ANTI ROBO
27	0226	REPOSE PIED DROIT	RIGHT FOOT REST	ESTRIBO DERECHO
28	0531	PLAQUE DZUS	PLAQUE DZUS	RECEPTACULO DZUS
29	0562	VIS ANTIMANIPULATION ANTIVOL	TAMPER PROOF SCREW	TORNILLO ANTI MANI. ANTIRROBO
30	0577	ROULEMENT 22 X 8 X 7	BEARING 22 X 8 X 7	RODAMIENTO 22X8X7
31	0556	DOUILLE GALET CHAINE	SPACER	CASQUILLO RODILLO CADENA
32	0578	VIS TH EP M8 X 30	SCREW TH EP M8 X 30	TORNILLO THEPM8X30
33	M305	ECROU M8 NYLSTOP	MUT M8 NYLSTOP	TUERCA M8 NYLSTOP
34	0703	ECROU NYLSTOP EPAULE M10	NUT NYLSTOP M10	TUERCA NYLSTOP CON VALONA M10

Cadre / Frame / Chasis

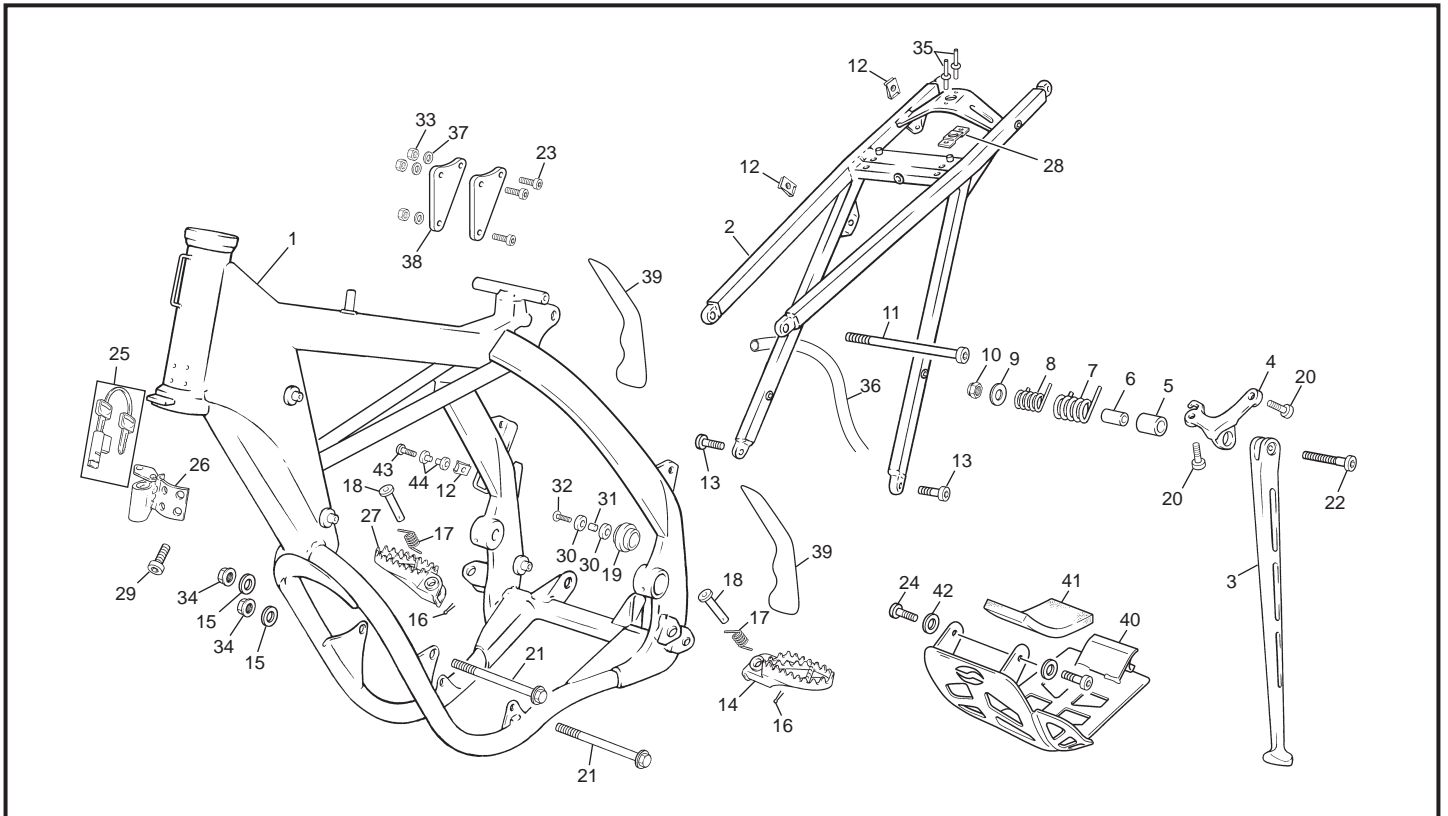

POS.	SE/SX 2.5 / 3,0i F/R	FRANÇAIS	ENGLISH	ESPAÑOL
35	0701	RIVET 3X10	RIVET 3X10	REMACHE 3X10
36	1962	DURITE RENIFLARD HUILE	OIL BREATHING HOUSER 850 END 450	TUBO VENTILACIÓN DESETE L850 450
37	C430	RONDELLE M8	WASHER M8	ARANDELA M8
38	1709	SUPPORT CULASSE	HEAD CYLINDRE SUPORT	SOPORTE CULATA
39	1941	PROTECTEUR CADRE	FRAME PROTECTOR	PROTECTOR CHASIS
39	2961	PROTECTEUR CADRE JEUX CARBONNE	CARBON FRAME PROTECTOR SET	PROT. CUADRO CARBONO END
40	1994	SABOT ALU.	SKID PLATE	PROTECTOR CARTER
40	2220	SABOT PLASTIQUE AXP RACING	SKID PLATE PLASTIC RACING 250 END	PROT. CARTER PLATIC RACING 250 END
41	1253	MOUSSE CARTER	FOAM CRANKCASE	ESPUMA MOTOR
42	C427	RONDELLE M6X15	WASHER M6X15	ARANDELA M6X15
43	0547	VIS THEP M6x30	SCREW THEP M6x30	TORNILLO THEP M6x30
44	0274	SILENBLOC SILENCIEUX	RUBBER SILENCER	GOMA SILENCIOSO

Fourche / Fork / Horquilla

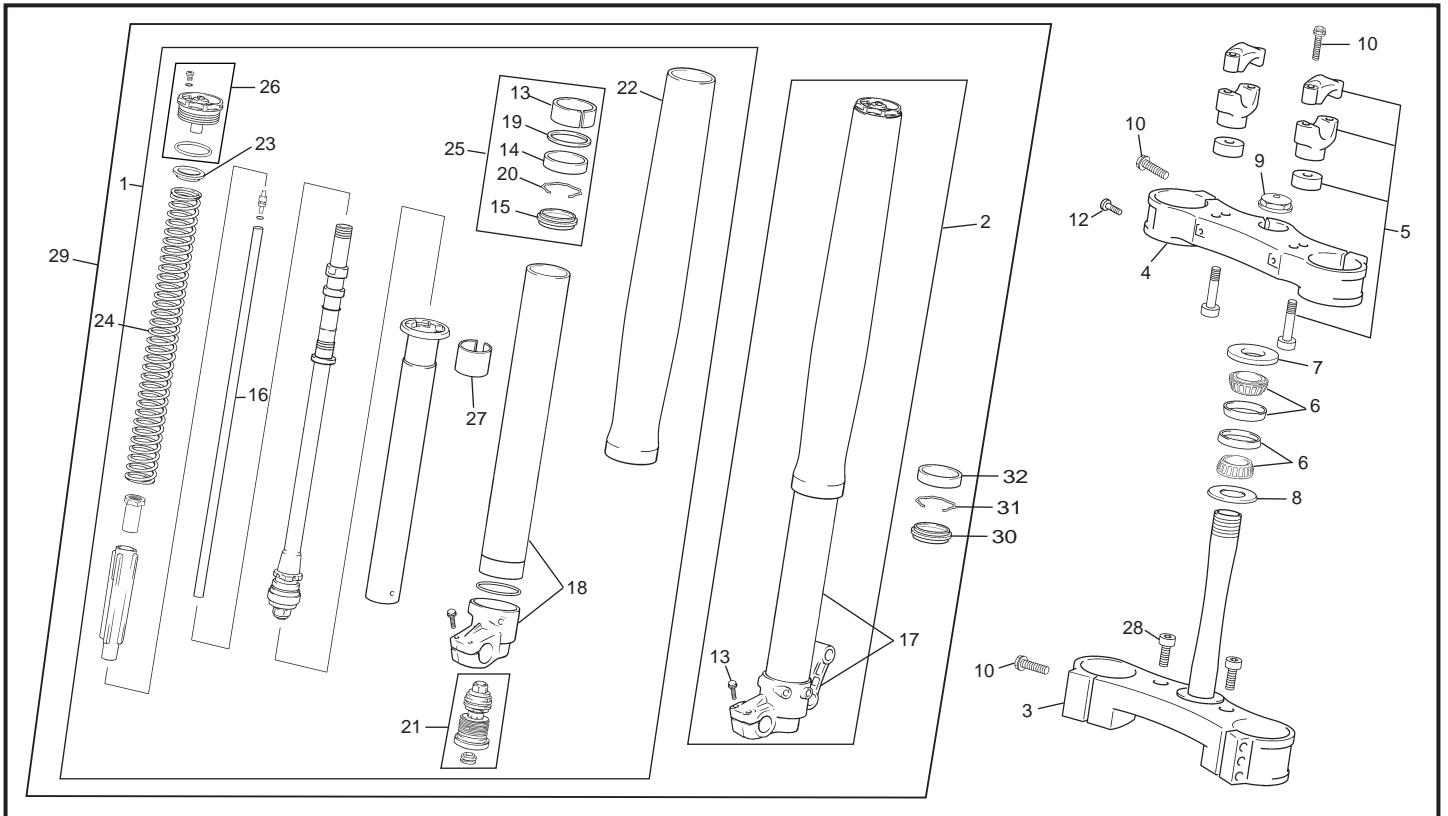

POS.	SE 2.5i/3.0F	SE 2.5i/3.0i FR	SX 2.5i F	FRANÇAIS	ENGLISH	ESPAÑOL
1	2089	-----	-----	JAMBE DROITE CPL PAIOLI Ø46	RIGHT FORK LEG PAIOLI Ø46	BARRA HORQUILLA DER. PAIOLI Ø46
2	2088	-----	-----	JAMBE GAUCHE CPL PAIOLI Ø46	LEFT FORK LEG PAIOLI Ø46	BARRA HORQUILLA IZQ. PAIOLI Ø46
3	1903	1716	1716	T FOURCHE INF.	BOTTON PLAT FORK	PLATINA INF. HORQUILLA
4	1902	1715	1715	T FOURCHE SUP.	UPPER PLAT FORK	PLATINA SUP. HORQUILLA
5	1413	1413	1413	BRIDES GUIDON CPL	HANDLEBAR CLAMPS	BRIDAS MANILLAR CPL
6	0353	0353	0353	ROULEMENT DIRECTION 320/28X/Q	BEARING 320/28X/Q	RODAMIENTO DIRECCIÓN 320/28X/Q
7	0354	0354	0354	PROTECTEUR SUP COLONNE DIREC.	BEARING SHIELD	PROTECTOR COJINETE DIRECCIÓN
8	0410	0410	0410	JOINT DIRECTION INF	SEAL	JUNTA DIRECCIÓN INF.
9	0460	0460	0460	ECROU PIVOT DIRECTION	STEERING SHAFT NUT	TUERCA EJE DIRECCIÓN
10	0580	0580	0580	VIS TH EP M8X40	TRIPLE CLAMP SCREWS	TORNILLO THEP M8X40
11	0547	0547	0547	VIS TH EP 6X30	SCREW TH EP 6X30	TORNILLO THEP 6X30
12	0578	0578	0578	VIS TH EP M8X30	SCREW TH EP M8X30	TORNILLO THEP M8X30
13	0720	-----	-----	GLACIER DU	SPACER	CASQUILLO TEFLÓN
14	0721	-----	-----	JOINT SPIE 450	FORK OIL SEAL	RETÉN
15	0722	-----	-----	CACHE POUSIENE	DUST SEAL	GUARDAPOLVO
16	1951	-----	-----	GROUPE CARTOUCHE	PUMPING DEVICE COMPL.	GRUPO CARTUHO
17	0752	-----	-----	GROUPE TUBE GAUCHE	FORK TUBE LEFT	GRUPO TUBO IZQUIERDO
18	0753	-----	-----	GROUPE TUBE DROITE	FORK TUBE RIGHT	GRUPO TUBO DERECHO
19	0754	-----	-----	RONDILLE JOINT SPIE	SEAL WASHER	ARANDELA RETÉN
20	0755	-----	-----	SERGER JOINT SPIE	SEAL CLIP	SEEGER RETÉN
21	0756	-----	-----	GROUPE REGULATEUR COMPRESION	REGULATION COMPRES. GROUP	GRUPO REGULACIÓN COMPRESIÓN
22	2104	-----	-----	GROUPE JAMBE NOIR	SIDE FORK ASSEMBLY BLACK	GRUPO BARRA NEGRO
23	0758	-----	-----	RONDILLE APUI RESSORT	PLASTIC SPACER FOR SPRING	ARANDELA APOYO MUELLE
24	1952	-----	-----	RESSORT FOURCHE	FORK SPRING	MUELLE HORQUILLA
25	0760	-----	-----	KIT JOINTS	KIT REPAIR FORK OIL SEAL	KIT RETENES
26	0761	-----	-----	GROUPE BOUCHON JAMBES	FORK CAP	GRUPO TAPÓN BARRAS
27	0762	-----	-----	DU JAMBE	DU FRICTION	RASCADOR DU
28	1945	1945	1945	VIS CHC M12X16	SCREW CHC M12X16	TORNILLO CHC M12X16
29	-----	1712	1372	FOURCHE ÖHILINS COMPLETE Ø48	COMPLET FORK ÖHILINS Ø48	HORQUILLA ÖHILINS COMPLETE Ø48
30	-----	2976	-----	CACHE POUSIENE ÖHLINS	DUST SEAL ÖHLINS	GUARDAPOLVO ÖHLINS
31	-----	2977	-----	SERGER JOINT SPIE ÖHLINS	SEAL CLIP ÖHLINS	SEEGER RETÉN ÖHLINS
32	-----	2975	-----	JOINT SPIE ÖHLINS	FORK OIL SEAL ÖHLINS	RETÉN ÖHLINS

Amortisseur - Bras oscillant / Rear Shock - Swingarm / Amortiguador - Basculante

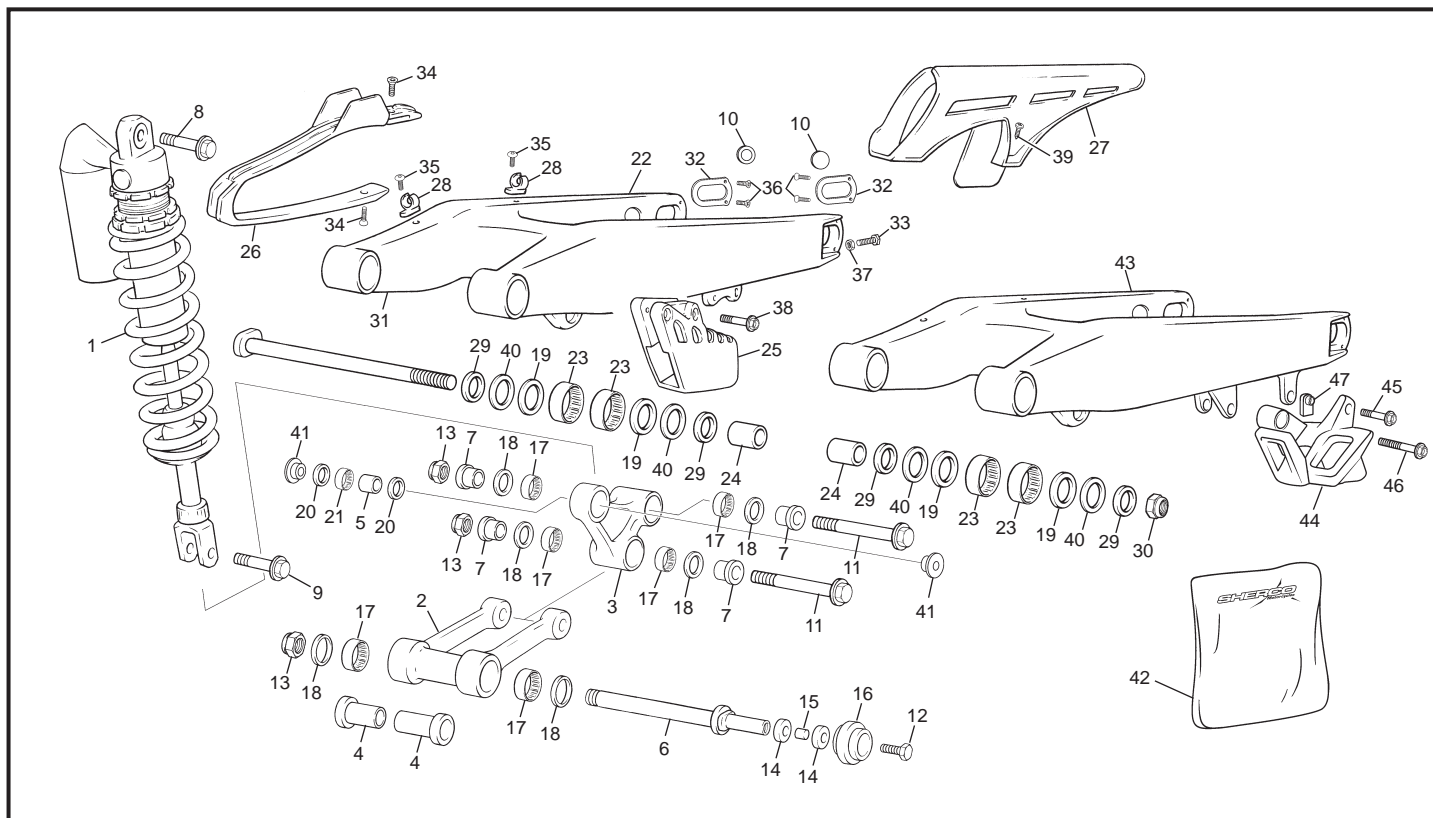

POS.	SE 2.5i/3.0F	SE 2.5i/3.0i FR	SX 2.5i F	FRANÇAIS	ENGLISH	ESPAÑOL
1	-----	1713	-----	AMORTISSEUR ÖHILINS	ÖHILINS REARSHOCK	AMORTIGUADOR ÖHILINS
1	1717	-----	1895	AMORTISSEUR SACHS	REARSHOCK SACHS	AMORTIGUADOR SACHS
2	0432	0432	0432	BIELLETTE H	LOWER LINK	BIELETA H
3	0433	0433	0433	BIELLETTE DELTA	DELTA LINK	TRAPECIO
4	1108	1108	1108	ENTRETOISE BIELLETTE H12X18X78.5	H LINK SPACER 12X18X78.5	CASQUILLO BIELETA 12X18X78.5
5	0435	0435	0435	ENTRETOISE BIELLETTE DELTA 10X20X22	SPACER 10X20X22	CASQUILLO TRAPECIO 10X20X22
6	0436	0436	0436	AXE BIELLETTE H & GALET	LOWER LINK BOLT	EJE BIELETA H
7	1107	1107	1107	ENTRETOISE BIELLETTE DELTA 12X18X33.5	DELTA LINK SPACER 12X18X33.5	CASQUILLO TRAPECIO SUSP. 12X18X33.5
8	0478	0478	0478	AXE AMORTISSEUR SUP M10X51	UPPER SHOCK BOLT	EJE SUP AMORTIGUADOR M10X 51
9	0438	0438	0438	AXE AMORTISSEUR INF M10X37	LOWER SHOCK BOLT	EJE AMORTIGUADOR INF M10X37
10	1103	1103	1103	BOUCHON BRAS OSCILLANT	COVER SWING ARM AXLE	TAPA FINAL REDONDO GRIS BASCULANTE
11	0437	0437	0437	AXE BIELLETTE DELTA M12X83.5	DELTA LINK BOLT	EJE BIELETA DELTA M12X83.5
12	0578	0578	0578	VIS TH EP M8 X 30	SCREW TH EP M8 X 30	TORNILLO THEP M8 X 30
13	0444	0444	0444	ECROU NYLSTOP EPAULE M12	NUT NYLSTOP M12	TUERCA AUTOBLOC. CON VALONA M12
14	0577	0577	0577	ROULEMENT 22 X 8 X 7	BEARING 22 X 8 X 7	RODAMIENTO 22X8X7
15	0556	0556	0556	DOUILLE GALET CHAINE	SPACER CHAIN WEEL	CASQUILLO RODILLO CADENA
16	0231	0231	0231	GALET DE CHAINE	ROLLER CHAIN GUIDE	RODILLO CADENA
17	0442	0442	0442	DOUILLE AIGUILLE JOINTIVE HN 1816	NEEDLE BEARING HN 1816	CASQUILLO AGUJAS HN 1816
18	0441	0441	0441	JOINT A LEVRES 22X28X4	OIL SEAL 22X28X4	RETÉN 22X28X4
19	0398	0398	0398	RONDELLE CALAGE 22 X 35 X 0.8	WASHER 22 X 35 X 0.8	ARANDELA 22 X 35 X 0.8
20	0294	0294	0294	JOINT A LEVRES 26X20X24	OIL SEAL 26X20X24	RETÉN 26X20X24
21	0443	0443	0443	DOUILLE AIGUILLE JOINTIVE HN2012	NEEDLE BEARING HN 2012	CASQUILLO AGUJAS HN 2012
22	0289	0289	0289	BRAS OSCILLANT	SWINGARM	BASCULANTE
23	0290	0290	0290	DOUILLES AIGUILLES HK 2216	NEEDLE BEARING HK 2216	CASQUILLO AGUJAS HK 2216
24	0291	0291	0291	ENTRETOISE INTERNE 17X22X38	SPACER 17X22X38	CASQUILLO INTERNE 17X22X38
25	0296	0296	0296	GUIDE CHAINE	CHAIN GUIDE	GUÍA CADENA
26	0297	0297	0297	PATÍN DE CHAINE	SWING ARM PROTECTOR	PATÍN CADENA
27	0298	0298	0298	CÂRTER DE CHAINE	CHAIN GUARD	PROTECTOR CADENA
28	0307	0307	0307	GUIDE DURITE FREIN AR	BRAKE HOSE CLIP	SOPORTE TUBO FRENO
29	0440	0440	0440	ENTRETOISE ETANCHEITE BRAS 22X28X5	SPACER 22X28X5	CASQUILLO BASCULANTE 22X28X5
30	C417	C417	C417	ECROU NYLSTOP M16X150	NUT NYLSTOP M16X150	TUERCA NYLSTOP M16X150
31	0451	0451	0451	AXE BRAS END 450	SWINGARM BOLT	EJE BASCULANTE
32	0457	0457	0457	TOLE PROTECTION BRAS	SWINGARM INSERT	CHAPA PROTECCIÓN BASCULANTE
33	0462	0462	0462	VIS TENDEUR DE CHAINE	CHAIN TENSIONOR SCREW	TORNILLO TENSOR CADENA

Amortisseur - Bras oscillant / Rear Shock - Swingarm / Amortiguador - Basculante

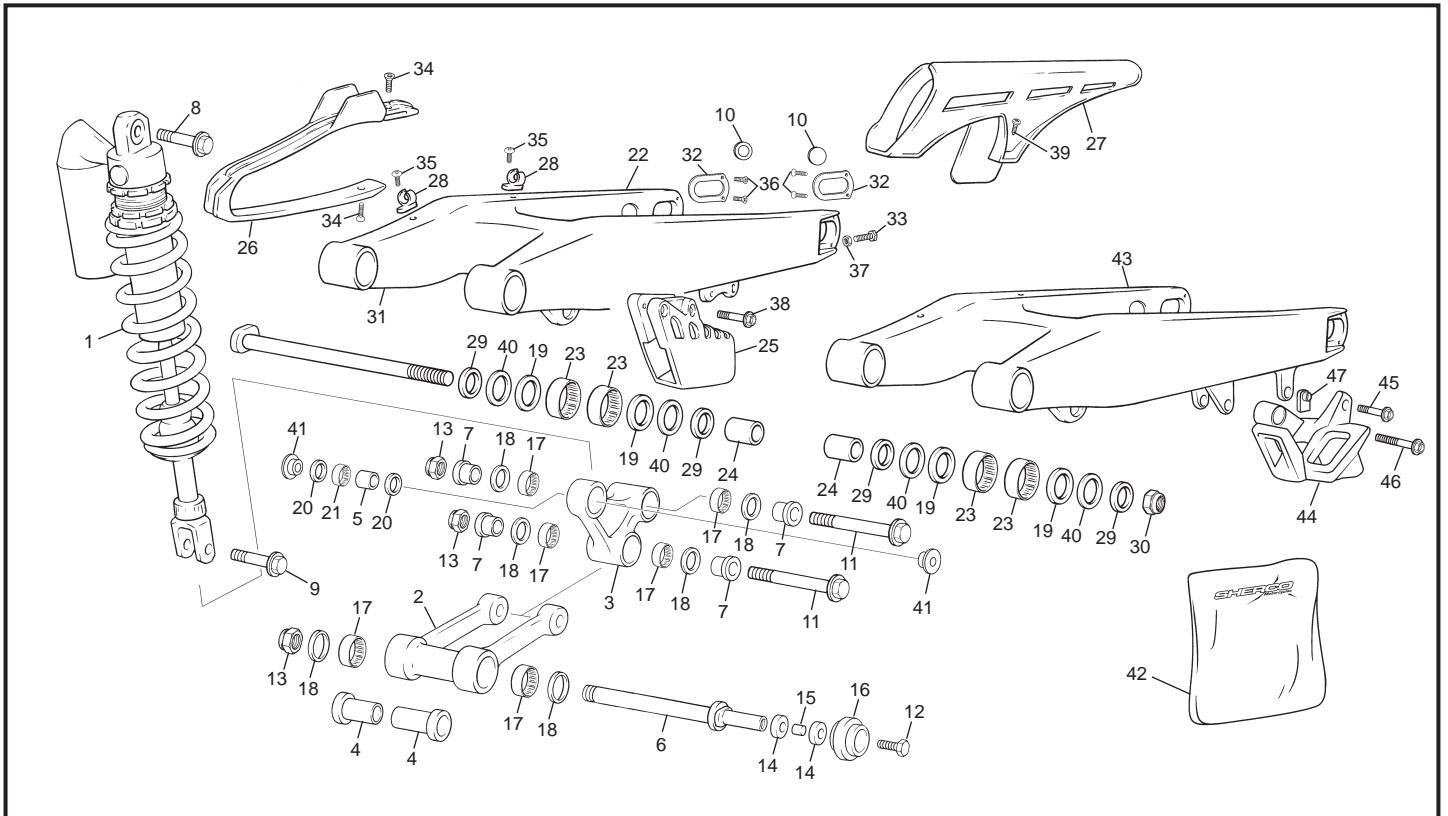

POS.	SE 2.5i/3.0F	SE 2.5i/3.0i FR	SX 2.5i F	FRANÇAIS	ENGLISH	ESPAÑOL
34	C432	C432	C432	VIS FH M6X16	SCREW FHC M6X16	TORNILLO FHC M6X16
35	M278	M278	M278	VIS BHC 6X20	SCREW BHC 6X20	TORNILLO 6X20 ULS
36	0651	0651	0651	VIS FHC M4X10	SCREW FHC M4X10	TORNILLO AVELL M4 X 10 DIN 7991
37	M272	M272	M272	ECROU EMBASE X8	HEX NUT	TUERCA CON VALONA M8
38	0580	0580	0580	VIS TH EP 8X40	SREW TH EP 8X40	TORNILLO TH EP 8X40
39	M283	M283	M283	VIS BHC 6X16 1093	SCREW BHC 6X16	TORNILLO 6X16 ULS
40	0292	0292	0292	JOINTS A LEVRES 28X35X4	OIL SEAL 28X35X4	RETÉN 28X35X4
41	-----	1371	-----	ENTRETOISE BIELLETTE DELTA ÖHILINS	DELTA LINK SPACER FOR ÖHLINS	CASQUILLO TRAPECIO PARA ÖHLINS
42	1955	-----	-----	KIT RÉPARATION AMORTISSEUR SACHS	SACHS REAR SHOCK ABSOR. REPAIR KIT	KIT REPARACIÓN AMORTIGUA. SACHS
43	-----	2246	-----	BRAS OSCILLANT RACING	SWINGARM RACING	BASCULANTE RACING
44	-----	2342	-----	GUIDE CHAÎNE RACING	CHAIN GUARD RACING	PATÍN CADENA RACING
45	-----	0546	-----	VIS THEP M6X20	SCREW THEP M6X20	TORNILLO THEP M6X20
46	-----	0549	-----	VIS THEP M6X45	SCREW THEP M6X45	TORNILLO THEP M6X45
47	-----	2343	-----	ECROU SPECIAL	SPECIAL NUT	TUERCA ESPECIAL

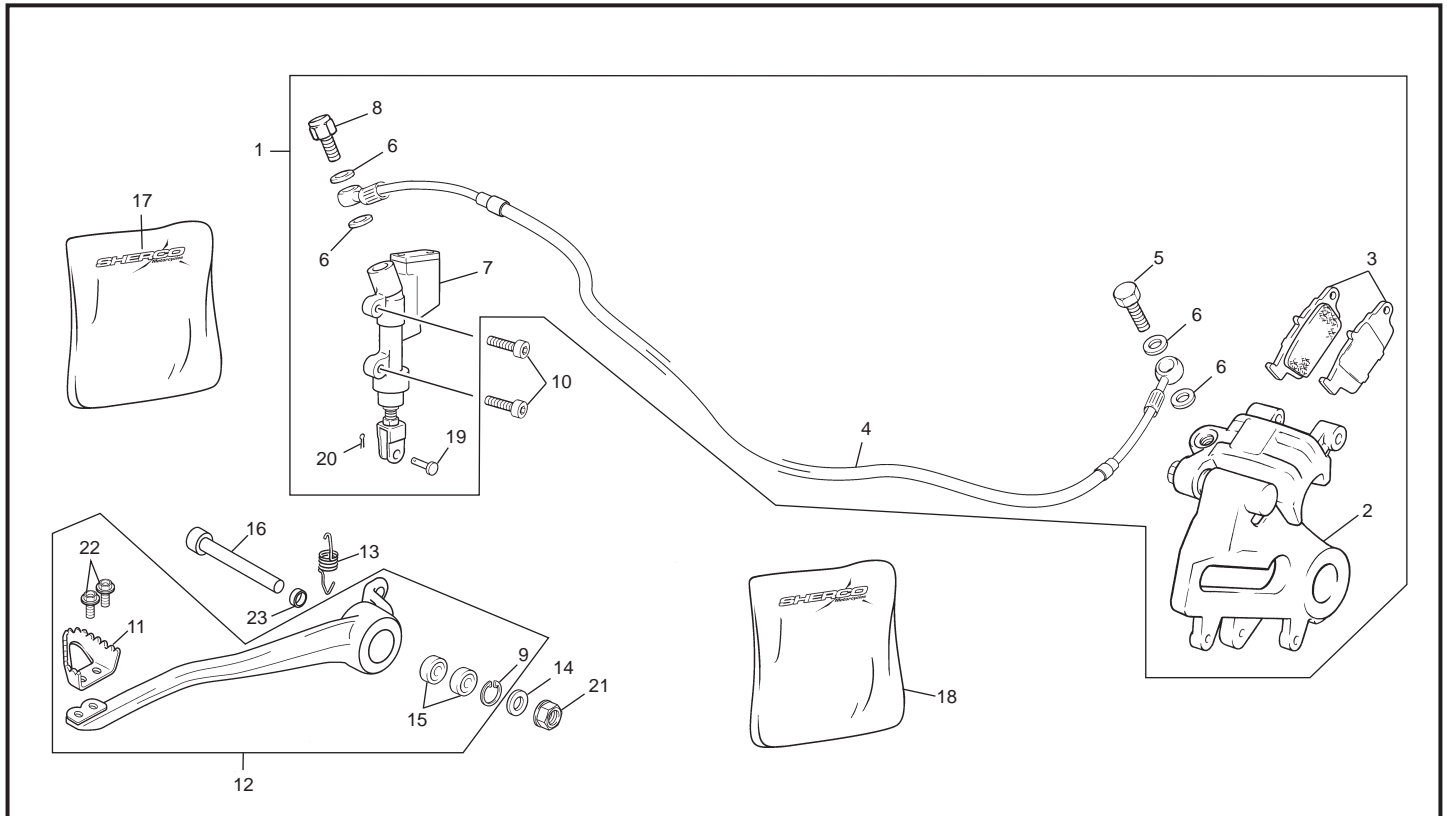
Frein arriere / Rear brake / Freno trasero

POS.	SE/SX 2.5 / 3,0i F/R	FRANÇAIS	ENGLISH	ESPAÑOL
1	1287	GROUPE FREIN AR. CPL	REAR BRAKE SYSTEM ASSY	CTO. FRENO TRASERO
2	0627	ETRIER FREIN AR	REAR CALIPER	PINZA FRENO TRASERA
3	0631	PLAQUETTES FREIN ARRIERE PAIRE	REAR BRAKE PADS (PAIR)	JUEGO PASTILLAS TRASERO
4	1278	DURITE FREIN AR	REAR BRAKE HOSE	LATIGUILLO FRENO TRASERO
5	R059	VIS RACCORD M10X21	SCREW M10X21	TORNILLO RACORD M10X21
6	R074	RONDELLE BANJO	ALUMINIUM SEAL	ARANDELA BANJO
7	1277	POMPE FREIN AR	REAR MASTER CYLINDER	BOMBA FRENO TRASERO
8	2151	VIS RACORD M10X18	SCREW M10X18	TORNILLO M10X18
9	0579	CIRCLIP 22X1	CIRCLIP 22X1	CIRCLIP 22X1
10	0546	VIS THEP 6X20	SCREW THEP 6X20	TORNILLO THEP M6X20
11	2372	EMBOUT PEDAL FREIN	POINT BREAK PEDAL	PUNTERA PEDAL FRENO
12	2325	PEDALE DE FREIN AR CPL	REAR BRAKE PEDAL	PALANCA FRENO TRASERO
13	0336	RESSORT PEDALE FREIN	REAR BRAKE LEVER SPRING	MUELLE PALANCA FRENO
14	C430	RONDELLE M8	WASHER M8	ARANDELA M8
15	0577	ROULEMENT BILLE 608.2RS	BREARING 608.2RS	RODAMIENTO 608.2RS
16	2121	VIS CHC M8X55 10.9	SCREW CHC M8X55 10.9	TORNILLO CHC M8X55 10.9
17	1320	KIT REP POMPE FREIN	KIT REPAIR REAR MASTER CYLINDER	KIT REP BOMBA TRAS
18	0630	KIT REPARATION ETRIER	KIT REPAIR CALIPER	KIT REPARACIÓN PINZA TRASERA
19	1295	AXE CHAPE PEDALE DE FREIN	AXEL READ BREAK ROD	AXE HORQUILLA PEDAL
20	1294	GOUPILLE CHAPPE DE FREIN	PIN READ BREAK	GOUPILLE FRENO TRASERO
21	M305	ECROU M8 NYLSTOP	HEX NUT M8 NYLSTOP	TUERCA M8 NYLSTOP
22	0655	VIS CHC M5X10	SCREW CHC M5X10	TORNILLO CHC M5X10
23	2216	ENTRETOISE PEDALE FREIN	SPACER BRAKE PEDAL	CASQUILLO PALANCA FRENO

Boite filtre - echapement / Air filter box - exhaust system / Caja filtro - escape

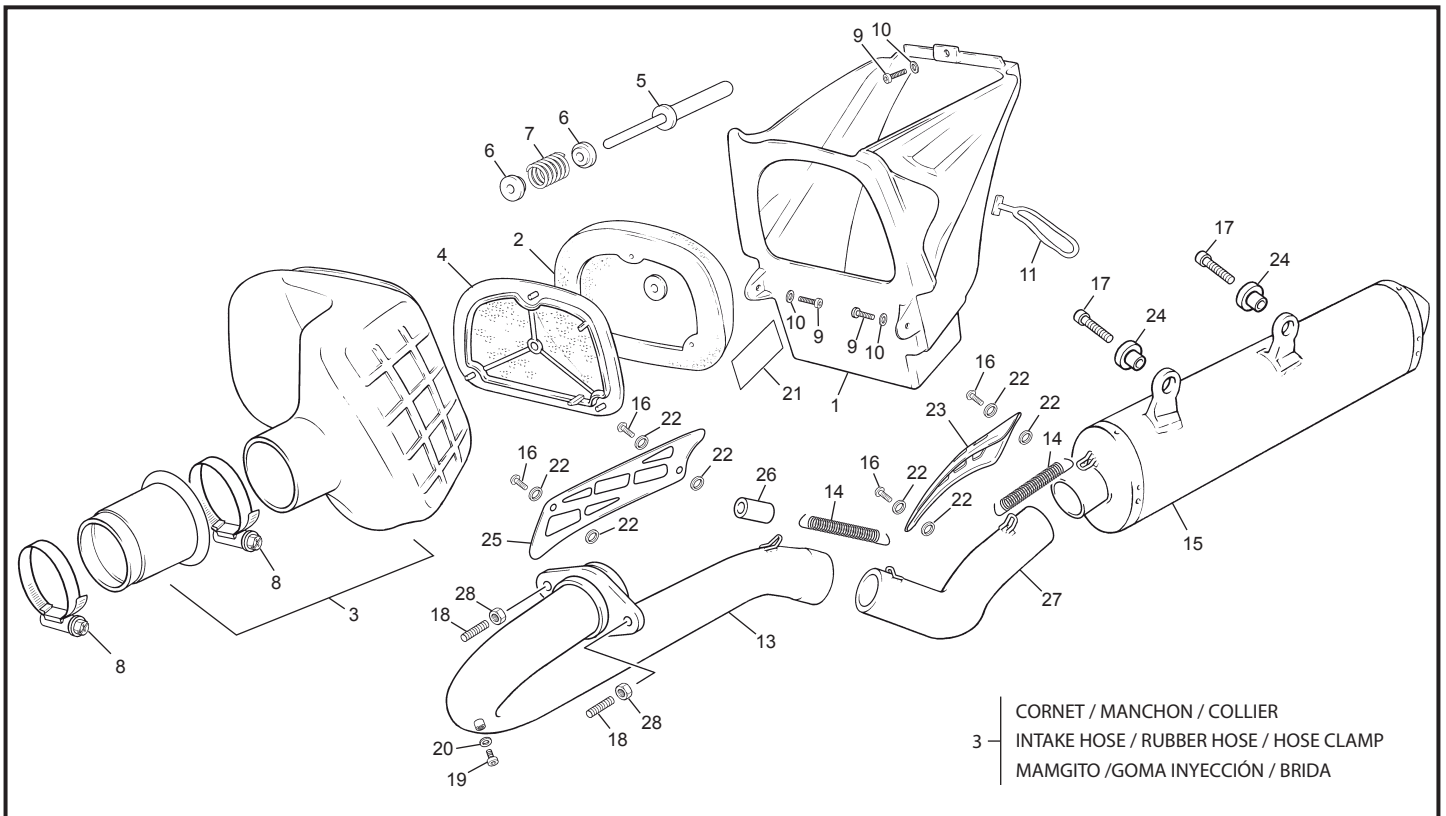

POS	SE 2.5i/3.0i F	SE 2.5i/3.0i FR	SX 2.5i F	FRANÇAIS	ENGLISH	ESPAÑOL
1	0283	0283	0283	BOITIER FILTRE AIR	AIR BOX	CAJA FILTRO
2	2028	2028	2028	MOUSSE FILTRE	FILTER ELEMENT	ESPUMA FILTRO
3	1965	1965	1965	MANCHÓN COMPLET	INTAKE HOSE ASSY	CONJUNTO TUBERA ADMISIÓN
4	2029	2029	2029	SUPPORT MOUSSE DE FILTRE	AIR FILTER RETAINER	SOPORTE ESPUMA FILTRO
5	0515	0515	0515	AXE FIXATION MOUSSE FILTRE	AIR FILTER MOUNTING BOLT	EJE EMPUJADOR ESPUMA FILTRO
6	0609	0609	0609	BUTEE RESSORT MOUSSE DE FILTRE	SPRING RETAINER	TOPE MUELLE EMPUJADOR
7	0514	0514	0514	RESSORT MOUSSE FILTRE	SPRING	MUELLE EMPUJADOR
8	0595	0595	0595	COLLIER KC060 MANCHÓN CORP INJ.	HOSE CLAMP	BRIDA TOBERA KC060 CUERPO INYEC.
9	0546	0546	0546	VIS TH EP 6X20	SREW TH EP 6X20	TORNILLO TH EP 6X20
10	M317	M317	M317	RONDELLE 6X12 04076	WASHER 6X12	ARANDELA 6 DIN 125 A
11	0306	0306	0306	CAUTCHOUC DE MAINT. DE BEQUILLE	SIDE STAND RUBBER	GOMA CABALLETE
12	0018	0018	0018	BRIDE D'ÉCHAPPEMENT	EXHAUST MANIFOLD	BRIDA ESCAPE
13	1652	1652	1652	TUBE ÉCHAPPEMENT	EXHAUST PIPE	TUBO ESCAPE
14	0271	0271	0271	RESSORT POT	EXHAUST SPRING	MUELLE ESCAPE
15	1491	-----	-----	SILENCIEUX	SILENCER	SILENCIOSO
15	-----	2105	2106	SILENCIEUX CARBONE	SILENCER CARBONE	SILENCIOSO CARBONO
16	1366	1366	1366	VIS BHC 6X8	SCREW BHC 6X8	TORNILLO BHC 6X8
17	0547	0547	0547	VIS TH EP 6 X 30	SCREW TH EP 6X30	TORNILLO TH EP 6X30
18	2065	2065	2065	GOIJON M6X30	STUD M6X30	ESPÁRRAGO M6X30
19	0557	0557	0557	BOUCHON PRISE CO2	COVER CO2 PORT	TAPÓN CO2
20	0733	0733	0733	RONDELLE AET 10	WASHER AET 10	ARANDELA AET 10
21	0700	0700	0700	ADH.TERMIQUE BOITE FILTRE	FILTER BOX STICKER	PROTECTOR TÉRMICO CAJA FILTRO
22	0746	0746	0746	RONDELLE AET 6	WASHER AET 6	ARANDELA AET 6
23	1285	1285	1285	TOLE PROTECTIA THERMIQUE	STEEL PROTECTION THERMIC	CHAPA PROTECCIÓN CALORICA
24	0274	0274	0274	SILENBLOCK SILENCIEUX	RUBBER SILENCER	GOMA SILENCIOSO
25	1375	1375	1375	TOLE PROTECTIA THERMIQUE	STEEL PROTECTION THERMIC	CHAPA PROTECCIÓN CALORICA
26	1378	1378	1378	CAUTCHOUC RESSORT POT	RUBBER SPRING EXHAUST	GOMA MUELLE ESCAPE
27	2344	2344	2344	TUBE INTERMÉDIAIRE CATALYSÉ	INTERMED. EXHAUST PIPE WITH CATALYSED	TUBO ESCAPE INTER. CON CATALIZADOR
27	-----	-----	2346	TUBE INTERMÉDIAIRE	INTERMED. EXHAUST PIPE	TUBO ESCAPE INTERMEDIO
28	2198	2198	2198	ECROU M6	NUT M6	TUERCA M6

Radiateur / Radiator / Radiador

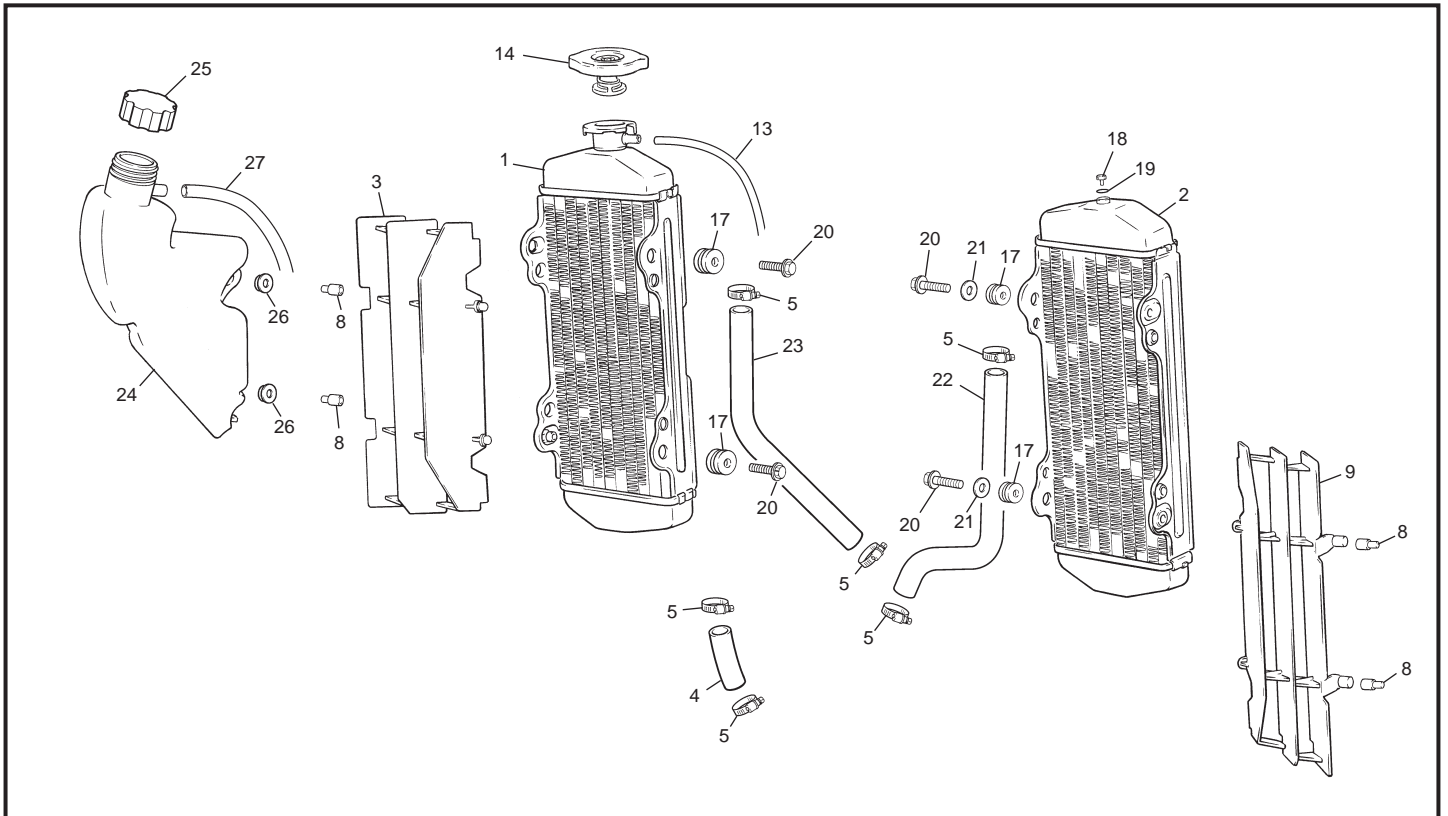

POS.	SE 2.5 / 3,0i F/R	SX 2.5i F	FRANÇAIS	ENGLISH	ESPAÑOL
1	1653	1653	RADIATEUR DROIT	RIGHT RADIATOR	RADIADOR DERECHO
2	1654	1654	RADIATEUR GAUCHE	LEFT RADIATOR	RADIADOR IZQUIERDO
3	0277	0277	GRILLE RADIATEUR D	RH RADIATOR GUARD	REJILLA RADIADOR DERECHO
4	1691	1691	DURITE RADIATEUR 90	HOSE RADIATOR 90	TUBO RADIADOR 90
5	0281	0281	COLLIER FIXATION DURITE	HOSE CLAMP	BRIDA TUBO RADIADOR
8	0498	0498	EMBOUT GRILLE RADIATEUR	RADIATOR GUARD SPACER	CASQUILLO REJILLA RADIADOR
9	0273	0273	GRILLE RADIATEUR G	LH RADIATOR GUARD	REJILLA RADIADOR IZQUIERDO
13	2144	2144	DURITE ESSENCE/RADIATEUR 5X10X515	OVERFLOW HOSE 5X10X515	TUBO GASOLINA/RADIADOR 5X10X515
14	0698	0698	BOUCHON RADIATEUR	RADIATOR CAP	TAPÓN RADIADOR
17	H059	H059	SILENTBLOCK RADIATEUR	RADIATOR INSULATOR	SILENBLOCK RADIADOR
18	0592	0592	VIS TH EP 6 X 8	SCREW TH EP 6 X 8	TORNILLO TH EP 6X8
19	0601	0601	RONDELLE ALU 6.5 X 11 X 1	WASHER ALU 6.5 X 11 X 1	ARANDELA ALU 6.5 X 11 X 1
20	0656	0656	VIS TH EP 6X16	SREW TH EP6X16	TORNILLO TH EP 6X16
21	M321	M321	RONDELLE 6 X18	WASHER 6X18	ARANDELA 6X18 DIN 9021
22	1690	1690	DURITE RADIATEUR 256	RUBBER HOSE RADIATOR 256	TUBO RADIADOR 256
23	1689	1689	DURITE RADIATEUR 305	RUBBER HOSE RADIATOR 305	TUBO RADIADOR 305
24	1940	-----	VAS EXPANSION 450 EVO	SPACER EXPANSION TANK 450 EVO	VASO EXPANSIÓN 450 EVO
25	0748	-----	BOUCHON VAS EXPANSION	EXPANSION CAP	TAPÓN VASO EXPANSIÓN
26	0565	-----	ENTRE TOISE CARROSSERIE	EXPANSION TANK STOPPER	CASQUILLO CARROSERÍA
27	1918	-----	DURITE RADIATEUR	RUBBER HOSE RADIATOR	TUBO RADIADOR

Faisceau électrique / Electrical system / Instalación eléctrica

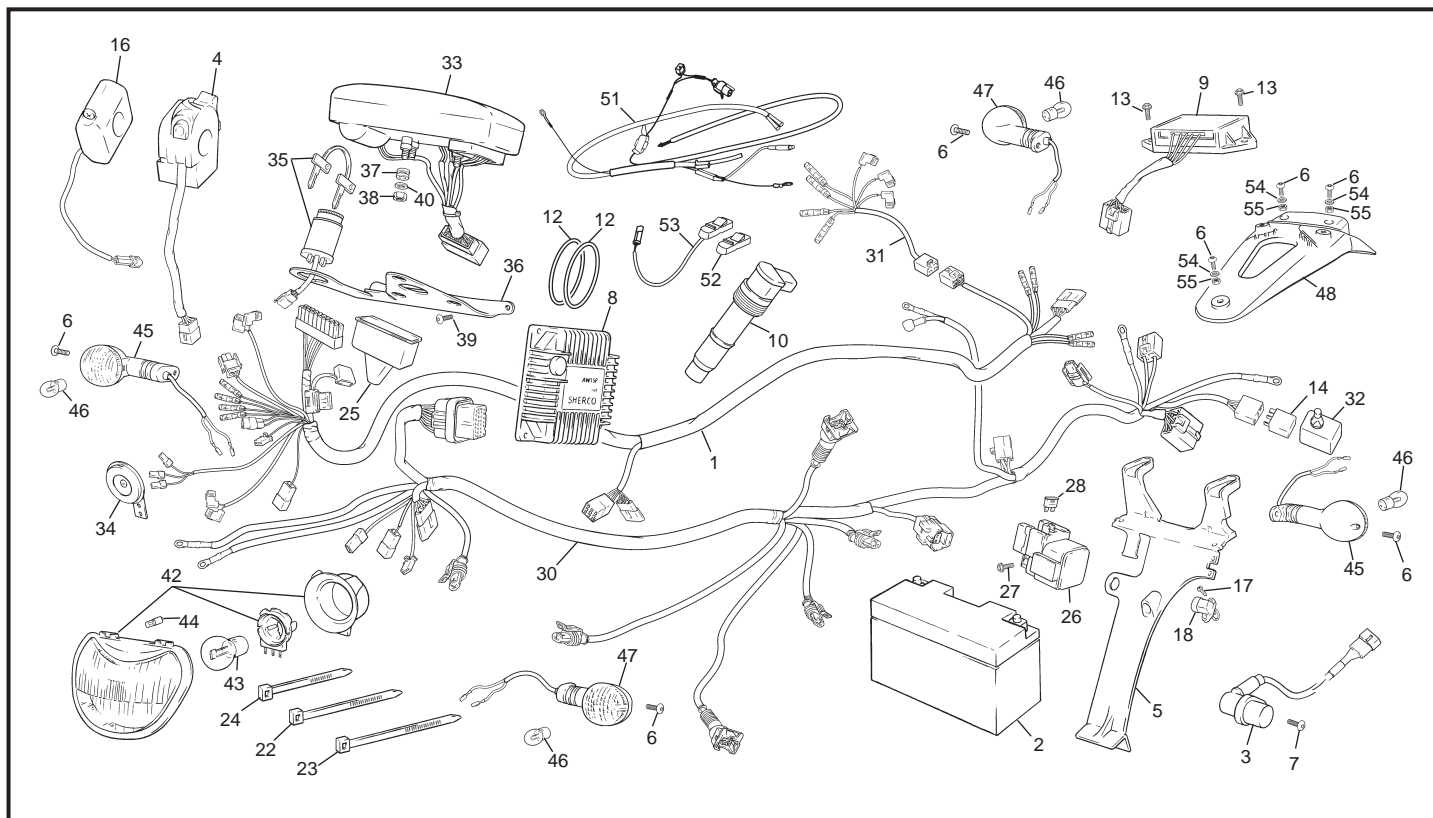

POS.	SE 2.5i F/R	SE 3.0i F/R	SX 2.5i F	FRANÇAIS	ENGLISH	ESPAÑOL
1	1754	1754	-----	FAISCEAU ELECT. GENER. ANTERIEUR EVO	FRONT HARNESS ASSEMBLY EVO	INSTALACIÓN ELÉCTRICA ANTERIOR EVO
1	1542	1542	-----	FAISCEAU ELECT. GENERAL ANTERIEUR	FRONT HARNESS ASSEMBLY	INSTALACIÓN ELÉCTRICA ANTERIOR
2	1446	1446	1446	BATTERIE 12V7AMP	BATTERY 12V7AMP	BATERÍA 12V7AMP
3	0372	0372	-----	CAPTEUR TOURS COMPTEUR KM.	SPEEDOMETER SENSOR	SENSOR VELOCIDAD
4	0413	0413	-----	COMMOGA GAUCHE	LH SWITCH ASSEMBLY	CONMUTADOR ELÉCTRICO
5	0375	0375	0375	CALE BATERIE SUPPORT COMP ELEC	BATTERY MOUNTING BRACKET	SOPORTE BATERÍA
6	M283	M283	-----	VIS BHC 6X16	SCREW BHC 6X16	TORNILLO BHC 6X16
7	0656	0656	0656	VIS THEP 6X16	SCREW THEP 6X16	TORNILLO THEP 6X16
8	1953	2334	2335	BOITIER ELECTRONIQUE	ELECTRONIC BOX	CENTRALITA ELECTRÓNICA
9	0368	0368	0368	REGULATEUR	REGULATOR	REGULADOR
10	0967	0967	0967	BOBINE CRAYON	COIL ASSY IGNITION	CTO. PIPA BUJÍA
12	1702	1702	1702	FIXATION ECU	RUBBER ECU	GOMA ECU
13	0546	0546	0546	VIS TH EP 6X20	SREW TH EP 6X20	TORNILLO THEP 6X20
14	0749	0749	0749	RELE SIEMENS A402	RELE SIEMENS A402	RELÉ SIEMENS A402
15	H252	H252	-----	AMPOULE FEU AR	TAIL LIGHT BULB	BOMBILLA LUZ TRASERA
16	0366	0366	-----	CÓMODO COMPTEUR	SPEEDOMETER CONTROL SWITCH	CONMUTADOR VELOCÍMETRO
17	0406	0406	0406	VIS CORPS THERMOSTAT	SCREW 3.5X19 DIN 7981	TORNILLO 3.5 X 19 DIN 7981 C CRUZ
18	0399	0399	0399	CAPTEUR AIR	AIR SENSOR	SENSOR AIRE
19	0650	0650	0650	VIS CHC M3 X 25	SCREWCHC M3X25	TORNILLO M3 X 25 DIN 912
20	0653	0653	0653	ECROU M3 NYLSTOP	NUT NYLSTOP M3	TUERCA M3 DIN 985
21	0648	0648	0648	RONDELLE 3	WASHER 3	ARANDELA 3 DIN 125
22	M330	M330	M330	COLLIER RISLAN 178X4.8	ZIP TIE 178X4.8	ABRAZADERA 178X4.8
23	C441	C441	C441	COLLIER RYSLAN 208X4.8	ZIP TIE 280X4.8	ABRAZADERA 280X4.8
24	M331	M331	M331	COLLIER RISLAN 100X2.5	ZIP TIE 100X2.5	ABRAZADERA 100X2.5
25	0671	0671	-----	CAUTCHOUC FAISCEAU	RUBBER BOOT	CAPUCHÓN INSTALACIÓN ELÉCTRICA
26	0367	0367	0367	RELÉ DEMARREUR	STARTER RELAY	RELÉ DEMARRER
27	0592	0592	0592	VIS TH EP 6 X 8	SCREW TH EP 6 X 8	TORNILLO THEP 6X8
28	0661	0661	0661	FUSIBLE 30 A LITLIFUSE	FUSE 30A	FUSIBLE 30 A LITLIFUSE
29	0657	0657	0657	VIS M4 X 45 CRUCIFORME	SCREW M4 X 45	TORNILLO M4 X 45 CRUCIFO. DIN 7881
30	1655	1655	-----	FAISCEAU ELECTR. INJECT.	ELECTRIC SYSTEM INJECTION	INSTAL. ELÉCTRICA INYECCIÓN
30	2147	2147	2147	FAISCEAU ELECTR. INJECT. EVO	ELECTRIC SYSTEM INJECTION EVO	INSTAL. ELÉCTRICA INYECCIÓN EVO
31	0666	0666	0666	FAISCEAU ELECTRIQUE GEN. POST.	BACK ELECTRICAL CABLE SIST.	INSTALACIÓN ELÉCTRICA POST.
32	1291	1291	1291	SUPPORT RELAIS	HOLDER RELAY	SOPORTE RELÉ
33	0365	0365	-----	COMPTEUR DE VITESSE	SPEEDOMETER	VELOCÍMETRO

Roue avant / Front wheel / Rueda delantera

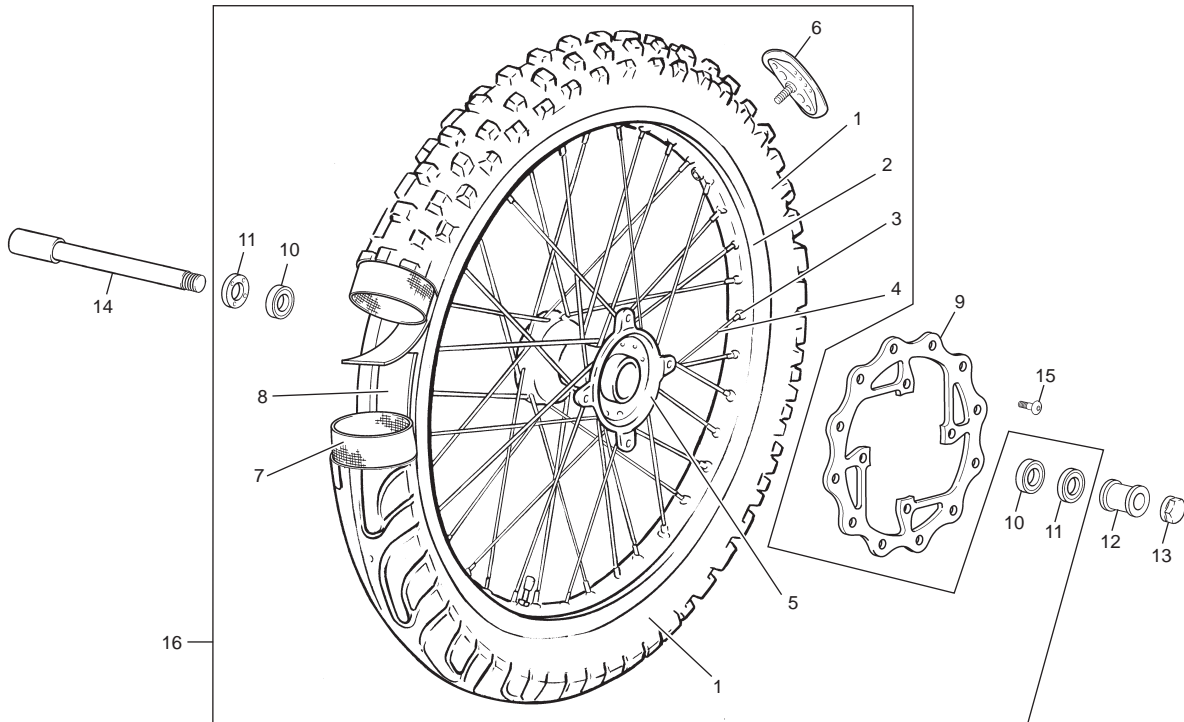

POS.	SE 2.5 / 3,0i F	SE/SX 2.5 / 3,0i FR	FRANÇAIS	ENGLISH	ESPAÑOL
1	0312	0312	PNEU AVANT 90X90/21	FRONT TIRE 90X90X21	NEUMÁTICO DEL 90X90/21
2	1203	1203	JANTE AV 1,6 X 21 NOIR	FRONT RIM 1,6 X 21 BLACK	LLANTA DEL 1,6 X 21 NEGRO
3	0714	0714	ECROU RAYÓN 3,5 (36)	SPOKE NIPPLE 3,5 (36)	TUERCA RADIO 3,5 (36)
4	0710	0710	RAYON AVANT 3,5X242 (36)END	SPOKE 3,5X242 (36)	RADIO DELANTERO 3,5X242 (36) END
5	0310	0310	MOYEU COMPLET AV	HUB	BUJE CPL
6	0311	0311	GRIPSTER1.6	RIM LOCK	AGARRACUBERTIAS
7	0313	0313	CHAMBRE AIR21	INNER TUBE 21	CAMARA 21
8	0314	0314	FOND JANTE AV 21	RIM BAND 21	FONDO LLANTAS 21
9	1937	1937	DISQUE FREIN AV	FRONT ROTOR	DISCO FRENO DEL
10	R049	R049	ROULEMENT DE NOYEU 6004 2RS	HUB BEARING 6004 2RS	RODAMIENTO BUJE 6004 2RS
11	0706	0706	JOINT A LEVRES 25X42X7	OIL SEAL 25X42X7	RETÉN 25X42X7
12	0318	1434	ENTRETOISE ROUE AVANT	FRONT WHEEL SPACER	CASQUILLO RUEDA DEL.
13	0316	0316	ECROU ROUE AVANT	FRONT AXLE NUT	TUERCA RUEDA DEL.
14	0315	0315	AXE DE ROUE AVANT	FRONT WHEEL AXLE	EJE RUEDA DEL.
15	0452	0452	VIS SPECIALE DISQUE	ROTOR BOLTS	TORNILLO ESPECIAL DISCO FRENO
16	1189	1189	ROUE AVANT SANS DISQUE NOIRE	FRONT WHEEL WITHOUT DISC BLACK	RUEDA DEL. SIN DISCO NEGRA

Roue arriere / Rear wheel / Rueda trasera

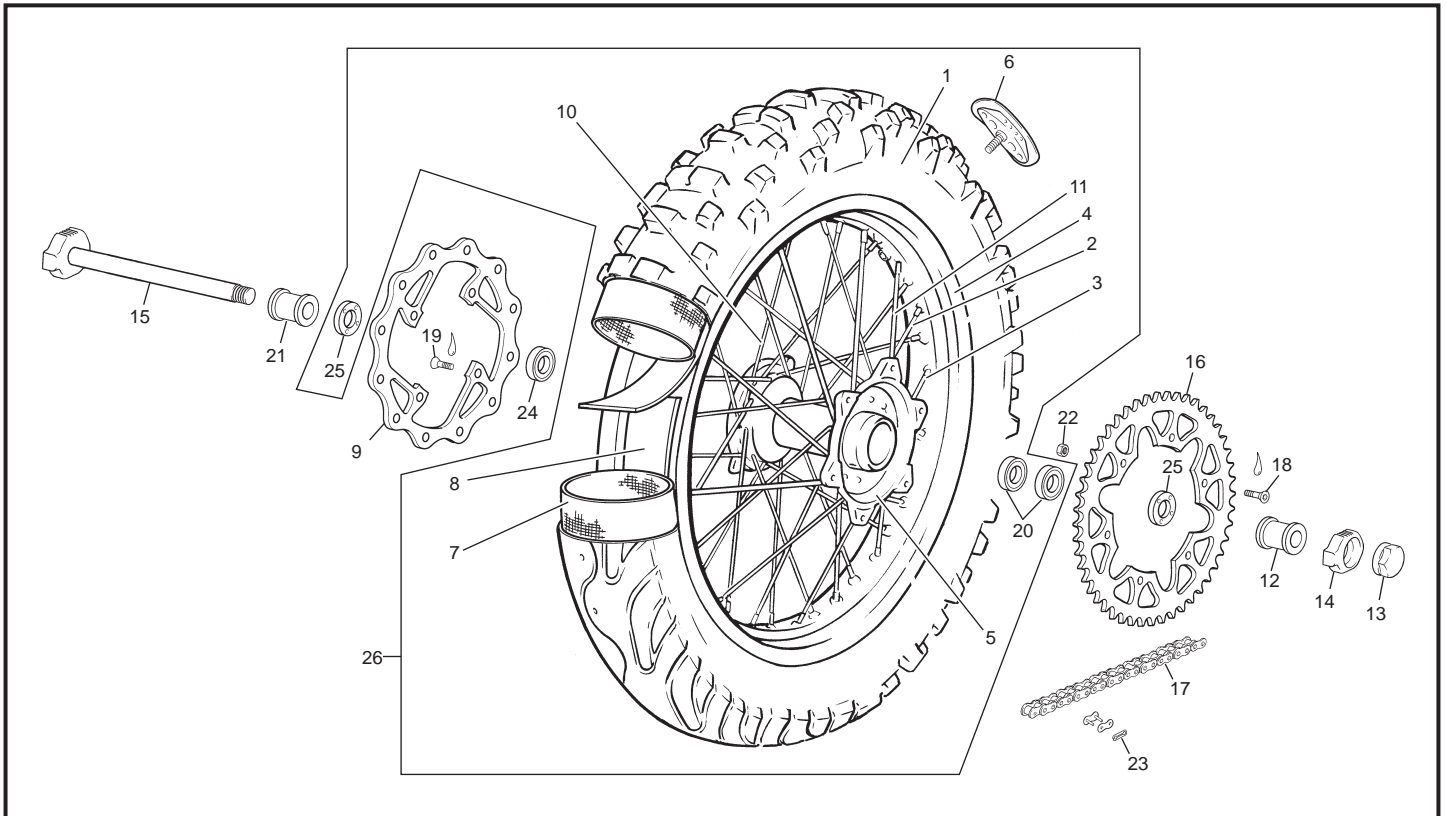

POS.	SE 2.5 / 3,0i F/R	SX 2.5i F	FRANÇAIS	ENGLISH	ESPAÑOL
1	0323	-----	PNEU AR 140X18	REAR TIRE 140X18	NEUMÁTICO TRAS 140X18
1	-----	1706	PNEU AR MX	REAR TIRE MX	NEUMÁTICO TRAS MX
2	1204	-----	JANTE AR 2.15X18 NOIRE	REAR RIM 2.15 X 18 BLACK	LLANTA TRAS 2.15 X 18 NEGRA
3	0715	-----	ECROU RAYON 4 (36)	SPOKE NIPPLE 4 (36)	TUERCA RADIO 4 (36)
4	0711	-----	RAYON POST. 4X200 (9) END	SPOKE 4 X 200 (9)	RADIO TRAS 4X200 (9) END
5	0823	0823	MOYEU COMPLET AR	REAR HUB	BUJE TRAS.
6	0322	0322	GRIPSTER 2.15" AR	REAR RIM LOCK	AGARRACUBIERTAS TRAS.
7	0324	-----	CHAMBRE AIR 18"	REAR INNER TUBE 18	CAMARA 18
7	-----	1707	CHAMBRE AIR 19"	REAR INNER TUBE 19	CAMARA 19
8	0325	-----	FOND DE JANTE 18"	REAR RIM BAND 18	FONDO LLANTA 18
8	-----	1708	FOND DE JANTE 19"	REAR RIM BAND 19	FONDO LLANTA 19
9	1938	1938	DISQUE FREIN AR	REAR BRAKE ROTOR	DISCO FRENO TRAS.
10	0713	-----	RAYON POST. 4X204 (18)	SPOKE 4X204 (18)	RADIO TRAS. 4X204 (18) END
11	0712	-----	RAYON POST. 4X206 (9) END	SPOKE 4X206 (9)	RADIO TRAS 4X206 (9) END
12	0343	0343	ENTRETOISE ROUE AR GAUCHE	LH REAR WHEEL SPACER	CASQUILLO RUEDA TRAS. IZQ.
13	0329	0329	ECROU ROUE AR	REAR AXLE NUT	TUERCA RUEDA TRAS.
14	0327	0327	TENSEUR CHAINE DROIT	RH CHAIN TENSIONER	SENSOR CADENA DER.
15	0326	0326	AXE DE ROUE AR	REAR AXLE	EJE RUEDA TRAS.
17	0333	-----	CHAÎNE 112M	CHAIN 112M	CADENA 112M
17	-----	2348	CHAÎNE 114M	CHAIN 114M	CADENA 114M
18	0454	0454	VIS SPECIALE COURONNE	SPROCKET BOLTS	TORNILLO ESPECIAL CORONA
19	0452	0452	VIS SPECIALE DISQUE	BRAKE ROTOR BOLTS	TORNILLO ESPECIAL DISCO FRENO
20	0716	0716	ROULEMENT 6005 2RS1 25X47X12	BEARING 6005 2RS1 25X47X12	RODAMIENTO 6005 2RS1 25X47X12
21	0344	0344	ENTRETOISE ROUE AR DROITE	RH REAR WHEEL SPACER	CASQUILLO RUEDA TRAS. DER.
22	M305	M305	ECROU NYLSTOP M8 0368.10	NUTNYLSTOP M8	TUERCA NYLSTOP M8
23	R473	R473	ATACHE RAPIDE	CONNECTING LINK	ENGANCHE
25	0718	0718	JOINT LEVER 32X42X7	OIL SEAL 32X42X7	RETÉN 32X42X7
26	1190	-----	ROUE ARR. SANS DISC/COURONE NOIRE	REAR WHEEL WITH. DISK/SPROKET BLACK	RUEDA TRAS. SIN DISCO/CORONA NEG.
26	-----	1705	ROUE ARR. MX	REAR WHEEL MX	RUEDA TRAS. MX

Guidon / Handlebar / Manillar

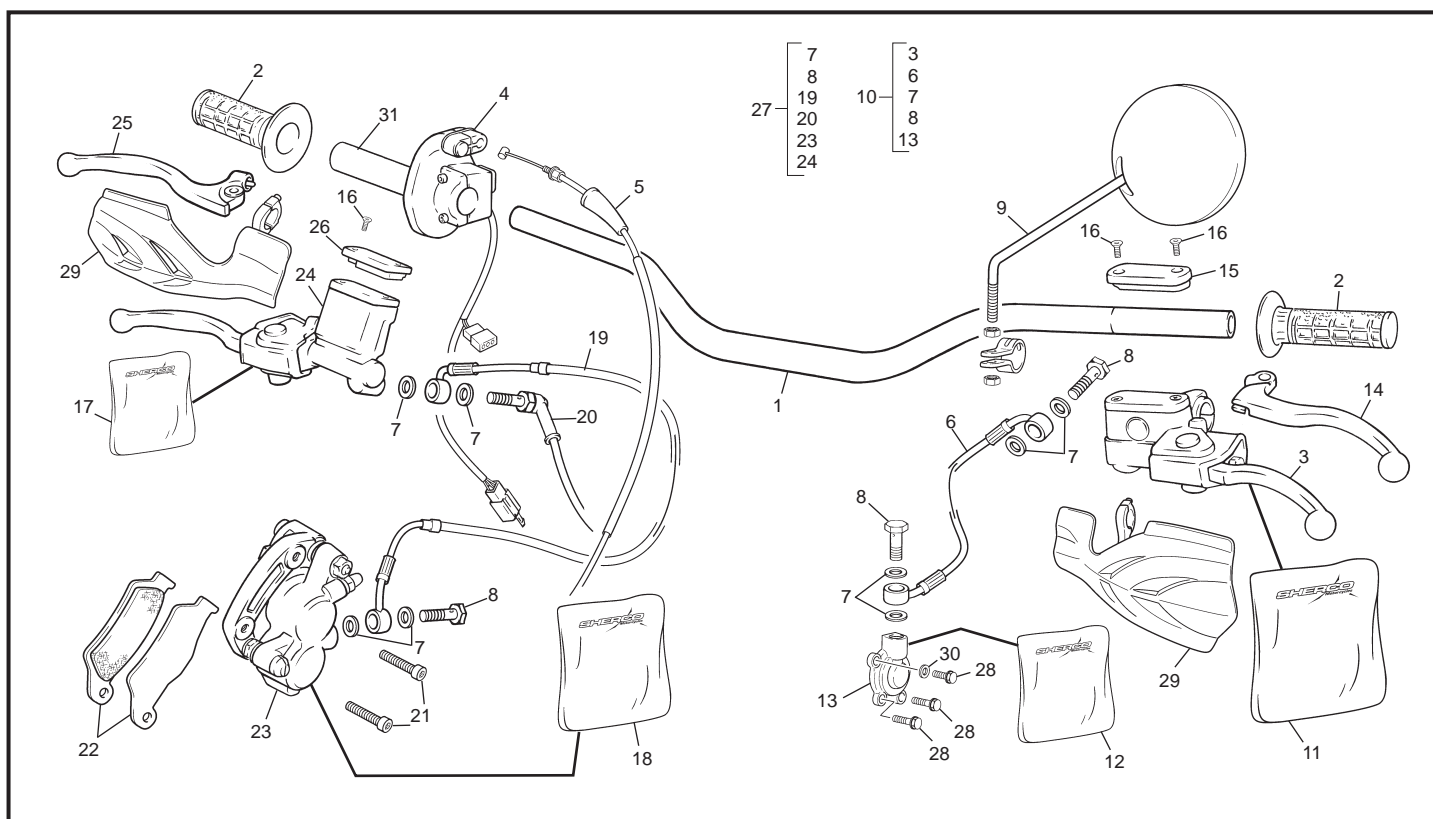

POS.	SE 2.5/3,0i F	SE 2.5/3,0i FR - SX 2i	FRANÇAIS	ENGLISH	ESPAÑOL
1	1225	1225	GUIDON NOIR	HANDLEBAR BLACK	MANILLAR NEGRO
2	1662	1662	GROUPE POIGNEES SHERCO PAIRE	GRIP SET - SHERCO	JUEGO EMPUÑADURAS SHERCO
3	0612	0612	POMPE EMB CPL	CLUTCH MASTER CYLINDER ASSEMBLY	CTO. BOMBA EMBRAGUE
4	1280	1280	COMMANDE DE GAZ	THROTTLE GAS	MANDO GAS
5	1979	1979	CABLE DE GAZ	THROTTLE CABLE	CABLE DE GAS
6	3289	3289	DURITE EMBRAYAGE	CLUTCH HOSE ASSEMBLY	LATIGUILLO EMBRAGUE
7	R074	R074	RONDELLE BANJO	ALUMINIUM SEAL	ARANDELA BANJO
8	R059	R059	VIS RACCORD M10X21	BANJO BOLT	TORNILLO RACORD M10X21
9	S232	S232	RETROVISEUR	MIRROR	RETROVISOR
10	1676	1676	GROUPE EMBRAYAGE COMPLET	COMPLETE CLUTCH HYDRAULIC SYSTEM	CTO. EMBRAGUE
11	0616	0616	KIT REPARATION POMPE EMBRAYAGE	CLUTCH MASTER CYLINDER REPAIR KIT	KIT REPARACIÓN BOMBA EMBRAGUE
12	1954	1954	KIT REPARATION PISTÓN EMBRAYAGE	CLUTCH SLAVE CYLINDER REPAIR KIT	KIT REPARACIÓN PISTÓN EMBRAGUE
13	0979	0979	RECEPTEUR EMB CPL	CLUTCH SLAVE CYLINDER	RECEPTOR EMBRAGUE CPL
14	0615	0615	LEVIER EMBRAYAGE	CLUTCH LEVER	MANETA
15	0644	-----	COUVERCLE POMPE EMB	CLUTCH RESERVOIR COVER	TAPETA BOMBA EMB
15	-----	2315	COUVERCLE POMPE EMB ALU	CLUTCH RESERVOIR COVER ALLOY	TAPETA BOMBA EMB ALUMINIO
16	0647	0647	VIS COUVERCLE POMPE	SCREW	TORNILLO TAPETA BOMBA
17	0622	2349	KIT REPARATION POMPE FREIN	BRAKE MASTER CYLINDER REPAIR KIT	KIT REPARACIÓN BOMBA DE FRENO
18	0623	0623	KIT REPARATION ETRIER AV	FRONT CALIPER REPAIR KIT	KIT REPARACIÓN PINZA DEL.
19	1281	2350	DURITE FREIN AV TEFLON	FRONT BRAKE HOSE 450 TEFLON	LATIGUILLO FRENO DELANTERO TEFLÓN
20	0625	0625	INTERUPTEUR FREIN	BRAKE LIGHT SWITCH	INTERRUPTOR FRENO
21	C414	C414	VIS CHC M8X35	SCREW CHC M8X35	TORNILLO ULS M8X35
22	1679	1679	PLAQUETTES FREIN AV PAIRE	FRONT BRAKE PADS (PAIR)	JUEGO PASTILLAS FRENO DEL.
23	0619	2352	ETRIER FREIN AVANT450	FRONT CALIPER ASSY	PINZA FRENO DELANTERO
24	0618	2351	POMPE FREIN AV CPL	FRONT BRAKE MASTER CYLINDER ASSY	BOMBA FRENO DELANTERO
25	0621	2353	LEVIER FREIN AVANT SEÛL	FRONT BRAKE LEVER	MANETA FRENO
26	0646	-----	COUVERCLE POMPE FREIN AV	BRAKE RESERVOIR COVER	TAPETA BOMBA FRENO DELANTERO
26	-----	2314	COUVERCLE POMPE FREIN AV ALU.	BRAKE RESERVOIR COVER ALLOY	TAPETA BOMBA FRENO DEL. ALUMINIO
27	1288	2305	GROUPE FREIN AVANT COMPLET	COMP. FRONT BRAKE HYDR. SYSTEM	CTO. FRENO DEL.
28	0656	0656	VIS THEP M6X16	SCREW THEP M6X16	TORNILLO THEP M6X16
29	-----	1149	PARE MAINS NOIRS JEU	HAND GUARD BLACK SET	PARA MANO NEGRO JUEGO
30	M317	M317	RONDELLE M6	WASHER M6	ARANDELA M6
31	3106	3106	POIGNEE TOURNANTE RECHANGE ENDURO	REVOLVING HANDLE SPARE ENDURO	CAÑA GAS ENCURO DE RECAMBIO

Plastiques / Plastics / Plásticos

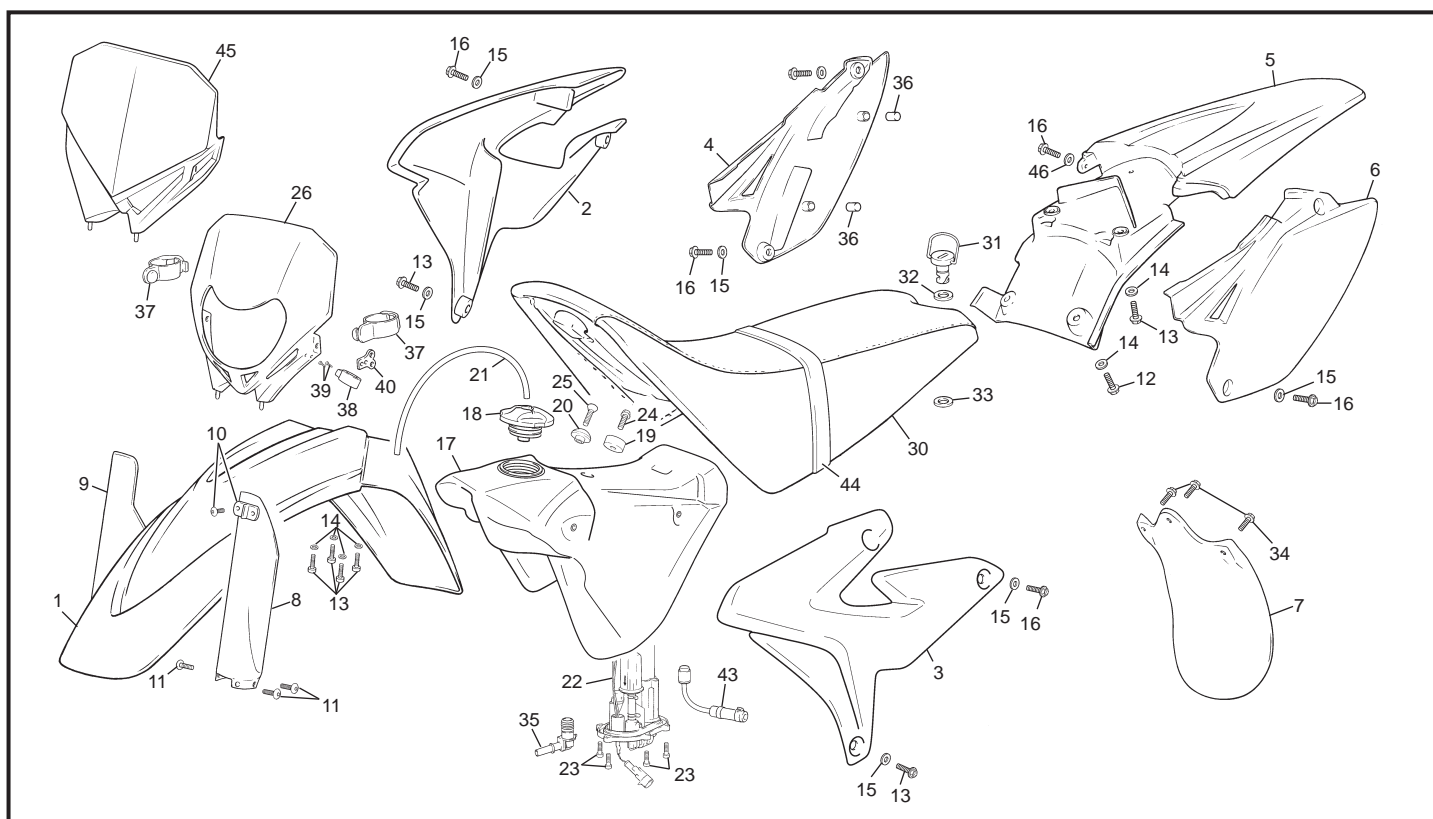

POS.	SE 2.5i / 3.0i FR	SX 2.5i F	FRANÇAIS	ENGLISH	ESPAÑOL
1	0248	0248	PARE BOUE AVANT BLEUE	FRONT FENDER BLUE	GUARDABARROS DEL AZUL
2	1928	1928	OUÏE DROITE BLEUE	RH RADIATOR SIDE PANEL BLUE	PLACA RADIADOR DER AZUL
3	1929	1929	OUÏE GAUCHE BLEUE	LH RADIATOR SIDE PANEL BLUE	PLACA RADIADOR IZQ AZUL
4	1515	1515	PLAQUE LATERAL D BLANC	RH NUMBER PLATE WHITE	PLACA NO DER. BLANCO
5	1513	1513	PARE BOUE ARRIERE BLANC	BACK MUDGUARD WHITE	GUARDABARROS TRA. BLANCO
6	1514	1514	PLAQUE LATERAL G BLANC	LH NUMBER PLATE WHITE	PLACA NO IZQ. BLANCO
7	0288	0288	BAVETTE DE FILTRE	FILTER GUARD	GUARDABARROS FILTRO
8	0356	0356	PROTECTEUR FOURCHE GA	LEFT FORK PROTECTOR	PROTECTOR HORQUILLA IZQ.
9	0355	0355	PROTECTEUR FOURCHE DR	RIGHT FORK PROTECTOR	PROTECTOR HORQUILLA DER.
10	0491	0491	GROUPE SUPPORT DURITE AV	FRONT BRACK HOSE HOLDER	CONJ. SOP. LATIGUILLO FRENO DEL.
11	0070	0070	VIS SPECIALE PROTECTEUR FOURCHE	FORK PROTECTOR BOLT	TORNILLO ESPECIAL PROT. HORQUILLA
12	0575	0575	VIS AUTO FIL 4.8X9.5LONG	SCREW AUTO TREADING 4.8X9.5 L	TORNILLO AUTO ROSCANTE 4.8X9.5 L
13	0546	0546	VIS TH EP 6X20	SREW TH EP 6 X 20	TORNILLO THEP 6X20
14	M321	M321	RONDELLE 6 X18X1.5	WASHER 6X18	ARANDELA 6X18 DIN 9021
15	0565	0565	ENTRETOISE INOX CARROSSERIE	SPACER	CASQUILLO INOX CARROCIERÍA
16	0656	0656	VIS THEP 6X16	SREWTHEP6X16	TORNILLO THEP 6X16
17	1949	1949	RESERVOIR ESSENCE	FUEL TANK	DEPÓSITO
18	H398	H398	BOUCHON ESSENCE	FUEL TANK CAP	TAPÓN GASOLINA
19	0238	0238	BUTEE PLASTIQUE RESERVOIR	RUBBER TANK HOLDER	TOPE GOMA DEPÓSITO
20	0497	0497	FIXATION SELLE RESERVOIR	SPACER SEAT /TANK	CASQUILLO SILLÍN DEPÓSITO
21	0252	0252	DURITE MISE A L'AIR BOUCHON ESSEN.	FUEL LINE	TUBO RESPIRADERO
22	0402	0402	POMPE INJECTION	FUEL INJECTION PUMP	BOMBA INYECCIÓN
22	1683	-----	POMPE INJECTION EVO (se monte avec faisceau ref. 2147)	FUEL INJECTION PUMP EVO (mount only with electrical harness ref. 2147)	BOMBA INYECCIÓN EVO (se monta únicamente con la inst. eléctrica ref. 2147)
23	M250	M250	VIS CHC 5X16 1093	SCREW CHC 5X16	TORNILLO 5X16 CHC
24	0546	0546	VIS TH EP 6X20	SREW TH EP 6X20	TORNILLO THEP 6X20
25	0652	0652	VIS FHC M6X25	SCREW FHC M6X25	TORNILLO AVELL M6 X 25 DIN 7991
26	S360	S360	PLAQUE PHARE NOIRE	FRONT LIGHT BLACK	PLACA FARO NEGRA
30	1927	1927	SELLE	SEAT	SILLÍN
31	0530	0530	DZUS DE SELLE	DZUS FASTENER	CIERRE SILLÍN
32	0532	0532	RONDELLE PLASTIQUE DZUS	WASHER	ARANDELA PLÁSTICO DZUS
33	0533	0533	RONDELLE VEROUILLAGE DZUS	DZUS CLIP	ARANDELA VEROUILLAGE DZUS
34	1274	1274	VIS TOLE FIL 4.2X16	SCREW AUTO TREADING 4.2X16	TORNILLO AUTORROSCANTE 4.2X16
35	0805	0805	CARTOUCHE COUDE POMPE	PETROL BOMB PIPETTE PART	PIPETA BOMBA GASOLINA RECAMBIO

Plastiques / Plastics / Plásticos

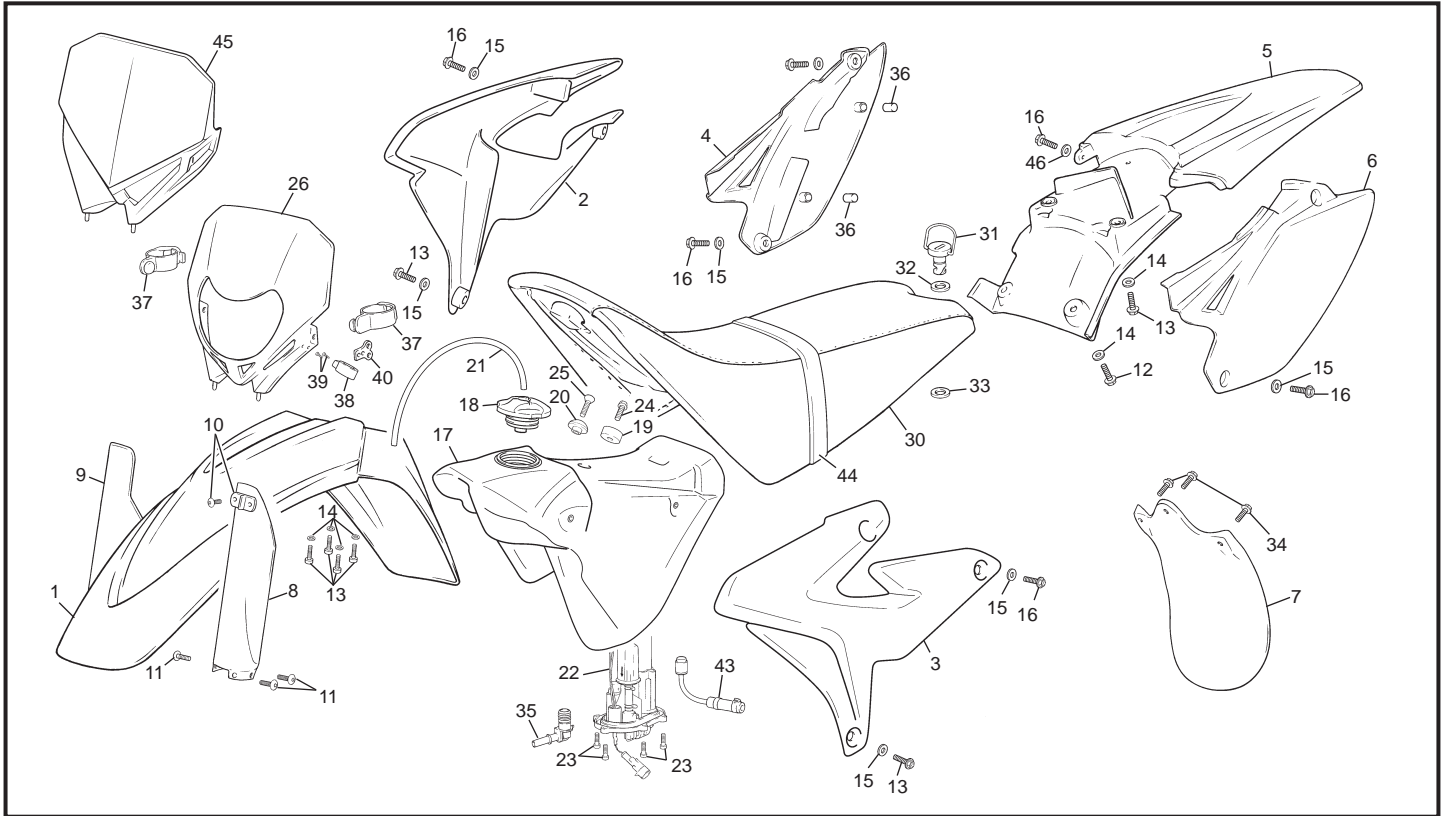

POS.	SE 2.5i / 3.0i FR	SX 2.5i F	FRANÇAIS	ENGLISH	ESPAÑOL
36	0495	0495	BUOCHON	CAP	TAPÓN
37	H050	H050	ELASTIC PLAQUE PHARE	HEADLIGHT RUBBER MOUNT	ELÁSTICO PLACA FARO
38	0363	0363	GUIDE DURITE	FRONT BRAKE LINE CLIP	GUÍA LATIGUILLO
39	M336	M336	VIS TOLE 2.9X9.5	SCREW TOLE 2.9X9.5	TORNILLO CHAPA 2.9X9.5
40	1494	1494	SUPPORT GUIDE DURITE	BRAKE HOSE SUPPORT	SOPORTE GUÍA LATIGUILLO
43	0251	0251	DURITE ALIMENTATION INJ.	HOSE INJECTION	TUBO GASOLINA INYECCIÓN
44	0793	-----	SANGLE HOM. SEWE	STRAPP SEAT HOMOL	CORREA HOMOLOGACIÓN
45	-----	S370	PLAQUE N° AVANT NOIRE	FRONT NUMBER PLATE BLACK	PLACA NÚMERO DELANTERA NEGRA
46	2085	2085	ENTRETOISE PARE BOUE	SPACER MUD GUARD	CASQUILLO GUARDABARRO

Adhesif / Sticker / Adhesivo

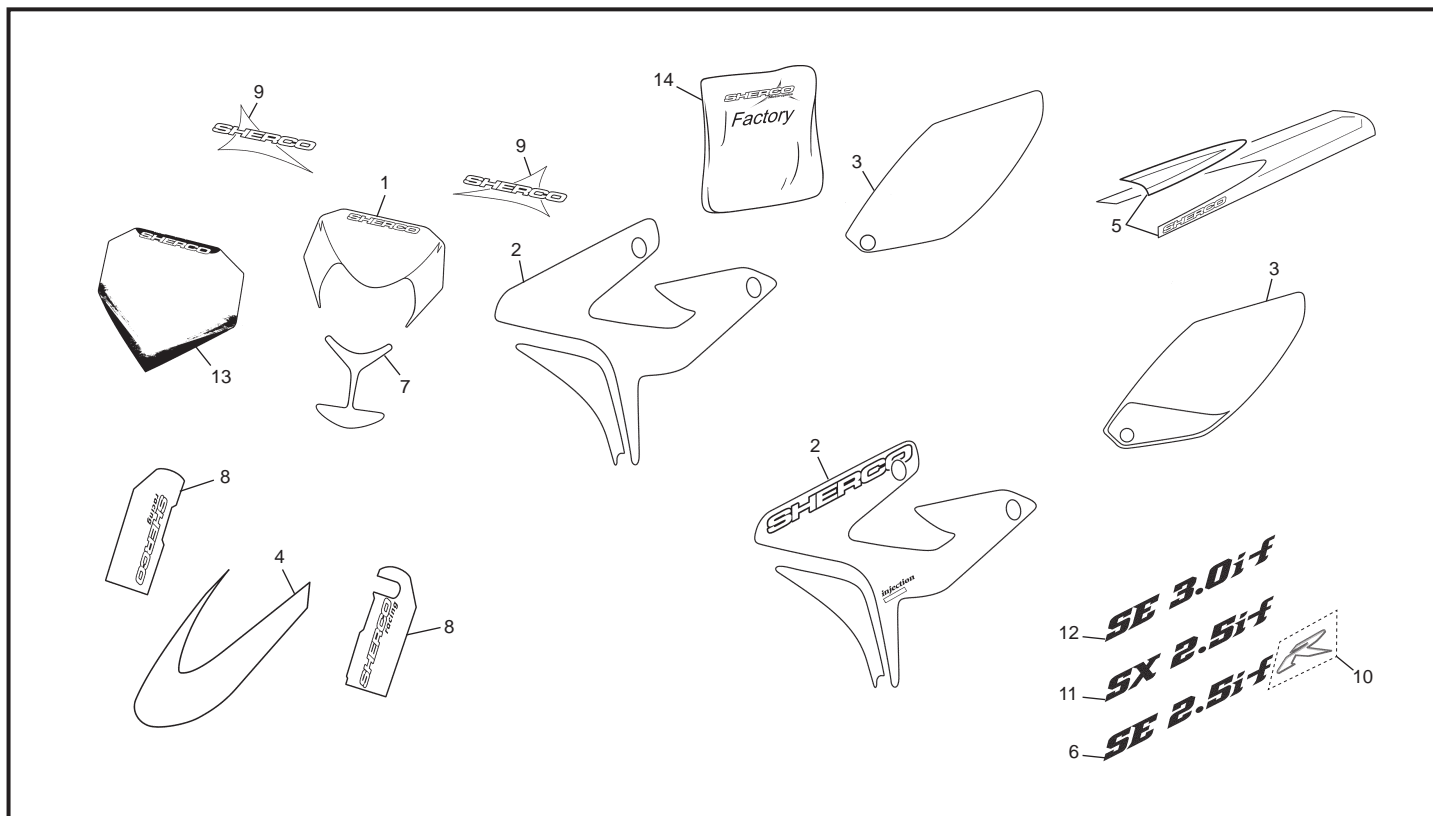

POS.	SE/SX 2.5 / 3,0i F/R	FRANÇAIS	ENGLISH	ESPAÑOL
1	2291	ADH. PLAQUE PHARE BLANC	STICKERS FRONT LIGHT WHITE	ADH. PLACA FARO BLANCO
2	2289	ADH. OUIE JEU	RADIATOR GUARD STICKERS (PAIR)	ADH. TAPA RADIADOR JUEGO
3	2290	ADH. PLAQUE NUM. JEU BLANC	SIDE NUMBER STICKERS (PAIR) WHITE	ADH. PLACA N°. JUEGO BLANCO
4	2293	ADH. PARE BOUE AVANT	STCKER FRONT MUDGARD	ADH. GUARDABARROS DELANTERO
5	2295	ADH. PARE BOUE ARRIERE	STICKER PEAR MUDGARD	ADH. GUARDABARROS TRASERO
6	2059	ADH. SE 2.5i-F	STICKER SE 2.5i-F	ADH. SE 2.5i-F
7	2296	ADH. PHARE	STICKER FRONT LIGHT	ADH. FARO
8	2292	ADH. FOURCHE	STICKER FORK	ADHESIVO HORQUILLA
9	2064	ADH. PARE MAINS JEU	STICKER HAND GUARD SET	ADHESIVO PARA MANDO JUEGO
10	2354	ADH. "R" RACING 2010	STICKER "R" RACING 2010	ADHESIVO "R" RACING 2010
11	2155	ADH. SX 2.5i F	STICKER SX 2.5i F	ADHESIVO SX 2.5i F
12	2297	ADH. SE 3.0i F	STICKER SE 3.0i F	ADHESIVO SE 3.0i F
13	2154	ADH. PLAQUE MX	STICKER PLATE N° MX	ADHESIVO PLACA N° MX
14	2964	KIT ADH. END 10 FACTORY	KIT STICKER END 2010 FACTORY	KIT ADESIVO END 2010 FACTORY

Selecteur / Gear selector group / Selector cambio

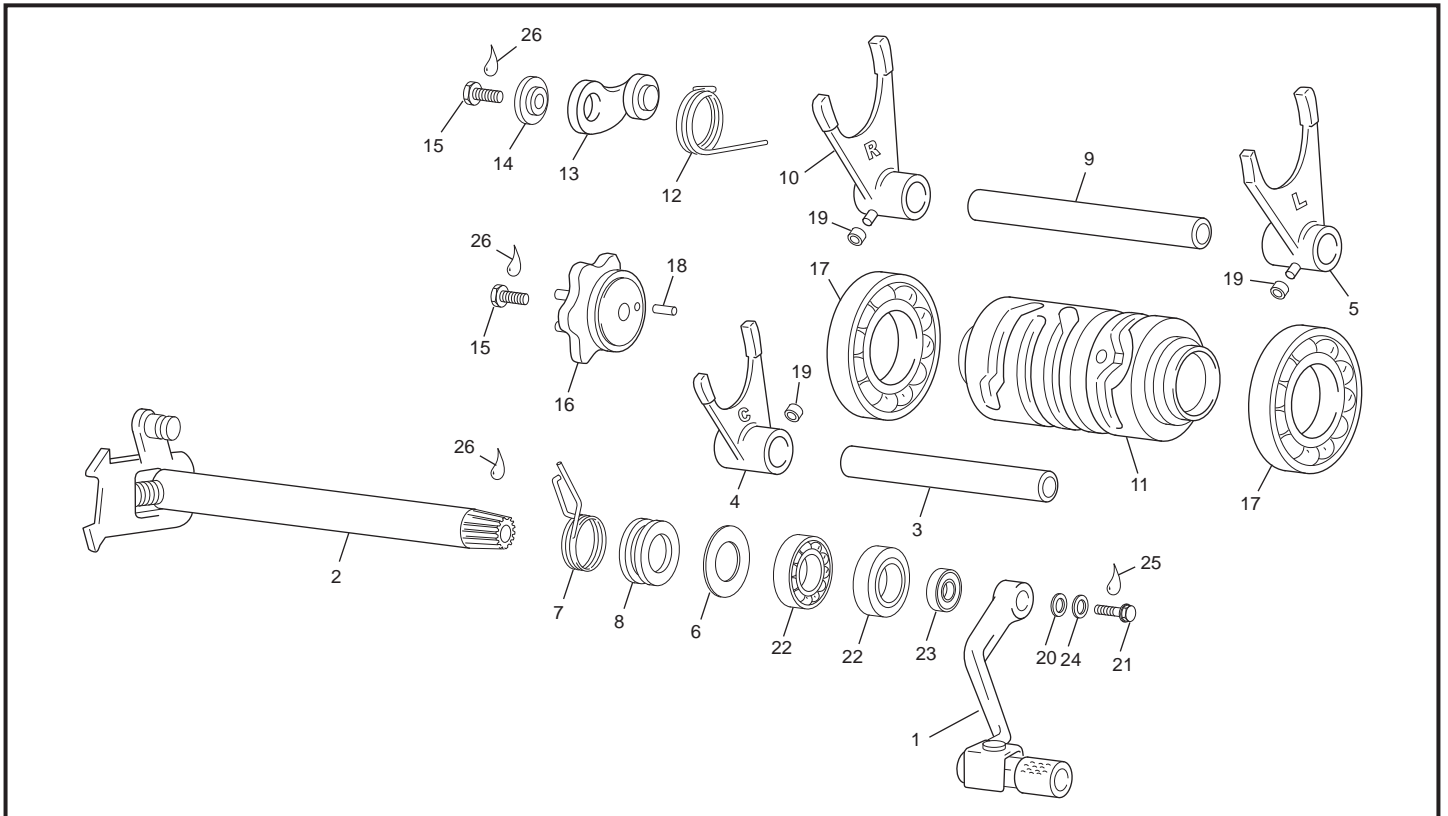

POS.	SE/SX 2.5 / 3,0i F/R	FRANÇAIS	ENGLISH	ESPAÑOL
1	0205	LEVIER DE SELECTEUR ALU	SHIFT LEVER ASSY	PALANCA CAMBIO
2	1025	ARBRE SELECTEUR CPL	SHIFT SHAFT WITH PAWL ASSY	ÁRBOL SELECTOR
3	1019	AXE DE FOURCHETTE 90	FORK AXLE 90	EJE HORQUILLA 90
4	1014	FOURCHETTE 5/6	FORK 5/6	HORQUILLA 5/6
5	1016	FOURCHETTE 2/4	FORK 2/4	HORQUILLA 2/4
6	0529	RONDELLE 14X28X1	RONDELLE 14X28X1	ARANDELA 14X28X1
7	0208	RESSORT RAPPEL SELECTEUR	SPRING SHIFT LEVER	MUELLE SELECTOR
8	0209	DOUILLE RESSORT SELECTEUR	SPACER SPRING	CASQUILLO MUELLE SELECTOR
9	1018	AXE DE FOURCHETTE 100	FORK AXLE	EJE HORQUILLA 100
10	1017	FOURCHETTE 1/3	FORK 1/3	HORQUILLA 1/3
11	1013	TAMBOUR SELECTION	SELECTOR DRUM	DESMODRÓNICO SELECTOR
12	1022	RESSORT RAPPEL VEROUILLAGE	INDEX SPRING	MUELLE BOOMERANG
13	1020	LEVIER DE VERROUILLAGE COMP.	INDEX LEVER ASSY	PALANCA CIERRE SELECTOR
14	0215	ENTRETOISE DE VERROUILLAGE	SPACER	CASQUILLO GUÍA LEVA
15	0656	VIS TH EP M6X16	SCREW M6X16	TORNILLO M6X16
16	1023	ETOILE DE SELECTION	INDEX SHIM	ESTRELLA SELECTOR
17	0868	ROULEMENT 6905	BEARING 6905	RODAMIENTO 6905
18	0101	AIGUILLE 3X11.8	NEEDLE 3X11.8	AGUJAS 3X15
19	1015	ROULEAU	ROLL	RODILLO
20	0649	RONDELLE 6X16X3	WASHER 6X16X3	ARANDELA 6X16X3
21	0546	VIS TH EP 6X20	SCREW TH EP 6X20	TORNILLO TH EP 6X20
22	0527	DOUILLES A AIGUILLES HK 14X20X2	BEARING 14X20X2	RODAMIENTO 14X20X2
23	0660	JOINT 14X24X7	SEAL 14X24X7	RETÉN 14X24X7
24	0746	RONDELLE RESSORT TYPE 56	LOCKING DISC SPRING 56	ARANDELA DE SEGURIDAD TIPO 56
25	-----	FREIN FILET BLEU	THREAD LOCKER BLUE	AUTOBLOCANTE AZUL
26	-----	FREIN FILET ROUGE THREE BOND	THREAD LOCKER RED THREE BOND	AUTOBLOCANTE ROJO THREE BOND

Boite a vitesses / Gear set / Cambio

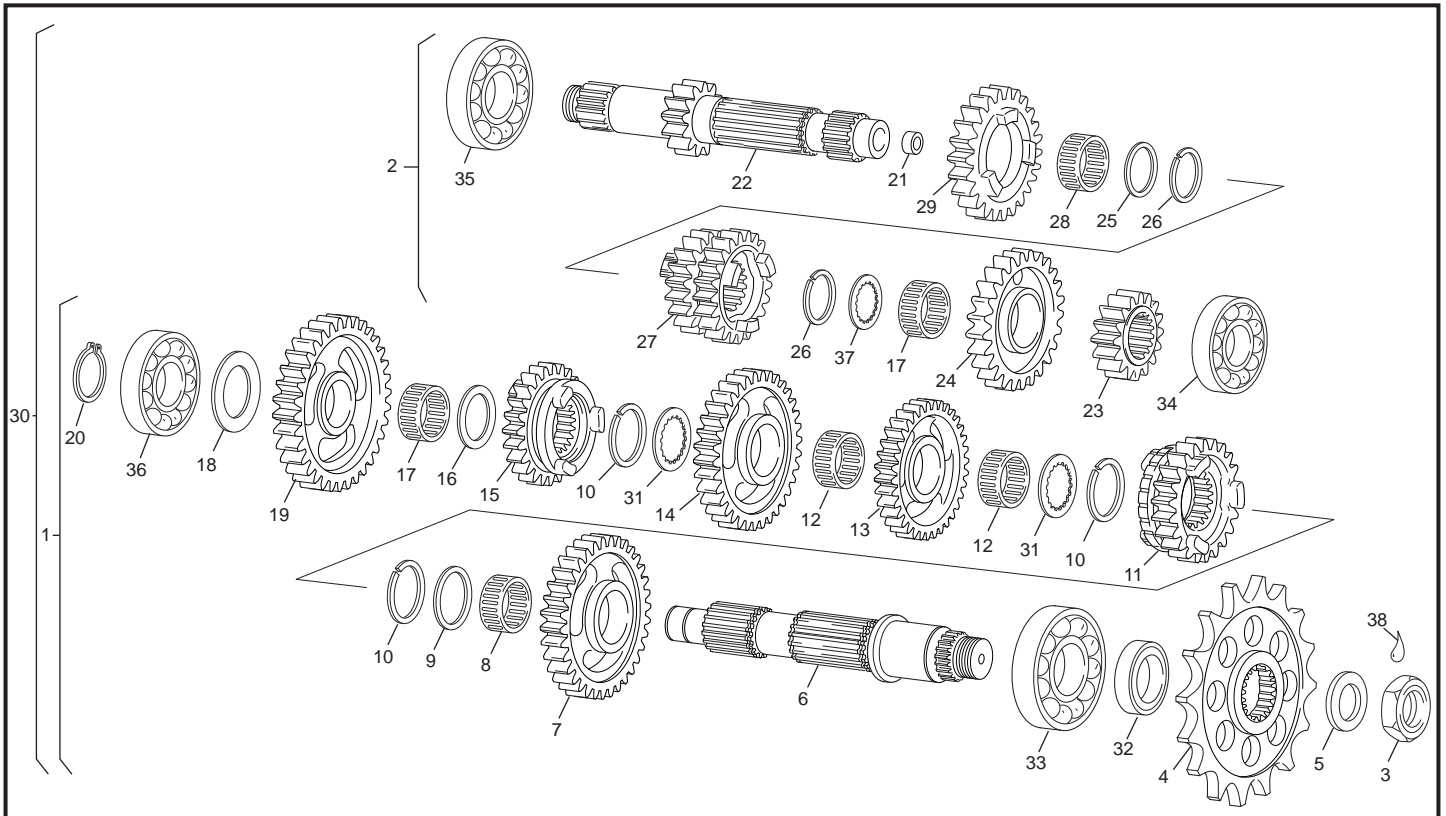

POS.	SE/SX 2.5 / 3,0i F/R	FRANÇAIS	ENGLISH	ESPAÑOL
1	1006	ARBRE SECONDAIRE CPL	SECONDARY SHAFT ASSY	EJE SECUNDARIO CPL
2	1005	ARBRE PRIMAIRE CPL	MAIN SHAFT ASSY	EJE PRIMARIO CPL
3	0994	ECROU M18X1	SCREW M18X1	TUERCA M18X1
4	1007	PIGNON CHAINE Z14	CHAIN PINION Z14	PIÑÓN CADENA Z14
4	1012	PIGNON CHAINE Z13	CHAIN PINION Z13	PIÑÓN CADENA Z13
5	1010	RONDELLE CONIQUE 18X35X2	WASHER SPRING 18X35X2	ARANDELA CÓNICA 18X35X2
6	1775	ARBRE SECONDAIRE	SECONDARY SHAFT	EJE SECUNDARIO
7	1776	PIGNON Z31 2 ÈME	PINION Z31 2nd.	PIÑÓN Z31 2nd.
8	1778	BAGUE AIGUILLES 24X28X14	SPACER BEARING 24X28X10	CASQUILLO AGUJAS 24X28X10
9	1779	RONDELLE 24.2X32X1.5	WASHER 24.2X32X1.5	ARANDELA 24.2X32X1.5
10	1780	CIRCLIP SW23	SNAP RING SW23	CIRCLIP SW23
11	1781	PIGNON Z22/6 ÈME	PINION Z22/6rd.	PIÑÓN DE Z22/6rd.
12	1782	BAGUE AIGUILLES 20X24X10	SPACER BEARING 20X24X10	CASQUILLO AGUJAS 20X24X10
13	1783	PIGNON Z26/4 ÈME	PINION Z26/4th.	PIÑÓN Z26/4º
14	1785	PIGNON Z28/3 ÈME	PINION Z28/3º	PIÑÓN Z28/3º
14	2331	PIGNON 3 Z23 250 END/MX EVO	GEAR 3TH Z23 250 END/MX EVO	PINON 3 Z23 250 END/MX EVO
15	1784	PIGNON Z24/5 ÈME	PINION Z24/5º	PIÑÓN Z24/5º
16	1787	RONDELLE 18.2X28X1.5	WASHER 18.2X28X1.5	ARANDELA 18.2X28X1.5
17	1786	BAGUE AIGUILLES 18X22X10	SPACER BEARING 18X22X10	CASQUILLO AGUJAS 18X22X10
18	1788	RONDELLE 17X28X1.5	WASHER 17X28X1.5	ARANDELA 17X28X1.5
19	1789	PIGNON Z34/1 ÈRE	PINION Z34/1.	PIÑÓN Z34/1º
20	M171	SEGMENT ARRET Ø17	RETAINING RING 17	SEEGER Ø17
21	1790	BAGUE BRONZE	SPACER	CASQUILLO
22	1791	ARBRE PRIMAIRE	MAIN SHAFT	EJE PRIMARIO
23	1792	PIGNON Z16/2 ÈME	PINION Z16/2nd.	PIÑÓN Z16/2nd.
24	1793	PIGNON Z25/6 ÈME	PINION Z25/6th.	PIÑÓN Z25/6st.
25	1794	RONDELLE 22.2X27.8X1	WASHER 22.2X27.8X1	ARANDELA 22.2X27.8X1
26	1795	CIRCLIP SW21	SNAP RING SW21	CIRCLIP SW21
27	1796	PIGNON Z19-21 3 ÈME ET 4 ÈME	PINION Z19-21/3º-4º	PIÑÓN Z19-21/3º-4º
27	2332	PIGNON 3/4 Z15/21 250 END/MX EVO1	GEAR 3/4 Z15/21 250 END/MX EVO1	PINON 3/4Z15/21 250 END MX EVO1
28	1797	BAGUE AIGUILLES 22X26X10	SPACER BEARING 22X26X10	CASQUILLO AGUJAS 22X26X10
29	1798	PIGNON Z23/5 ÈME	PINION Z23/5º	PIÑÓN Z23/5º
30	0890	BOITE A VITESSE CPL	COMPLETE GEAR SET	CTO. CAMBIO
31	1799	RONDELLE 24X31X1	WASHER 24X31X1	ARANDELA 24X31X1

Boite a vitesses / Gear set / Cambio

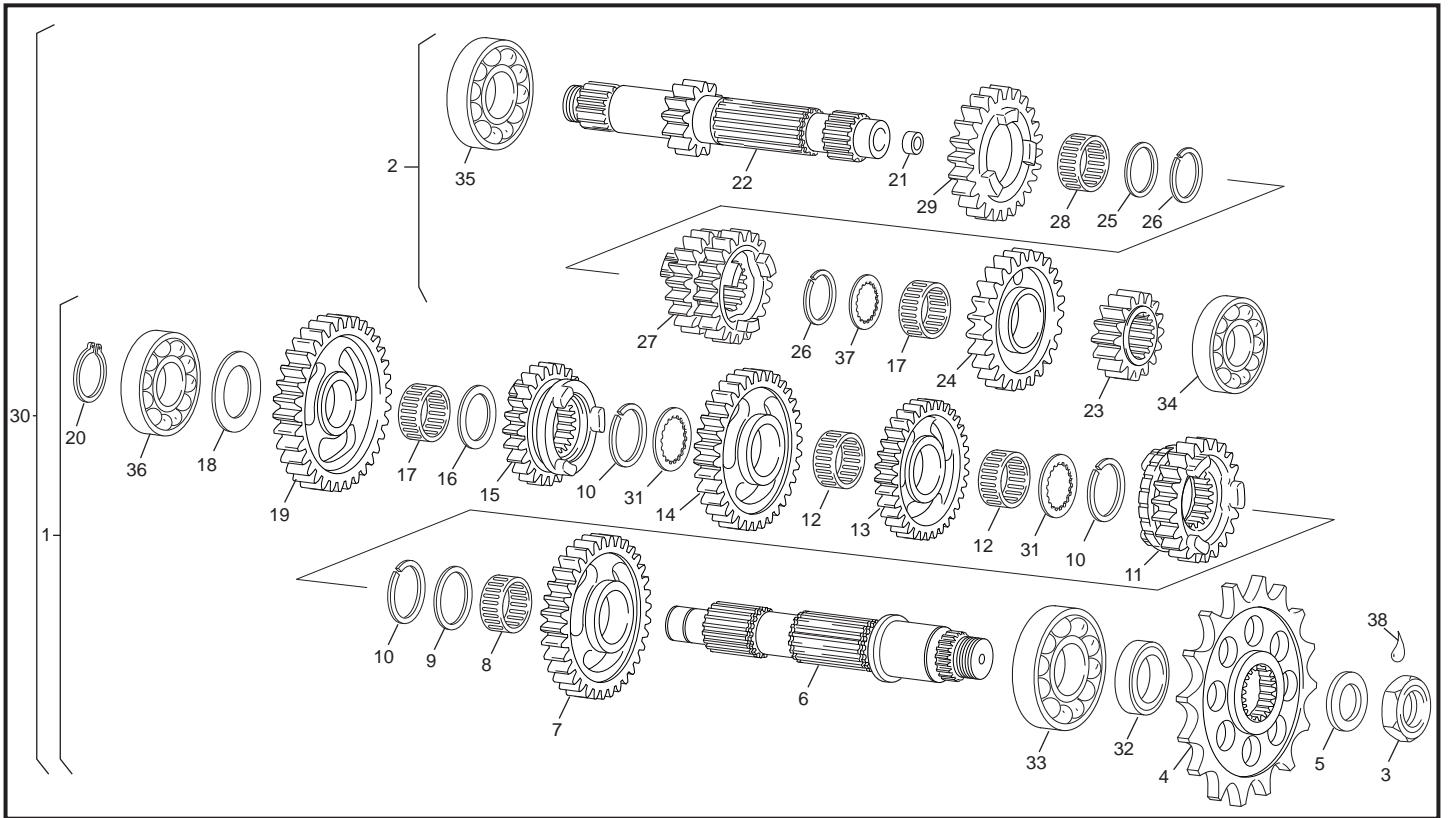

POS.	SE/SX 2.5 / 3,0i F/R	FRANÇAIS	ENGLISH	ESPAÑOL
32	0877	JOINT 25X37X6	SEAL 25X37X6	RETÉN 25X37X6
33	0174	ROULEMENTS 6205 C3	BEARING 6205 C3	RODAMIENTO 6205 C3
34	0875	ROULEMENTS 6003 C3 RS	BEARING 6003 C3 RS	RODAMIENTO 6003 C3 RS
35	0876	ROULEMENTS 6222 C3	BEARING 6222 C3	RODAMIENTO 6222 C3
36	0874	ROULEMENTS 6003 C3	BEARING 6003 C3	RODAMIENTO 6003 C3
37	1794	RONDELLE 19.5X27.8X1	WASHER 19.5X27.8X1	ARANDELA 19.5X27.8X1
38	-----	FREIN FILET ROUGE THREE BOND	THREAD LOCKER RED THREE BOND	AUTOBLOCANTE ROJO THREE BOND

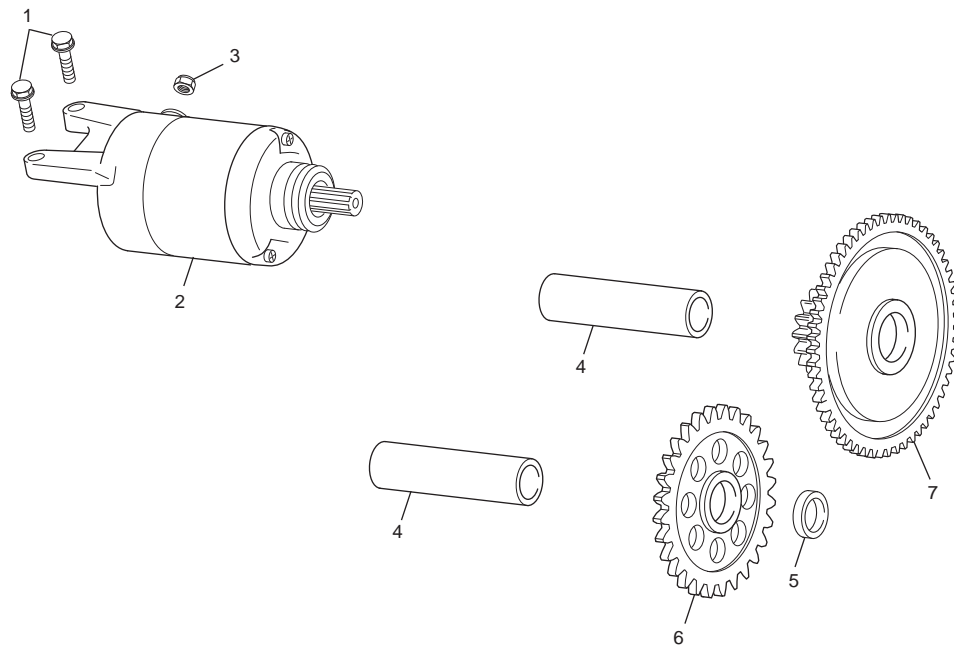
Demarreur / Starter Motor / Motor Starter

POS.	SE/SX 2.5 / 3,0i F/R	FRANÇAIS	ENGLISH	ESPAÑOL
1	0546	VIS TH EP M6X20	SCREW M6X20	TORNILLO M6X20
2	0972	DEMARREUR	START MOTOR	MOTOR STARTER
3	M306	ECROU M6	SCREW M6	TUERCA M6
4	0960	AXE	AXLE	EJE
5	0961	ENTRETOISE PIGNON INTER	SPACER	CASQUILLO
6	0958	PIGNON Z28	PINION Z28	PIÑÓN Z28
7	1995	LIMITEUR DE COUPLE 2.5i	TORQUE LIMITEUR 2.5i	LIMITADOR DE PAR 2.5i

Groupe carters / Crankcase assembly / Grupo carters

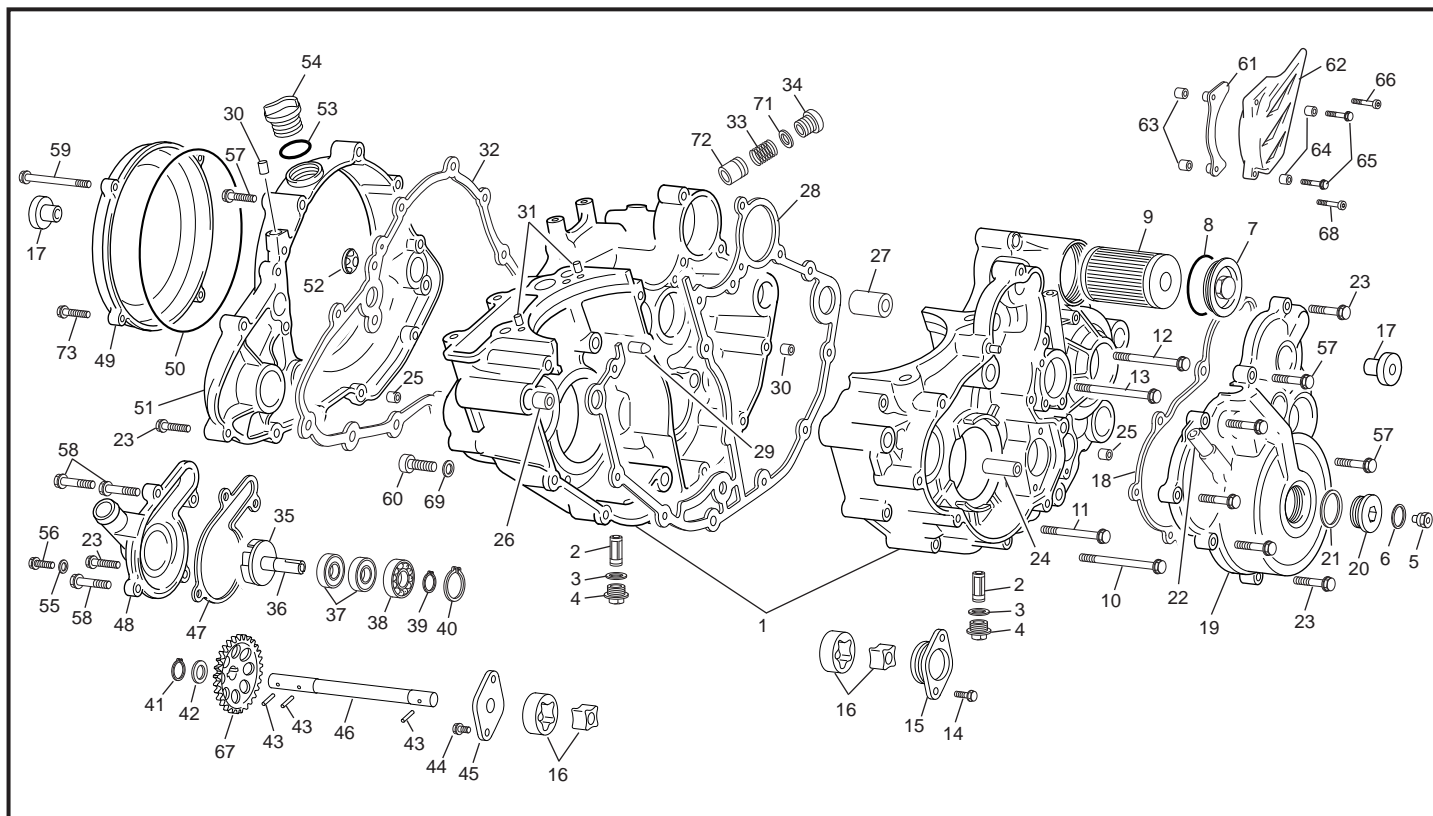

POS.	SE/SX 2.5 / 3,0i F/R	FRANÇAIS	ENGLISH	ESPAÑOL
1	0862	CARTER CENTRAL	CRANKCASE SET	CARTERS CENTRALES
2	0508	PREFILTRE	PREFILTER	PREFILTRO
3	0583	RONDELLE 18X22X1	WASHER	ARANDELA
4	0507	BOUCHON PREFILTRE	CAP	TAPÓN
5	0510	BOUCHON VIDANGE	CAP	TAPÓN
6	0610	RONDELLE 12X18	WASHER	ARANDELA
7	0117	COUVERCLE FILTRE HUILE	OIL FILTER CAP	TAPÓN FILTRO ACEITE
8	0118	JOINT TORIQUE 41X1.78	O RING 41X1.78	TÓRICA 41X1.78
9	0116	FILTRE A HUILE PAPIER	OIL FILTER	FILTRO ACEITE
10	0550	VIS TH EP M6X55	SCREW M6X55	TORNILLO M6X55
11	0551	VIS TH EP M6X60	SCREW M6X60	TORNILLO M6X60
12	0552	VIS TH EP M6X75	SCREW M6X75	TORNILLO M6X75
13	0550	VIS TH EP M6X55	SCREW M6X55	TORNILLO M6X55
14	0553	VIS TH EP M5X12	SCREW M5X12	TORNILLO M5X12
15	0947	COUVERCLE POMPE HUILE	OIL PUMP COVER	TAPA BOMBA ACEITE
16	0946	POMPE HUILE INT.	OIL PUMP	BOMBA ACEITE
17	1106	BAGUE CARTER	COLLAR BUSH	MANGUITO CARTER
18	0859	JOINT CARTER ALLUMAGE	COVER GASKET	JUNTA CARTER ENCENDIDO
19	2304	CARTER ALLUMAGE NOIR	IGNITION COVER BLACK	CARTER ENCENDIDO NEGRO
20	0966	BOUCHON CARTER ALLUMAGE	CAP	TAPÓN
21	M644	JOINT TORIQUE BOUCHON	O RING	RETÉN
22	1722	RACCORD VENTILATION	VENTILATION CONNECTION	CONECTOR TUBO VENTILACIÓN
23	0970	VIS TH EP M6X25	SCREW M6X25	TORNILLO M6X25
24	1580	AXE ROTOR RENIFLARD	ROTOR PIN	EJE ROTOR
25	0008	DOUILLE 8X6.5X10	DOWEL 8X6.5X10	CASQUILLO 8X6.5X10
26	0006	DOUILLE 14X11X16	DOWEL 14X11X16	CASQUILLO 14X11X16
27	0490	DOUILLE 21.5X17.5X18	DOWEL 21.5X17.5X18	CASQUILLO 21.5X17.5X18
28	0857	JOINT CÂRTER CENTRAL	CRANKCASE GASKET 250 END	JUNTA CARTER CENTRAL
29	0865	GICLEUR HUILE PISTÓN	PISTON OIL JET	CHICLE ACEITE PISTÓN
30	0866	GICLEUR HUILE VILO	GEARBOX OIL JET	CHICLE ACEITE CIGÜEÑAL
31	0864	AIGUILLE 5X10	NEEDLE 5X10	AGUJAS 5X10
32	0858	JOINT CÂRTER EMBRAYAGE	CLUTCH COVER GASKET	JUNTA EMBRAGUE CARTER
33	0950	RESSORT DE CLAPET	SPRING OF VALVE	RESORTE DE CLAPETA
34	0952	VIS CLAPET	SCREW PRESSURE VALVE	TORNILLO VÁLVULA PRESIÓN
35	0936	TURBINE POMPE EAU	WATER PUMP IMPELLER	TURBINA BOMBA AGUA
36	0935	AXE POMPE A EAU	AXE WATER PUMP	EJE BOMBA ACEITE
37	0940	JOINT SPI 12X24X5	SEAL 12X24X5	RETÉN 12X24X5

Groupe carters / Crankcase assembly / Grupo carters

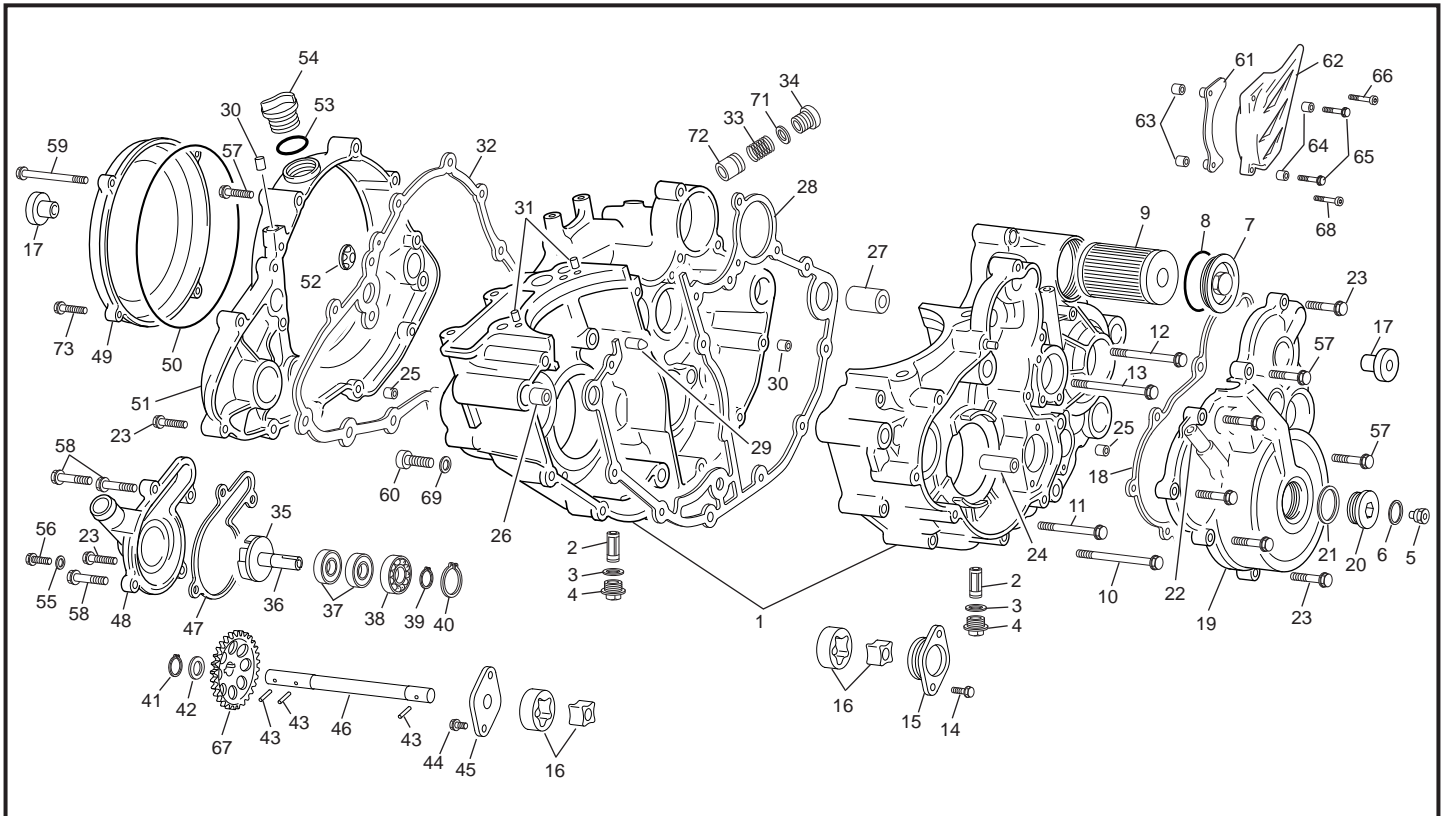

POS.	SE/SX 2.5 / 3,0i F/R	FRANÇAIS	ENGLISH	ESPAÑOL
38	0939	ROULEMENT 16100	BEARING 16100	COJINETE 16100
39	0096	CIRCLIP B10	SNAP RING	CIRCLIP
40	0942	CIRCLIP B28	SNAP RING	CIRCLIP
41	0080	CIRCLIP	SNAP RING	CIRCLIP
42	0955	RONDELLE 8X12X1	WASHER 8X12X1	ARANDELA 8X12X1
43	0954	AIGUILLE 2.5X11.8	NEEDLE 2.5X11.8	AGUJA 2.5X11.8
44	0553	VIS TH EP M5X12	SCREW TH EP M5X12	TORNILLO TH EP M5X12
45	0948	CLOISON DE POMPE HUILE	OIL PUMP COVER	TAPA BOMBA ACEITE
46	0945	AXE POMPE A HUILE	SHAFT OIL PUMP	EJE BOMBA ACEITE
47	0937	JOINT DE POMPE A EAU	WATER PUMP GASKET	JUNTA BOMBA AGUA
48	0938	COUVERCLE POMPE A EAU	WATER PUMP COVER	TAPA BOMBA AGUA
49	2303	COUVERCLE EMBRAYAGE NOIR	COVER CLUTCH BLACK	TAPA EMBRAGUE NEGRA
50	0989	JOINT COUVERCLE EMBRAYAGE	COVER CLUTCH GASKET	JUNTA TAPA EMBRAGUE
51	0980	CARTER EMBRAYAGE	CLUTCH CRANKASE	CARTERS EMBRAGUE
52	0029	VOYANT NIVEAU HUILE	OIL LEVEL GAUGE	VISOR NIVEL ACEITE
53	0606	JOINT TORIQUE 12X2	OIL SEAL 12X2	JUNTA
54	0509	BOUCHON	CAP	TAPA
55	0601	RONDELLE ALU	WASHER ALU	ARANDELA
56	0592	VIS TH EP M6X8	SCREW M6X8	TORNILLO M6X8
57	0547	VIS TH EP M6X30	SCREW M6X30	TORNILLO M6X30
58	0548	VIS TH EP M6X35	SCREW M6X35	TORNILLO M6X35
59	0552	VIS TH EP M6X60	SCREW M6X60	TORNILLO M6X60
60	0855	VIS SPECIAL BOUCHON NINTOR	SCREW	TORNILLO
61	1588	PROTECTEUR PIGNON CHAINE	CASE PROTECTOR	PROTECTOR PIÑÓN CADENA
62	0538	CARTER PIGNON SORTIE BOITE	DRIVE SPROCKET COVER	CARTER PROTECTOR PIÑÓN CADENA
63	1701	ENTRETOISE	SPACER	CASQUILLO
64	0008	DOUILLE	DOWEL	CENTRADOR
65	0656	VIS TH EP M6X16	SCREW TH EP M6X16	TORNILLO TH EP M6X16
66	1720	VIS CHC TÊTE BASSE M6X25	SCREW M6X25	TORNILLO M6X25
67	0944	PIGNON POMPE HUILE	OIL PUMP PINION	PIÑÓN BOMBA ACEITE
68	1721	VIS CHC TÊTE BASSE M6X30	SCREW M6X30	TORNILLO M6X30
69	0951	RONDELLE ALU 14X20X1.5	WASHER 14X20X1.5	ARANDELA 14X20X1.5
70	1823	ENSEMBLE CARTERS CENTRAUX	CRANKASE SET	JUEGO CARTERS COMPLETO
71	0951	RONDELLE ALUMINIUM	ALUMINIUM WASHER	ARANDELA ALUMINIO
72	0949	PISTON CLAPET DE DÉCHARGE	PISTON PRESSURE VALVE	PISTÓN PRESIÓN VÁLVULA
73	0546	VIS TH EP M6X20	SCREW M6X20	TORNILLO M6X20

Villebrequin assemble / Crankshaft assembly / Cigüeñal biela

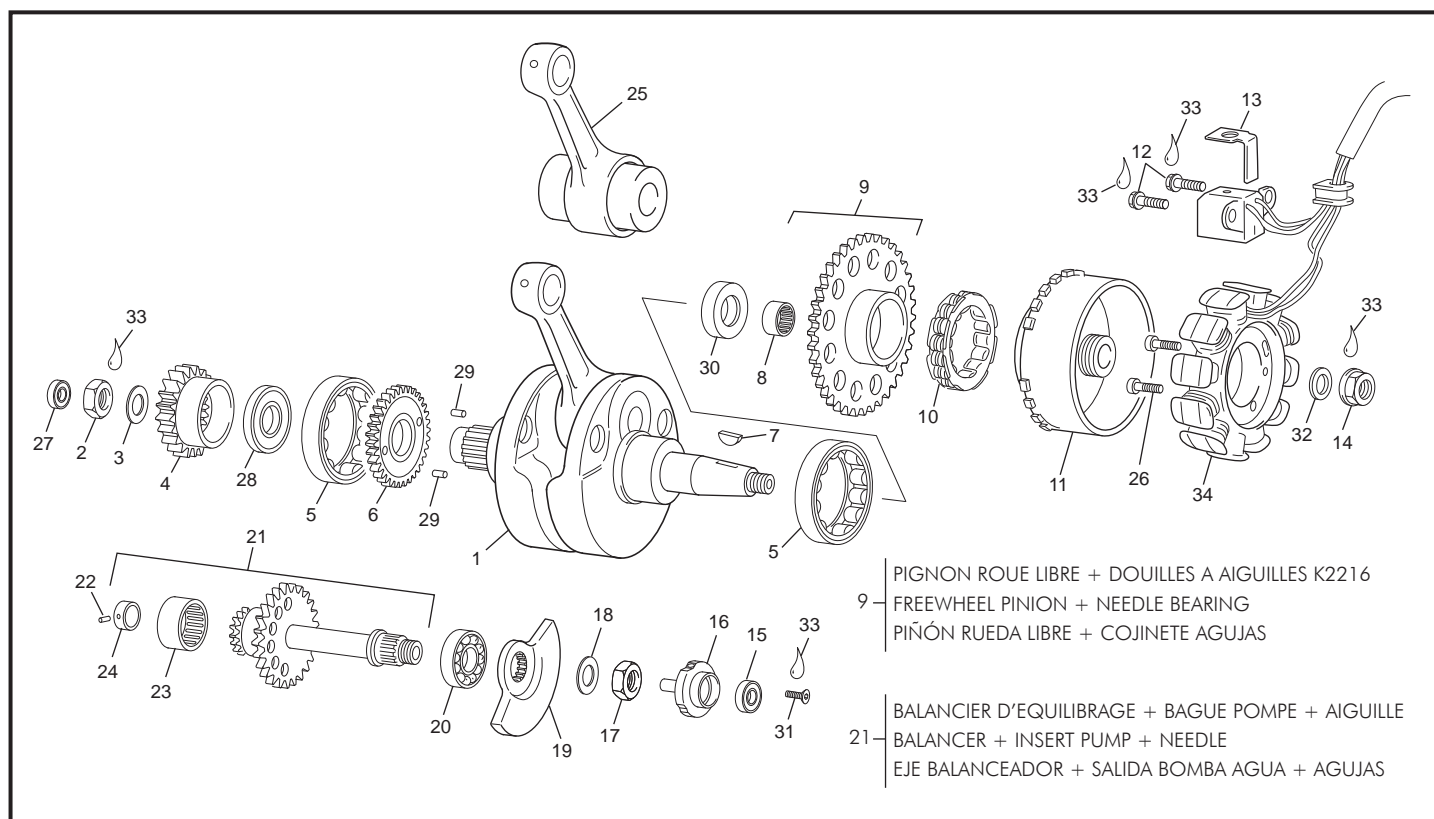

POS.	SE/SX 2.5 F/R	SE 3.0i F/R	FRANÇAIS	ENGLISH	ESPAÑOL
1	0863	2336	VILEBREQUIN COMPLET	CRANKSHAFT ASSEMBLY	CIGÜEÑAL
2	0051	0051	ECROU M20X1	SCREW M20X1	TUERCA M20X1
3	0050	0050	RONDELLE 21X32X1.2	WASHER 21X32X1.2	ARANDELA 21X32X1.2
4	0976	0976	PIGNON PRIMAIRE Z21	CLUTCH SHAFT PINION	PIÑÓN PRIMARIO
5	1592	1592	ROULEMENTS ROULEAUX NJ206 EPC/C3	ROLLER BEARING NJ206 EPC/C3	COJINETE ROL. NJ206 EPD/C3
6	0852	0852	PIGNON VILEBREQUIN Z25	CRANKSHAFT PINION Z25	PIÑÓN CIGÜEÑAL Z25
7	0055	0055	CLAVETTE	WOODURFF	CHAVETA
8	0290	0290	DOUILLES A AIGUILLES K2216	NEEDLE BEARING	COJINETE AGUJAS
9	0957	0957	PIGNON ROUE LIBRE Z49	FREEWHEEL PINION	PIÑÓN RUEDA LIBRE
10	0962	0962	ROUE LIBRE	FREEWHEEL	RUEDA LIBRE
11	1893	1893	ROTOR	ROTOR	ROTOR
12	0553	0553	VIS TH EP M5X12	SCREW M5X12	TORNILLO M5X12
13	0964	0964	PATTE MAINTIEN FIL ALLUMAGE	IGNITION WIRING CLAMP	PATA SOPORTE HILO ENCENDIDO
14	1405	1405	ECROU M12X1	SCREW M12X1	TUERCA M12X1
15	0660	0660	JOINT 14X24X6	SEAL 14X24X6	RETÉN 14X24X6
16	1581	1581	ROTOR RENIFLARD	BREATHER WHEEL	CENTRIFUGADOR
17	0861	0861	ECROU SCPECIAL M14X1	SCREW M14X1	TUERCA M14X1
18	0887	0887	RONDELLE 14.2X28X1.5	WASHER 14.2X28X1.5	ARANDELA 14.2X28X1.5
19	0851	0851	MASSE D'EQUILIBRAGE	BALANCER WEIGHT	MASA DE EQUILIBRAJE
20	0870	0870	ROULEMENTS 6203	BEARING 6203	COJINETE 6203
21	0849	0849	BALANCIER D'EQUILIBRAGE	BALANCER SHAFT	EJE BALANCEADOR
22	0110	0110	AIGUILLE 3X15	NEEDLE 3X15	AGUJAS 3X15
23	0871	0871	ROULEMENTS AIGUILLE 4905	BEARING	COJINETES
24	0853	0853	BAGUE POMPE A EAU	INSERT PUMP DRIVE	SALIDA BOMBA AGUA
25	1512	1512	KIT BIELLE 250	CRANKSHAFT REPAIR KIT 250	KIT BIELA 250
26	M250	M250	VIS CHC M5X16/1250	SCREW M5X16	TORNILLO M5X16
27	0891	0891	JOINT 8X18X5	SEAL 8X18X5	RETÉN 8X18X5
28	0873	0873	JOINT 36X54X7.5	SEAL 36X54X7.5	RETÉN 36X54X7.5
29	0864	0864	AIGUILLE 5X1.0	NEEDLE 5X1.0	AGUJAS 5X1.0
30	1732	1732	ENTRETOISE VILEBREQUIN	SPACER CRANKSHAFT	CASQUILLO CIGÜEÑAL
31	0872	0872	VIS FHC M5X20	SCREW FHC M5X20	TORNILLO FHC M5X12
32	1963	1963	RONDELLE BELLEVILLE 12,2X23X1	SPING WASHER 12,2X23X1	ARANDELA BELLEVILLE 12,2X23X1
33	-----	-----	FREIN FILET ROUGE THREE BOND	THREAD LOCKER RED THREE BOND	AUTOBLOCANTE ROJO
34	0968	0968	STATOR	STATOR	STATOR

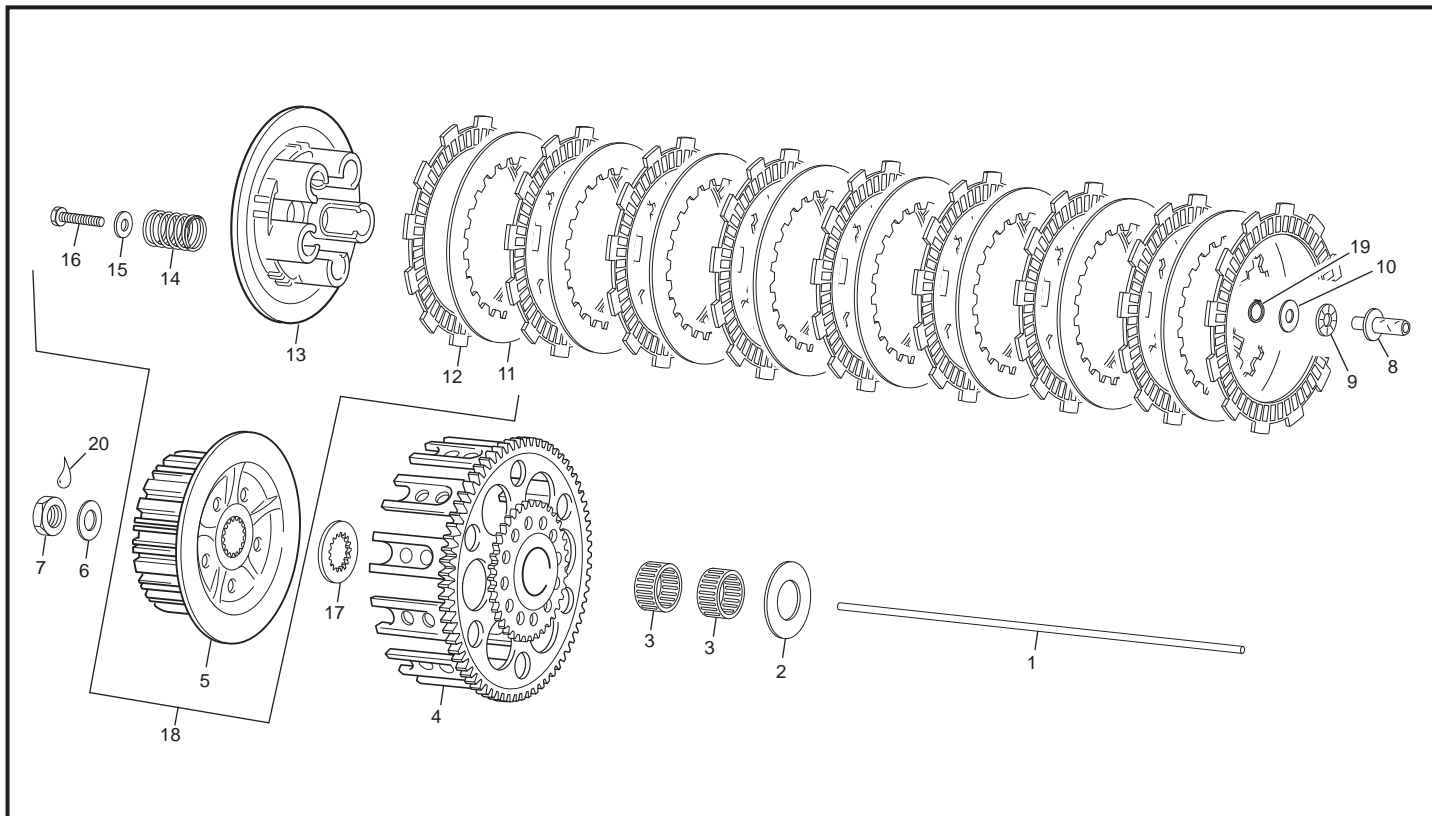
Embrayage / Clutch / Embrague

POS.	SE/SX 2.5 / 3,0i F/R	FRANÇAIS	ENGLISH	ESPAÑOL
1	0982	TIGE DE POUSSEE	CLUTCH ACTUATING ROD	VARILLA EMB
2	0990	RONDELLE 22.2X40X1.5	WASHER 22.2X40X1.5	ARANDELA 22.2X40X1.5
3	0992	DOUILLE AIGUILLES 22X26X10	NEEDLE DOWEL 22X26X10	CASQUILLO AGUJAS 22X26X10
4	0977	CLOCHE + PIGNON Z48	CLUTCH BASKET + PINION Z48	CAMPANA EMBRAGUE + PIÑÓN Z48
5	0986	NOIX D'EMBRAYAGE	CLUTCH HUB	CUBO EMBRAGUE
6	1010	RONDELLE 18X35X2	WASHER 18X35X2	ARANDELA 18X35X2
7	0994	ECROU M18X1	SCREW M18X1	TUERCA M18X1
8	0983	POUSSOIR DE PLATEAU	CLUTCH RELEASE	PULSADOR AXIAL
9	0997	BUTEE AIGUILLE	NEEDLE THRUST BEARING	CORONA COJINETE AGUJAS
10	0998	RONDELLE 8X21X1	WASHER 8X21X1	ARANDELA 8X21X1
11	0985	DISQUE LISSE	METAL DISC	DISCO EMBRAGUE METÁLICO
12	0984	DISQUE GARNI	FRICTION DISC	DISCO EMBRAGUE FORRADO
13	0987	PLATEAU	CLUTCH SPRING HOLDER	PLATO EMBRAGUE
14	0988	RESSORT EMB.	CLUTCH SPRING	MUELLE EMB.
15	0995	RONDELLE 6X18X1.5	WASHER 6X18X1.5	ARANDELA 6X18X1.5
16	0996	VIS TH M6X30	SCREW M6X30	TORNILLO M6X30
17	0991	RONDELLE BUTEE CRENELEE	SPACER WASHER	ARANDELA CRENELEE
18	0854	GROUPE EMBRAYAGE COMPLET	CLUTCH GRUPO	GRUPO EMBRAGUE COMPLETO
19	0080	CIRCLIP	CIRCLIP	SERCLIP
20	-----	FREIN FILET ROUGE THREE BOND	THREAD LOCKER RED THREE BOND	AUTOBLOCANTE ROJO THREE BOND

Cylindre / Cylinder / Cilindro

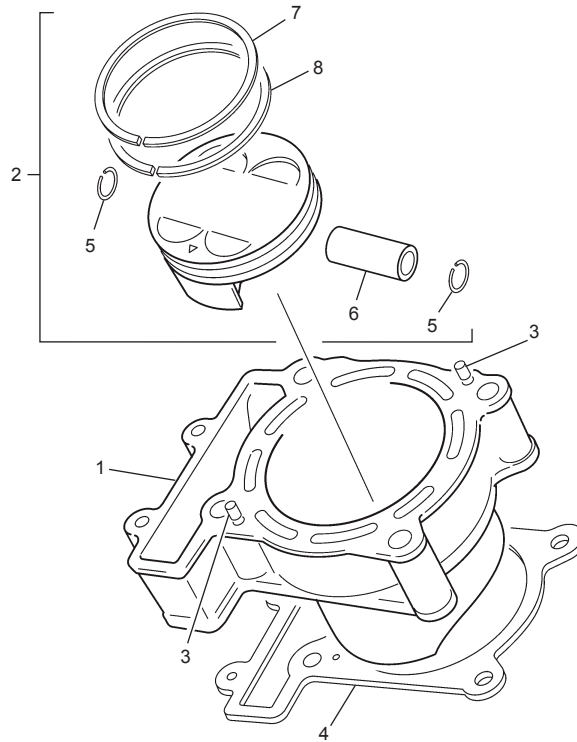

1836 (2) (Ø 84)	2337
	2338
	0850
	2380
0845 (2) (Ø 78)	0847
	0848
	0850
	0846

POS.	SE/SX 2,5l F/R	SE 3,0l F/R	FRANÇAIS	ENGLISH	ESPAÑOL
1	0893	1759	CYLINDRE	CYLINDER	CILINDRO
2	0845	1836	PISTON COMPLET	PISTON ASS	PISTÓN COMPLETO
3	0864	-----	AIGUILLE 5X10	NEEDLE 5X10	AGUJAS 5X10
4	3017	3017	JOINT EMBASE	CYLINDER GASKET	JUNTA CILINDRO
5	0850	-----	CIRCLIP	CIRCLIP	SERCLIP
6	0846	2380	AXE DE PISTON	PISTON PIN	BULÓN PISTÓN
7	0847	2337	SEGMENT DE FEU	COMPRESSION RING	ARO DE COMPRESIÓN
8	0848	2338	SEGMENT RACLEUR HUILE	OIL RING PISTON	ARO ENGRASE PISTÓN

Culasse / Cylinder head / Culata

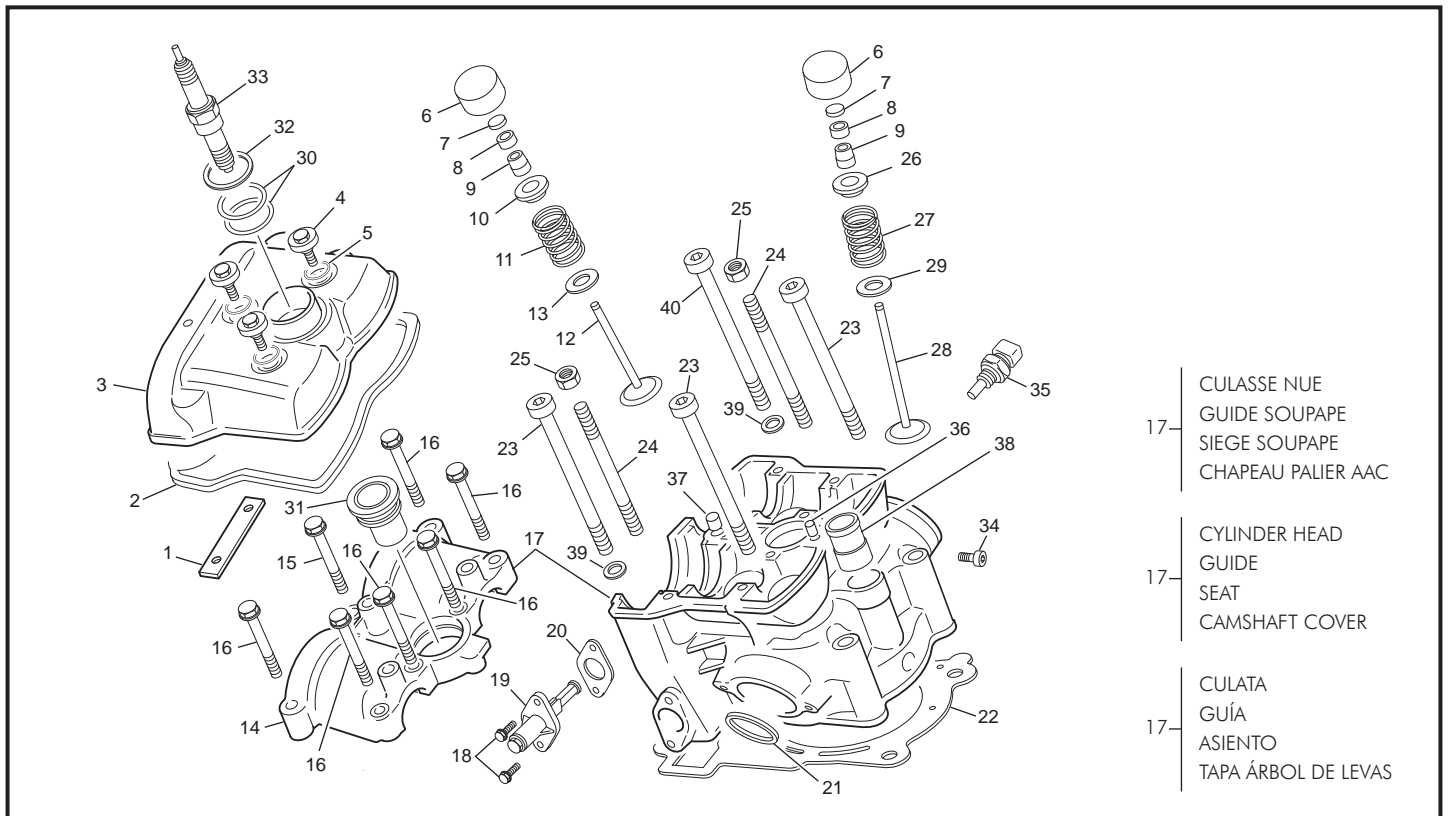

Culasse / Cylinder head / Culata

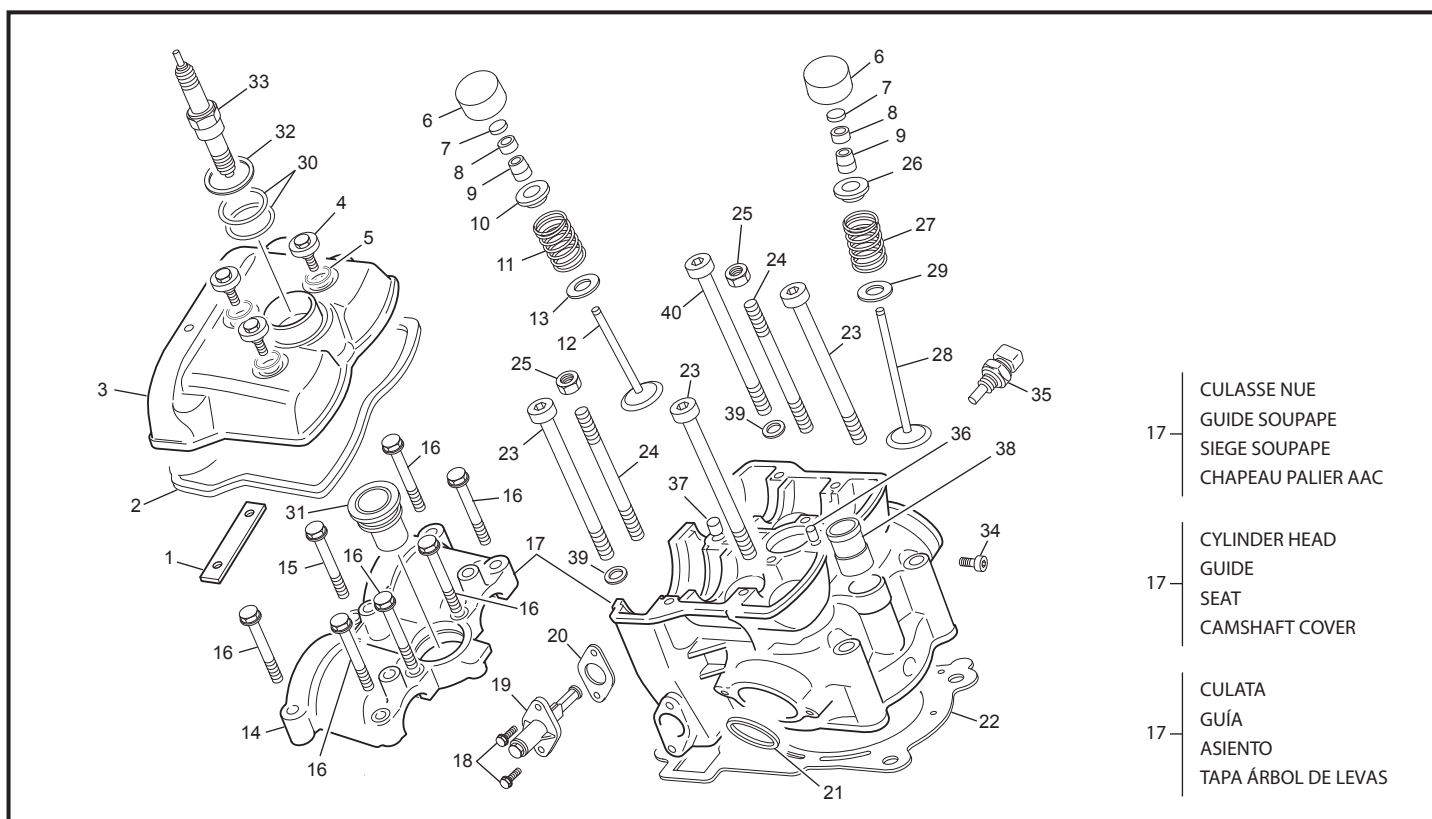

POS	SE/SX 2,5I F/R	SE 3,0i F/R	FRANÇAIS	ENGLISH	ESPAÑOL
8	0930	0930	DEMI CONE	VALVE SPRING RETAINER	SEMICONO VÁLVULA
9	0934	0934	JOINT SOUPAPPE	VALVE SEAL	RETÉN VÁLVULA
10	1519	1519	COUPELLE DE SOUPAPE D'ÉCHAPEMENT	EXHAUST VALVE SPRING CAP	SOMBRETERE VÁLVULA ESCAPE
11	0932	0932	RESSORT SOUPAPE D'ÉCHAPEMENT	INTAKE VALVE SPRING	MUELLE VÁLVULA ESCAPE
12	0928	0928	SOUPAPES D'ÉCHAPEMENT	EXHAUST VALVE	VÁLVULA ESCAPE
13	1518	1518	SIEGE DE RESSORT D'ÉCHAPEMENT	VALVE SPRING WASHER	ARANDELA MUELLE VÁLVULA END
14	0909	0909	CHAPERU PALIER ARBRE A CAME	CAMSHAFT COVER	TAPA ÁRBOL DE LEVAS
15	0548	0548	VIS TH EP M6X35	SCREW TH EP M6X35	TORNILLO TH EP M6X35
16	0547	0547	VIS TH EP M6X30	SCREW TH EP M6X30	TORNILLO TH EP M6X30
17	0894	3018	CULASSE ASSEMBLE COMPLET	CYLINDER HEAD ASSEMBLY COMPLETE	CONJUNTO CULATA COMPLETE
18	0656	0656	VIS TH EP M6X16	SCREW TH EP M6X16	TORNILLO TH EP M6X16
19	0921	0921	TENDEUR DE CHAINE	CHAIN TENSIONER ASSEMBLY	TENSOR CADENA DISTRIB.
20	0922	0922	JOINT TENDEUR	GASKET	JUNTA TENSOR
21	1766	1766	JOINT D'ÉCHAPEMENT	EXHAUST GASKET	JUNTA ESCAPE
22	3114	3016	JOINT DE CULASSE	CYLINDER HEAD GASKET	JUNTA CULATA
23	0896	0896	VIS M10X115	SCREW M10X115	TORNILLO M10X115
24	0898	0898	GOUJON CYLINDRE M6	PIN M6	GAVIA M6
25	M271	M271	ECROU M6	HEXNUT M6	TUERCA M6
26	0929	0929	COUPELLE DE SOUPAPE D'ADMISSION	INLET VALVE SPRING CAP	SOMBRETERE VÁLVULA ADMISIÓN
27	0931	0931	RESSORT SOUPAPPE D'ADMISSION	INLET VALVE SPRING	MUELLE VÁLVULA ADMISIÓN
28	0927	0927	SOUPAPES D'ADMISSION	INLET VALVE	VÁLVULA ADMISIÓN
29	0933	0933	SIEGE DE RESSORT D'ADMISSION	INLET VALVE SPRING WASHER	ARANDELA MUELLE VÁLVULA ADMISIÓN
30	0969	0969	JOINT TORIQUE 28X2 MBR	O RING 28X2 NBR	JUNTA 28X2 NBR
31	0895	0895	PUIT DE BOUGIE	TUBE WELL OK SPARK	TUBO PAZO BUJÍA
32	0899	0899	PUIT DE PUIT DE BOUGIE	SPARK GASKET	JUNTA BUJÍA
33	0431	0431	BOUGIE	SPARK	BUJÍA
34	1969	1969	VIS M6X10	SCREW M6X10	TORNILLO M6X10
35	0380	0380	CAPTEUR EAU	WASHER SENSOR	SENSOR AGUA
36	0864	0864	AIGUILLE 5X10	NEEDLE 5X10	AGUJA 5X10
37	0008	0008	DOUILLE DE CENTRAGE	DOWEL	CENTRADOR
38	0464	0464	RACCORD CULASSE DURITE	WATER CONNECTION	CONECTOR TUBO
39	C424	C424	RONDELLE M10	WASHER M10	ARANDELA M10
40	0897	0897	VIS M10X125	SCREW M10X125	TORNILLO M10X125
41	1813	1813	GUIDE SOUPAPE 250	VALVE GUIDE 250	GUÍA VALVULA 250

Distribution / Camshaft and drive assembly / Distribución

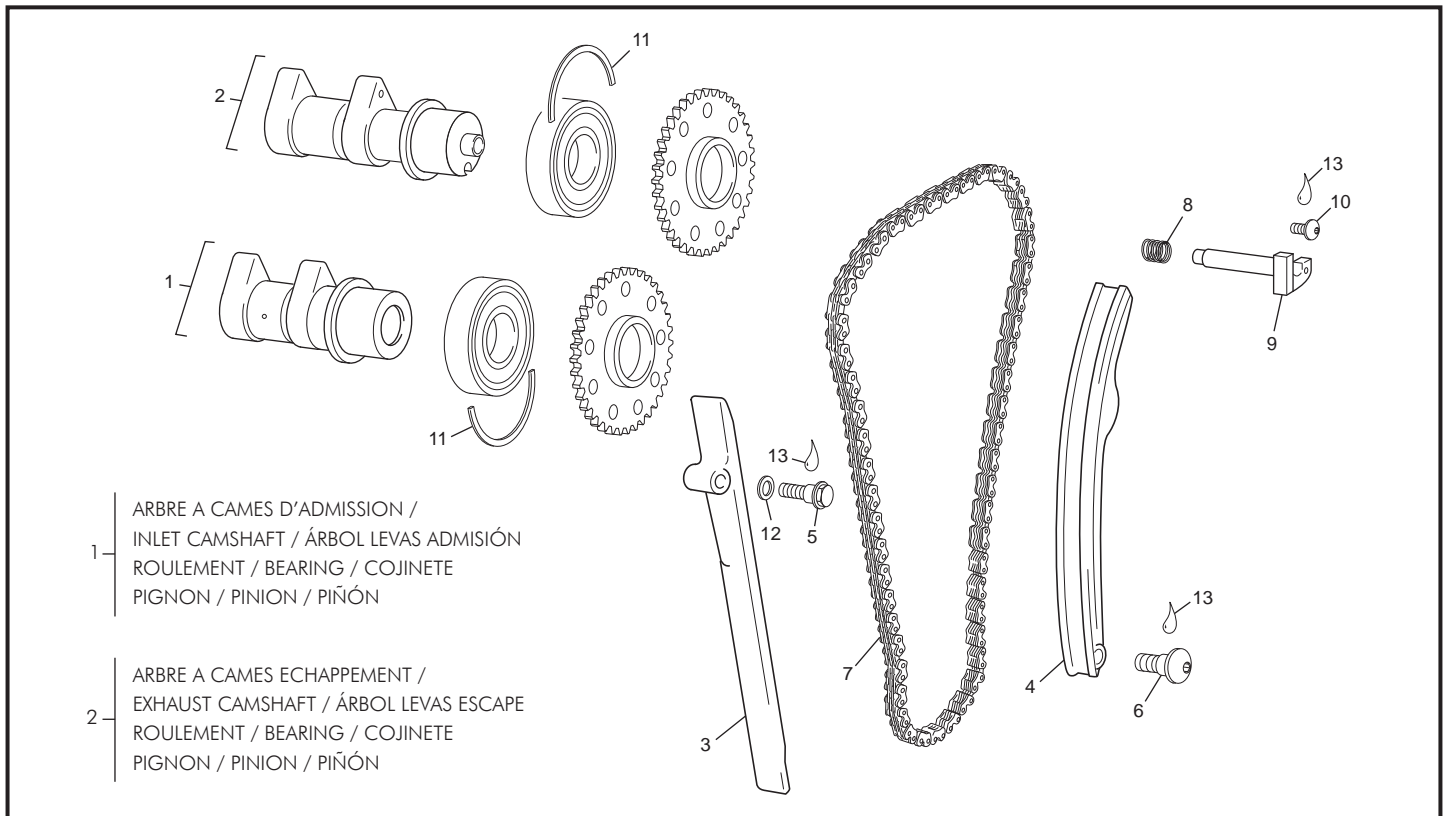

POS.	SE/SX 2.5 / 3,0i F/R	FRANÇAIS	ENGLISH	ESPAÑOL
1	1800	ARBRE A CAMES D'ADMISSION	INLET CAMSHAFT ASS.	ÁRBOL LEVAS ADMISIÓN
2	1801	ARBRE A CAMES ECHAPPEMENT	EXHAUST CAMSHAFT ASS.	ÁRBOL LEVAS ESCAPE
3	0913	GUIDE CHAINE DISTRIBUTION	CHAIN GUIDE	GUÍA CADENA DISTRIBUCIÓN
4	0914	PATÍN TENDEUR CHAINE DITRIB.	CHAIN GUIDE	PATÍN CADENA DISTRIBUCIÓN
5	0915	VIS SPECIAL TH M8	SCREW M8	TORNILLO M8
6	0916	VIS SPECIAL M6	SCREW M6	TORNILLO M6
7	1892	CHAINE E218 DISTRIBUTION	CAMSHAFT	CADENA DISTRIBUCIÓN
8	1511	RESSORT DECOMPRESSEUR	DECOMPRESSOR SPRING	MUELLE DESCOMPRESOR AUTO
9	1510	DECOMPRESSEUR	DECOMPRESSOR	DESCOMPRESOR
10	1687	VIS BHC EP M5X10	SCREW M5X10	TORNILLO M5X10
11	0926	DEMI SEGMENT D'ARRET	HALF LINE	SEMI SEGMENTO
12	0120	RONDILLE M8	WASHER M8	ARANDELA M8
13	-----	FREIN FILET ROUGE THREE BOND	THREAD LOCKER RED THREE BOND	AUTOBLOCANTE ROJO THREE BOND

Corps injection / Injector body / Cuerpo inyección

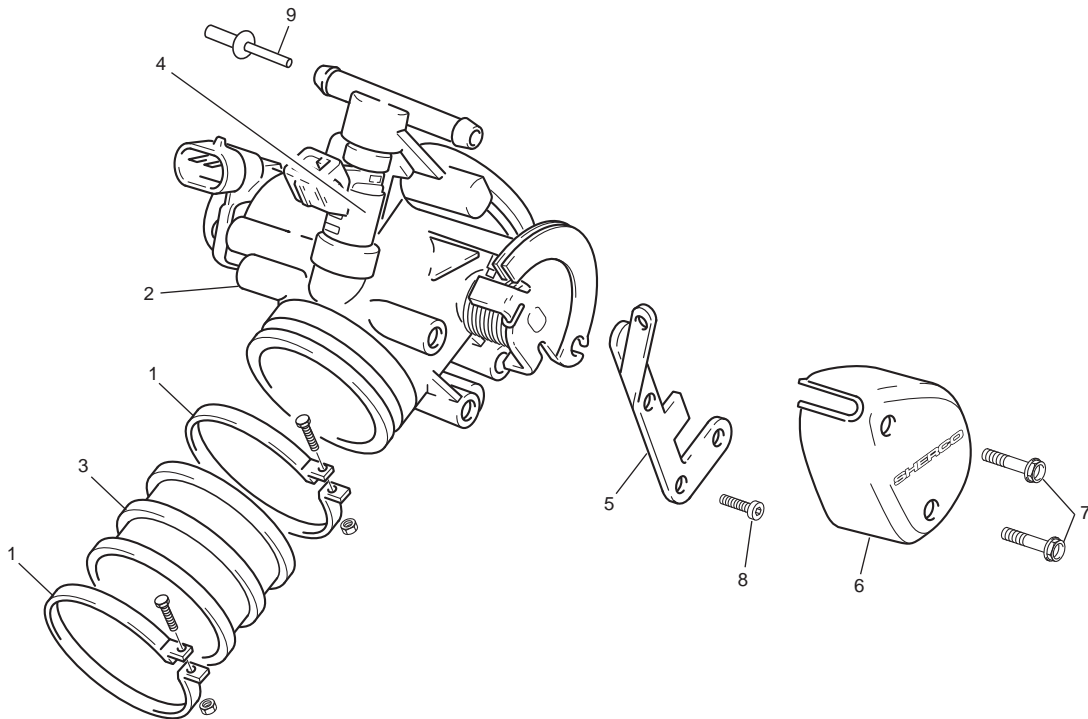

POS.	SE/SX 2.5 / 3,0i F/R	FRANÇAIS	ENGLISH	ESPAÑOL
1	0595	COLLIER KC060 MANCHÓN CORP INJ.	HOSE CLAMP	BRIDA TOBERA KC060 CUERPO INYEC.
2	2194	CORP D'INJECTION 250/300	INJECTOR BODY 250/300	CUERPO INYECCIÓN 250/300
3	0377	MANCHÓN CULASSE/INJECTION	MANIFOLD - CYLIND. HEAD TO INJECT.	TOBERA CULATA/INYECCIÓN
4	2195	INJECTEUR 250/300	INJECTOR 250/300	INYECTOR 250/300
5	0539	SUPPORT CABLE GAZ	THROTTLE CABLE BRACKET	SOPORTE CABLE DE GAS
6	0540	COUVERCLE CORP INJECTION	INJECTOR COVER	TAPA CORPO INYECCIÓN
7	0554	VIS TH EP 5X20	SCREW 5X20	TORNILLO 5X20
8	0655	VIS THEP 5X10	SCREW 5X10	TORNILLO 5X10
9	1273	RIVET	RIVET	REMACHE

Outillage / Tools / Utilajes

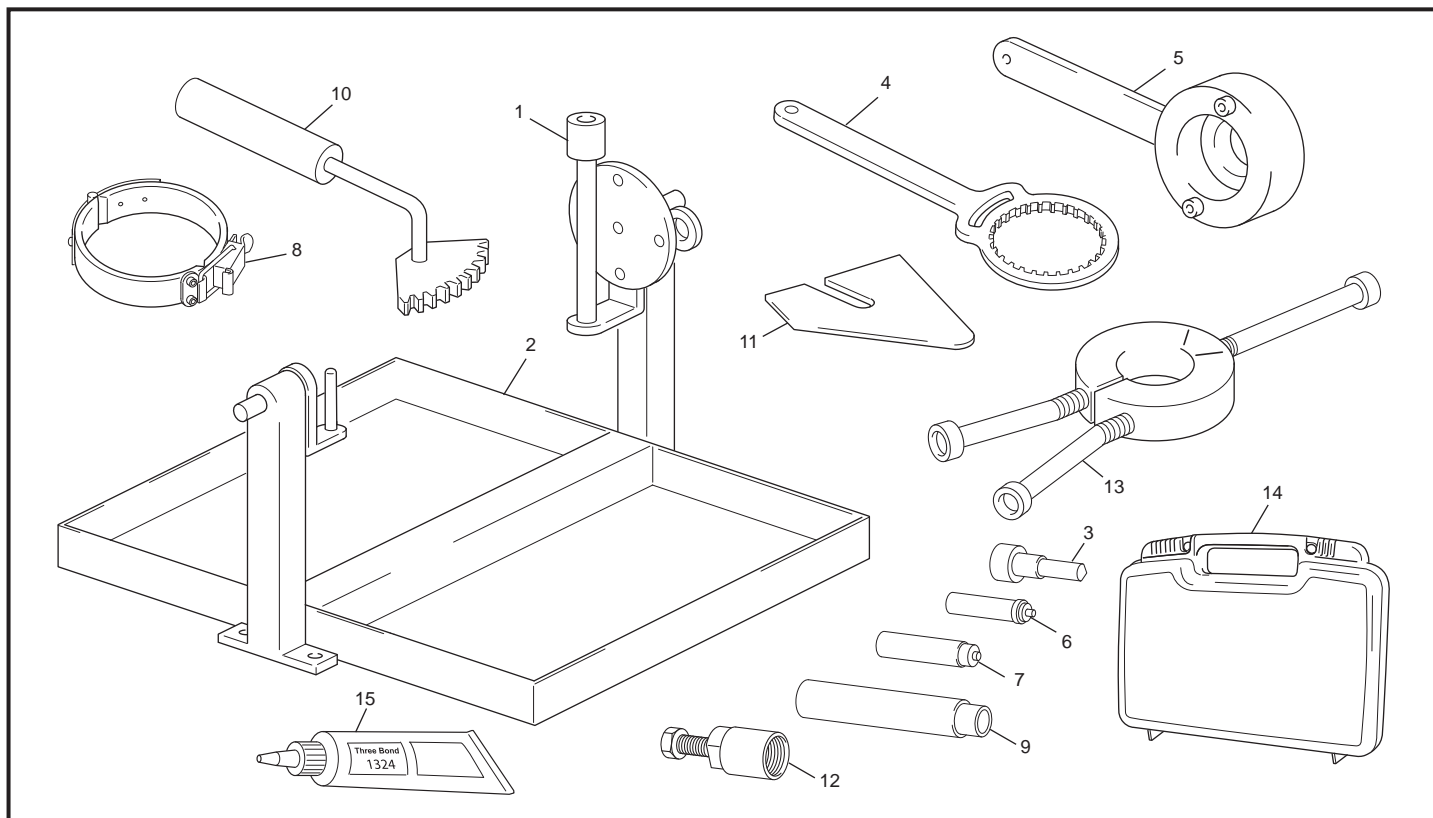

POS.	SE/SX 2.5 / 3,0i F/R	FRANÇAIS	ENGLISH	ESPAÑOL
1	1821	OUTIL SUPPORT MOTEUR	ENGINE SUPPORT TOOL	ÚTIL SOPORTE MOTOR
2	R481	SERVANTE	CONTAINER	BANDEJA
3	1819	VIS MISE AU PMH	DEAD POINT SCREW	TORNILLO ÚTIL PUNTO MUERTO SUP.
4	1814	OUTIL CLOCHE EMBRAYAGE	CLUTCH HOLDER TOOL	ÚTIL CAMPANA EMBRAGUE
5	1815	OUTIL BLOC ALLUMAGE	IGNITION HOLDER TOOL	ÚTIL ENCENDIDO
6	1822	OUTIL ROULEMENT AXE POMPE À EAU	WATER PUMP BEARING TOOL	ÚTIL ROD. BOMBA DE AGUA
7	1968	OUTIL SPY POMPE À EAU	OIL SEAL WATER PUMP TOOL	ÚTIL OIL SEAL BOMBA DE AGUA
8	1816	SERRE SEGMENT	RING TOOL	ÚTIL AROS
9	R450	OUTIL MONTAGE SPY SÉLECTEUR	OIL SEAL GEAR SHIFT LEVER TOOL	ÚTIL RETÉN PALANCA CAMBIO
10	1817	OUTIL BLOC PIGNON PRIMAIRE	PINION CLUTCH SHAFT TOOL	ÚTIL PIÑÓN PRIMARIO
11	1818	SUPPORT PISTON	PISTON SUPPORT	APOYO PISTÓN
12	R462	EXTRACTEUR VOLANT	FLYWHEEL PULLER	EXTRACTOR VOLANTE
13	R464	EXTRACTEUR ANEAU	RING EXTRACTOR	EXTRACTOR ANILLO
14	R471	OUTIL DIAGNOSTIQUE INJECTION	DIAGNOSTIC TOOL INJECTOR	ÚTIL DIAGNÓSTICO INYECCIÓN
15	-----	FREIN FILET ROUGE THREE BOND	THREAD LOCKER RED THREE BOND	AUTOBLOCANTE ROJO THREE BOND



created by www.clandisseny.com

SHERCO
www.sherco.com

2010



MICHELIN

Leonelli
INFIANTI DI ACCENSIONE IGNITION SYSTEMS

MINERVA OIL

SKF

SHERCO
Motorcycles