

SHERCO

SPARE PARTS

SPARE PARTS BOOK '21

125 SE-R

1 Cadre / Frame / Chasis

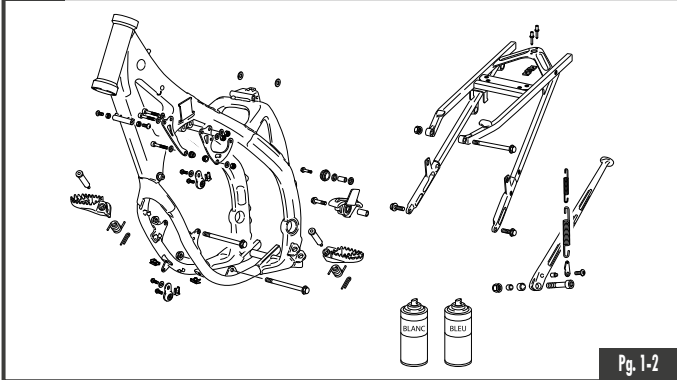

Pg. 1-2

2 Fourche WP XPLOR / Fork WP XPLOR / Horquilla WP XPLOR

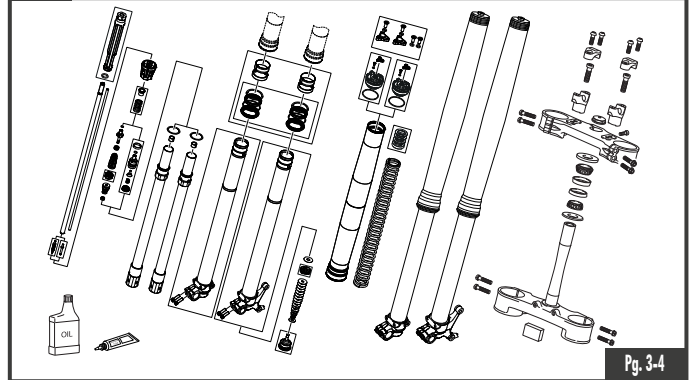

Pg. 3-4

3 Amortisseur - Bras oscillant / Rear Shock - Swingarm / Amortiguador - Basculante

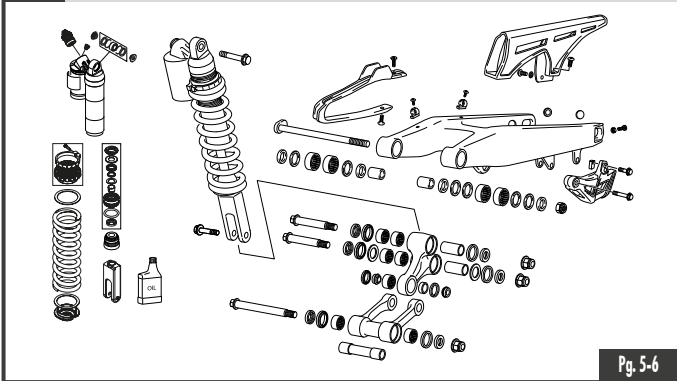

Pg. 5-6

4 Frein arrière / Rear brake / Freno trasero

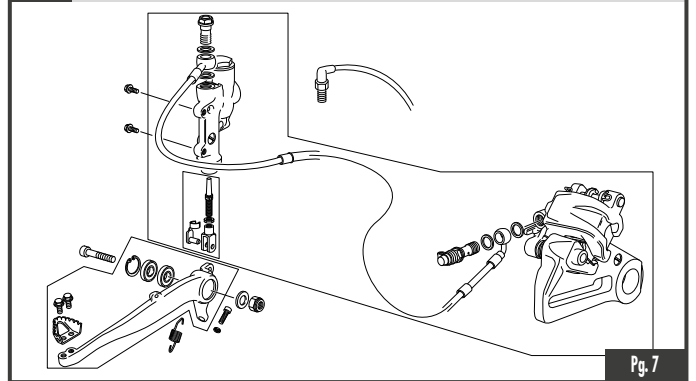

Pg. 7

5 Boîte filtre - échappement / Air filter box - exhaust system / Caja filtro - escape

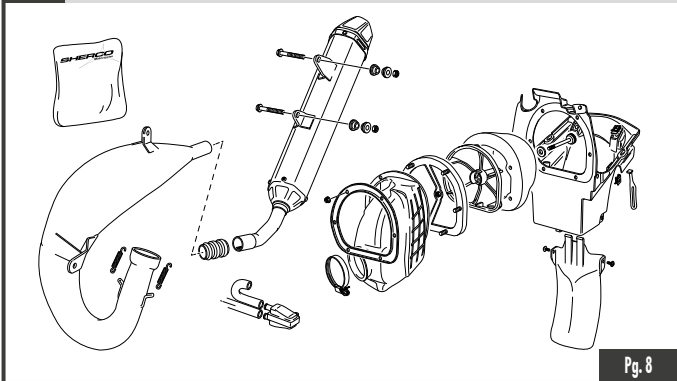

Pg. 8

6 Etrier frein arrière-avant / Front rear caliper / Pinzas freno trasero - delantero

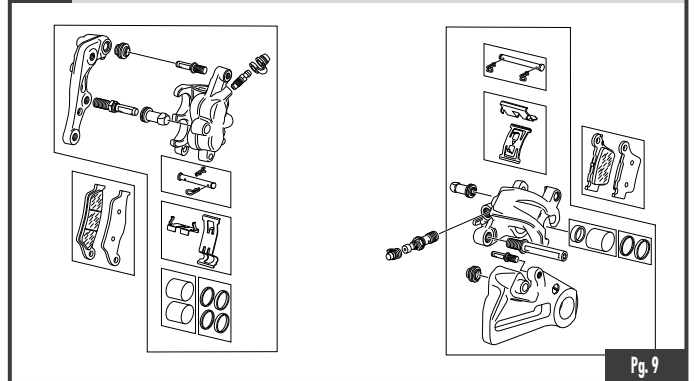

Pg. 9

7 Maître cylindre frein avant - arrière / Master cylinder Front rear caliper / Bomba freno trasero - delantero

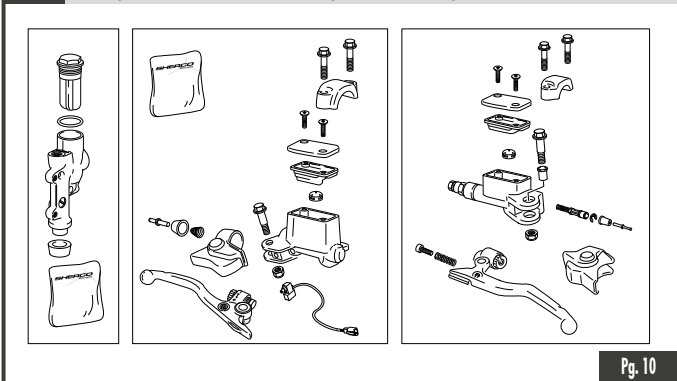

Pg. 10

8 Radiateur / Radiator / Radiador

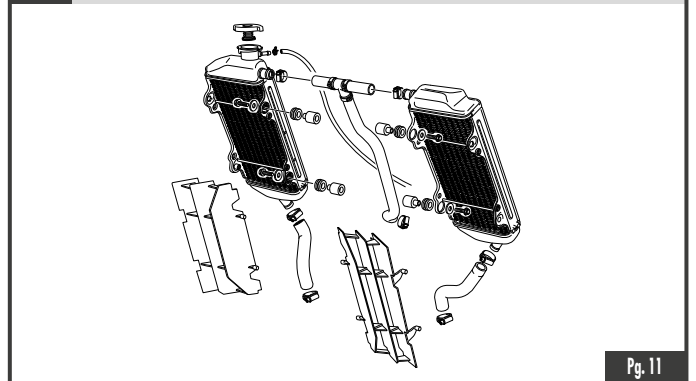

Pg. 11

9 Faisceau électrique / Electrical system / Instalación eléctrica

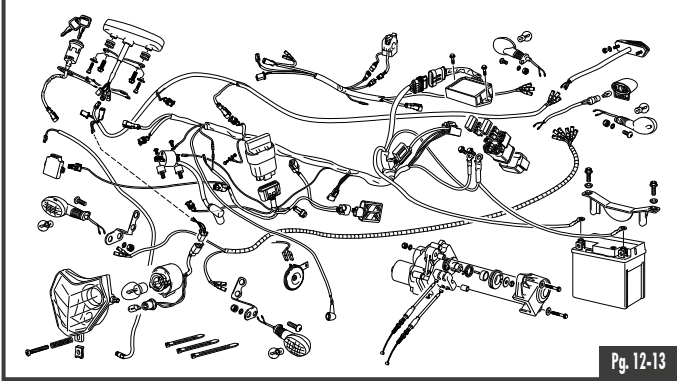

10 Roue avant / Front wheel / Rueda delantera

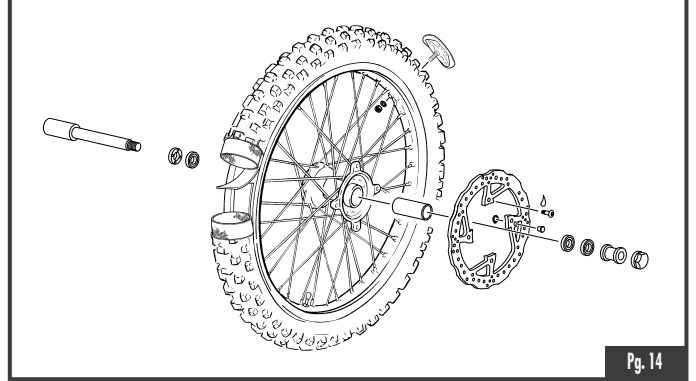

11 Roue arrière / Rear wheel / Rueda trasera

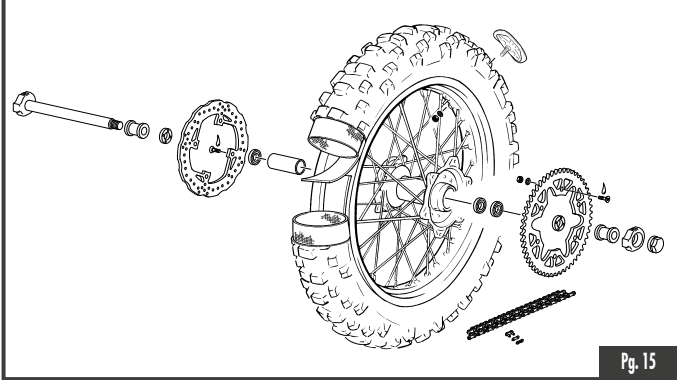

12 Guidon / Handlebar / Manillar

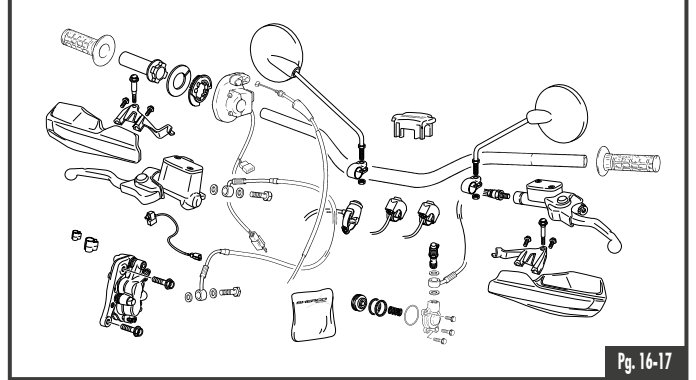

13 Plastiques / Plastics / Plásticos

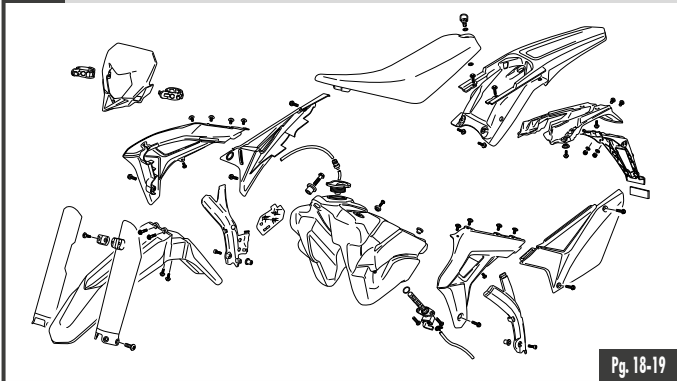

14 Adhésif / Sticker / Adhesivo

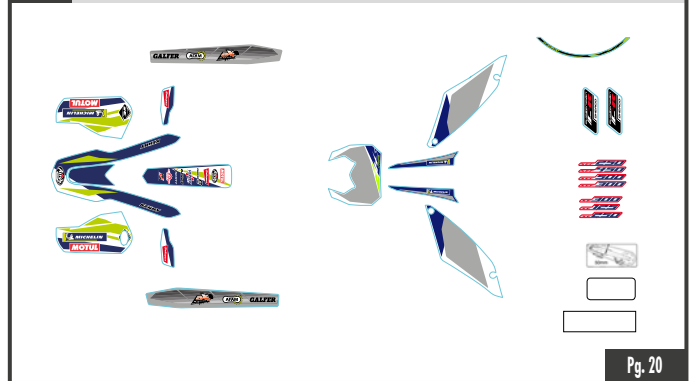

15 Démarreur / Starter motor / Motor de arranque

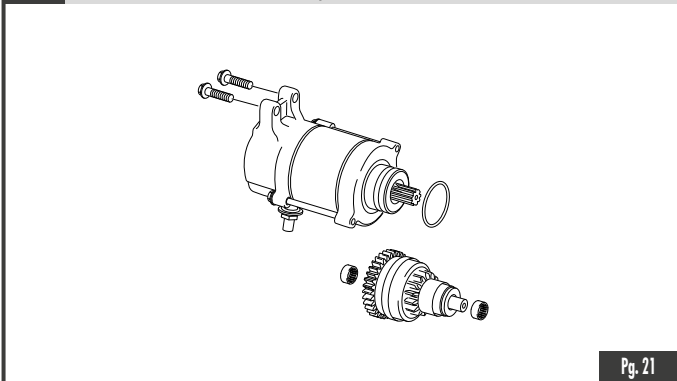

16 Selecteur / Gear selector group / Selector cambio

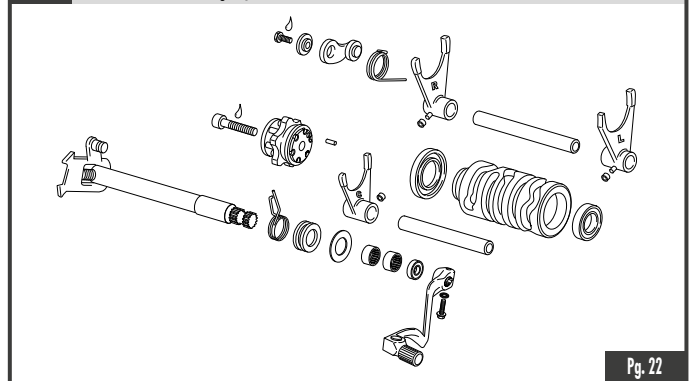

17 Boîte à vitesses / Gear set / Cambio

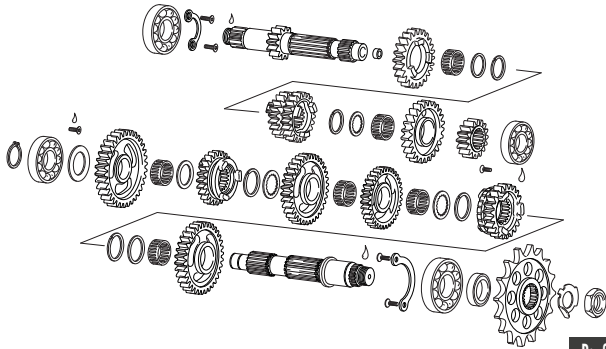

Pg. 23-24

18 Groupe carters / Crankcase assembly / Grupo carter

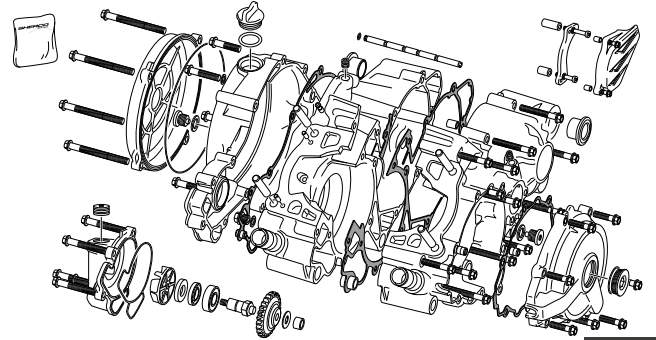

Pg. 25-26

19 vilebrequin assemblé / Crankshaft assembly / Cigüeñal biela

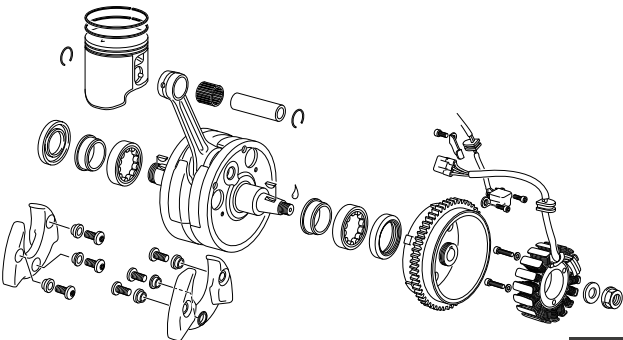

Pg. 27

20 Embrayage / Clutch / Embrague

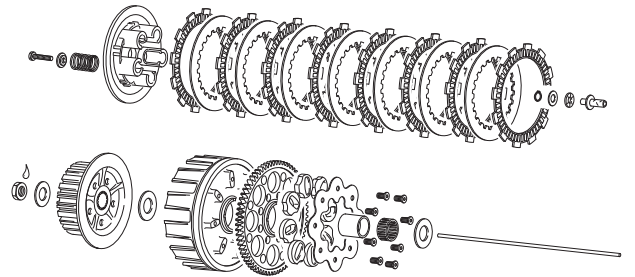

Pg. 28

21 Cylindre-Culasse / Cylinder-Cylinder head / Cilindro-Culata

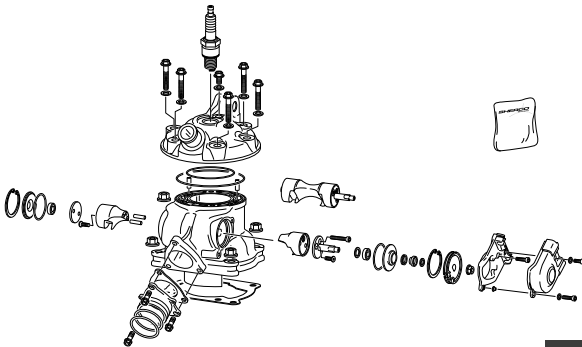

Pg. 29-30

22 Boîte à clapet / Reed valve / Caja de láminas

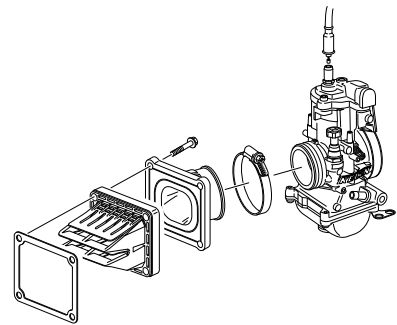

Pg. 31

23 Carburateur / Carburetor / Carburador KEIHIN PWK 36

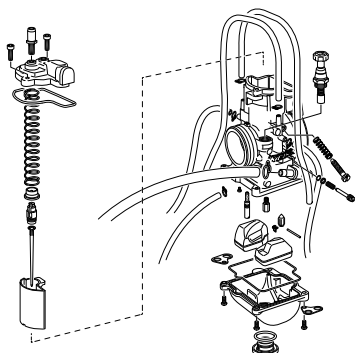

Pg. 32-33

24 Outillage / Tools / Utilajes

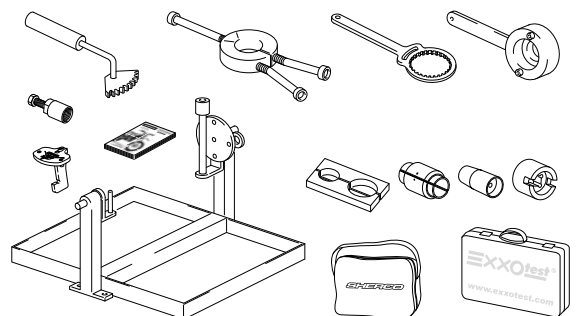

Pg. 34

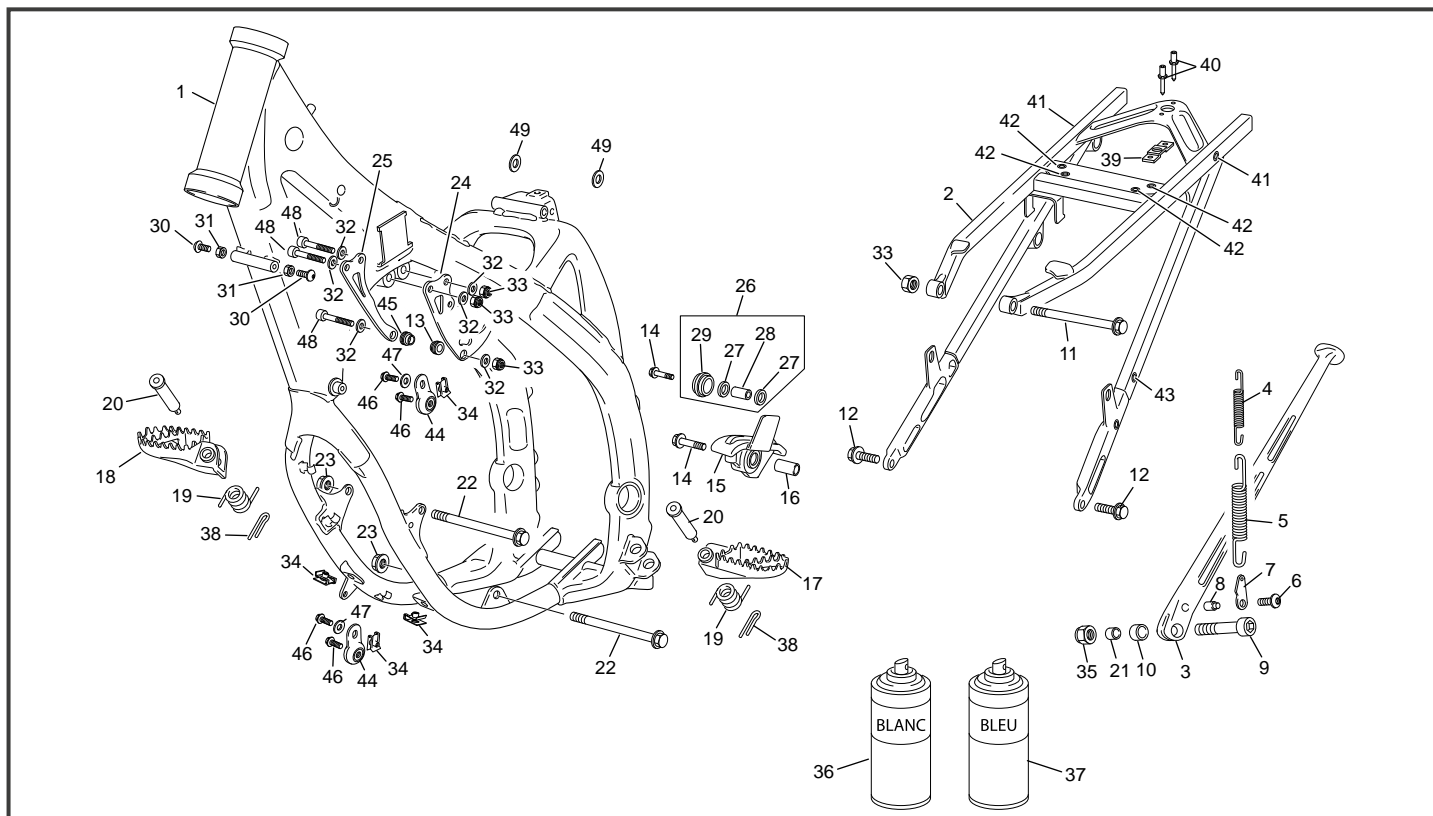

POS.	125 SE-R	FRANÇAIS	ENGLISH	ESPAÑOL
1	7845	CADRE PEINT 125 SE BLEU	CADRE PEINT 125 SE BLEU	CADRE PEINT 125 SE BLEU
2	7292	BERCEAU ARRIERE SE	BERCEAU ARRIERE SE	BERCEAU ARRIERE SE
3	3348	BEQUILLE END 2012	BEQUILLE END 2012	BEQUILLE END 2012
4	3086	RESSORT DE BEQUILLE INT END 2011	RESSORT DE BEQUILLE INT END 2011	RESSORT DE BEQUILLE INT END 2011
5	3085	RESSORT BEQUILLE EXT END 2011	RESSORT BEQUILLE EXT END 2011	RESSORT BEQUILLE EXT END 2011
6	M258	VIS BHC 5 X 16 1093 ZN NI TR	VIS BHC 5 X 16 1093 ZN NI TR	VIS BHC 5 X 16 1093 ZN NI TR
7	3087	PLAQUE MAINTIEN RESSORT BEQUILLE END 2012	PLAQUE MAINTIEN RESSORT BEQUILLE END 2012	PLAQUE MAINTIEN RESSORT BEQUILLE END 2012
8	3450	ENTRETOISE CAME HOMOLOGATION BEQUILLE END	ENTRETOISE CAME HOMOLOGATION BEQUILLE END	ENTRETOISE CAME HOMOLOGATION BEQUILLE END
9	3478	VIS CHC M10 X 40 TETE BASSE ZI BLANC END 2012	VIS CHC M10 X 40 TETE BASSE ZI BLANC END 2012	VIS CHC M10 X 40 TETE BASSE ZI BLANC END 2012
10	3089	ENTRETOISE RESSORT BEQUILLE END	ENTRETOISE RESSORT BEQUILLE END	ENTRETOISE RESSORT BEQUILLE END
11	4825	VIS CHC M8 X 120 DIN 912 8.8 ZI BLANC	VIS CHC M8 X 120 DIN 912 8.8 ZI BLANC	VIS CHC M8 X 120 DIN 912 8.8 ZI BLANC
12	3363	VIS TH EP M8 X 20	VIS TH EP M8 X 20	VIS TH EP M8 X 20
13	6901	ENTRETOISE TIRANT DE CULASSE GAUCHE	ENTRETOISE TIRANT DE CULASSE GAUCHE	ENTRETOISE TIRANT DE CULASSE GAUCHE
14	0578	VIS TH EP M8 X 30	VIS TH EP M8 X 30	VIS TH EP M8 X 30
15	3078	PATIN DE CHAINE AVANT INFERIEUR END 2012	PATIN DE CHAINE AVANT INFERIEUR END 2012	PATIN DE CHAINE AVANT INFERIEUR END 2012
16	3479	DOUILLE PATIN CHAINE END 2012	DOUILLE PATIN CHAINE END 2012	DOUILLE PATIN CHAINE END 2012
17	0227	REPOSE PIED GAUCHE END	REPOSE PIED GAUCHE END	REPOSE PIED GAUCHE END
18	0226	REPOSE PIED DROIT END	REPOSE PIED DROIT END	REPOSE PIED DROIT END
19	0229	RESSORT REPOSE PIED END	RESSORT REPOSE PIED END	RESSORT REPOSE PIED END
20	6482	AXE REPOSE PIED END	AXE REPOSE PIED END	AXE REPOSE PIED END
21	0516	ENTRETOISE INT BEQUILLE 450 / 500 END	ENTRETOISE INT BEQUILLE 450 / 500 END	ENTRETOISE INT BEQUILLE 450 / 500 END
22	1672	AXE MOTEUR 10 X 135	AXE MOTEUR 10 X 135	AXE MOTEUR 10 X 135
23	0703	ECROU NYLSTOP M10 EPAULE DIN 6926	ECROU NYLSTOP M10 EPAULE DIN 6926	ECROU NYLSTOP M10 EPAULE DIN 6926
24	8639	SUPPORT CULASSE GAUCHE SE 125 EVO	SUPPORT CULASSE GAUCHE SE 125 EVO	SUPPORT CULASSE GAUCHE SE 125 EVO
25	6866	SUPPORT CULASSE DROIT 125 SE	SUPPORT CULASSE DROIT 125 SE	SUPPORT CULASSE DROIT 125 SE
26	5549	GALET DE CHAINE END COMPLET	GALET DE CHAINE END COMPLET	GALET DE CHAINE END COMPLET
27	M027	ROULEMENT À BILLE 608.2RSH	ROULEMENT À BILLE 608.2RSH	ROULEMENT À BILLE 608.2RSH
28	0556	DOUILLE GALET CHAINE END 450	DOUILLE GALET CHAINE END 450	DOUILLE GALET CHAINE END 450
29	0231	GALET DE CHAINE END	GALET DE CHAINE END	GALET DE CHAINE END
30	M280	VIS BHC 8 X 16 ZN NI TR PRE IMPREGNEE FAIBLE	VIS BHC 8 X 16 ZN NI TR PRE IMPREGNEE FAIBLE	VIS BHC 8 X 16 ZN NI TR PRE IMPREGNEE FAIBLE
31	3481	ECROU BAS M8 ZI BLANC	ECROU BAS M8 ZI BLANC	ECROU BAS M8 ZI BLANC
32	C430	RONDELLE M8	RONDELLE M8	RONDELLE M8
33	M305	ECROU NYLSTOP M8 0368.8	ECROU NYLSTOP M8 0368.8	ECROU NYLSTOP M8 0368.8
34	M308	ECROU CLIP M6 0500500400	ECROU CLIP M6 0500500400	ECROU CLIP M6 0500500400
35	M304	ECROU NYLSTOP M10 0368.10	ECROU NYLSTOP M10 0368.10	ECROU NYLSTOP M10 0368.10

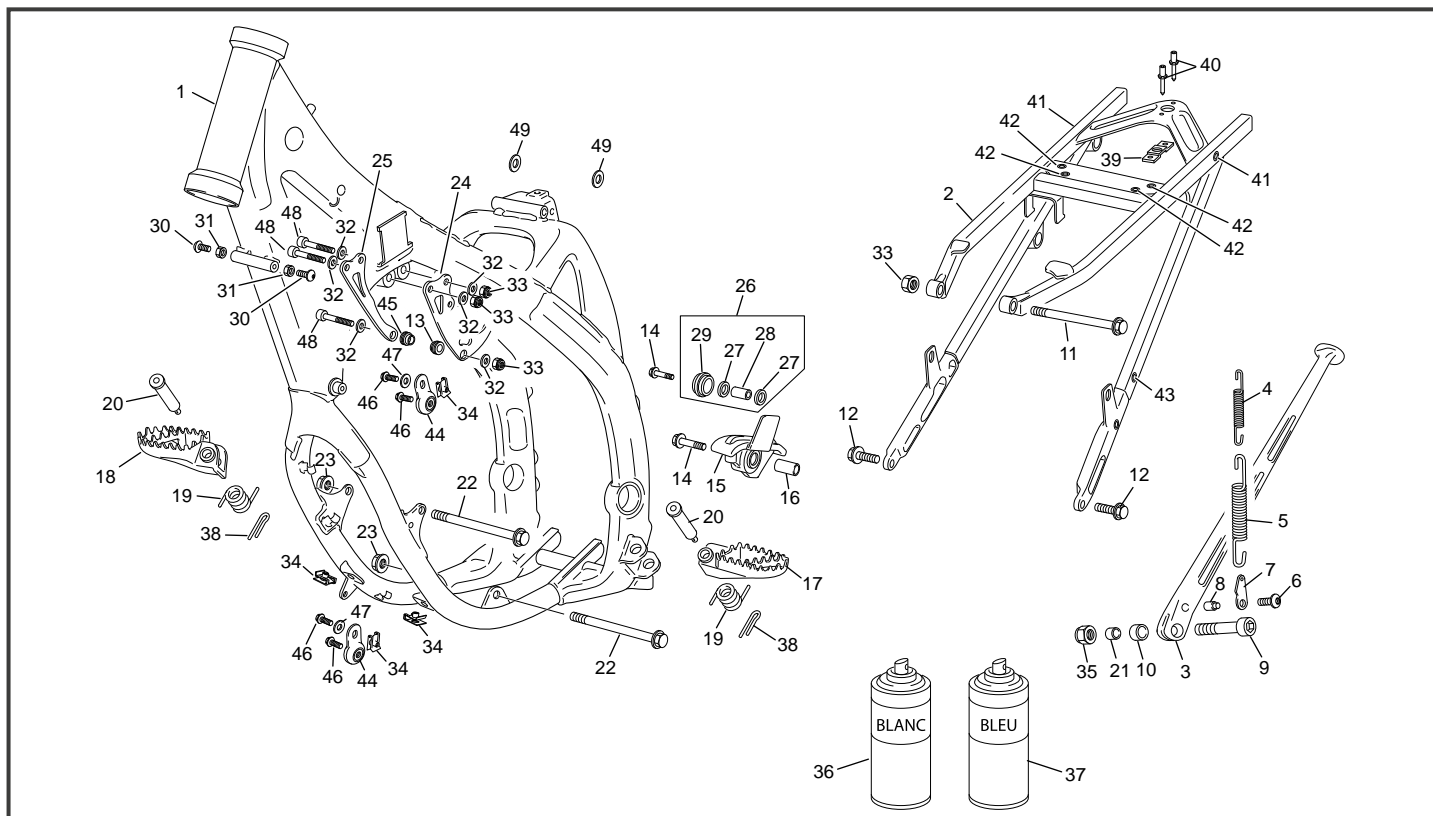

POS.	125 SE-R	FRANÇAIS	ENGLISH	ESPAÑOL
36	3898	BOMBE DE PEINTURE RETOUCHE BLANC 250 END	BOMBE DE PEINTURE RETOUCHE BLANC 250 END	BOMBE DE PEINTURE RETOUCHE BLANC 250 END
37	3897	BOMBE DE PEINTURE RETOUCHE BLEU COBALT 250 END	BOMBE DE PEINTURE RETOUCHE BLEU COBALT 250 END	BOMBE DE PEINTURE RETOUCHE BLEU COBALT 250 END
38	0240	GOUILLE AXE REPOSE PIED END	GOUILLE AXE REPOSE PIED END	GOUILLE AXE REPOSE PIED END
39	6681	PLAQUE DZUS D8	PLAQUE DZUS D8	PLAQUE DZUS D8
40	0701	RIVET ZEBRA 3 X 10	RIVET ZEBRA 3 X 10	RIVET ZEBRA 3 X 10
41	1250	INSERT ECROUS 50 125 06	INSERT ECROUS 50 125 06	INSERT ECROUS 50 125 06
42	4772	INSERT RIVETE M6 FRAISE	INSERT RIVETE M6 FRAISE	INSERT RIVETE M6 FRAISE
43	4773	INSERT RIVETE M5	INSERT RIVETE M5	INSERT RIVETE M5
44	4267	SILENT BLOC POT ECHAPPEMENT 250 2T END	SILENT BLOC POT ECHAPPEMENT 250 2T END	SILENT BLOC POT ECHAPPEMENT 250 2T END
45	6902	ENTRETOISE TIRANT DE CULASSE DROITE	ENTRETOISE TIRANT DE CULASSE DROITE	ENTRETOISE TIRANT DE CULASSE DROITE
46	0546	VIS TH EP 6 X 20	VIS TH EP 6 X 20	VIS TH EP 6 X 20
47	C427	RONDELLE M6 X 15	RONDELLE M6 X 15	RONDELLE M6 X 15
48	M264	VIS CHC 8 X 45 0084 ZN NI TR	VIS CHC 8 X 45 0084 ZN NI TR	VIS CHC 8 X 45 0084 ZN NI TR
49	7617	RONDELLE Ø10.5 X 20 X 1	RONDELLE Ø10.5 X 20 X 1	RONDELLE Ø10.5 X 20 X 1

Fourche WP XPLOR Fork WP XPLOR / Horquilla WP XPLOR

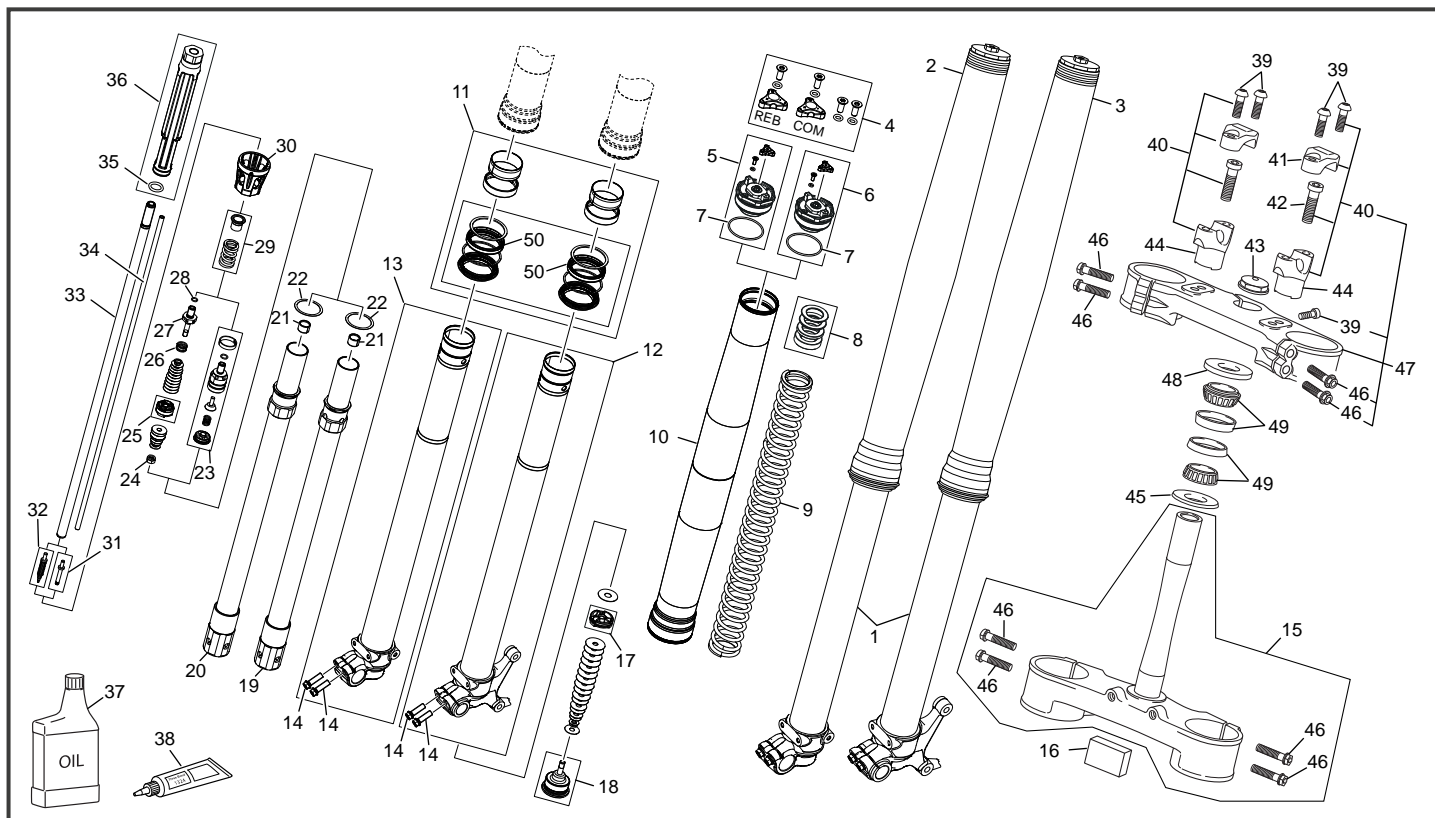

POS.	125 SE-R	FRANÇAIS	ENGLISH	ESPAÑOL
1	6912	FOURCHE SHERCO / WP END 125 XPLOR	XPLOR FORK 125	HORQUILLA SHERCO / WP 125 XPLOR
2	7217	JAMBE FOURCHE DROITE 125 XPLOR	RIGHT FORK LEG WP 125 XPLOR	GAMBA HORQUILLA DER WP 125 XPLOR
3	7216	JAMBE FOURCHE GAUCHE CPL WP 125 XPLOR	LEFT FORK LEG WP 125 XPLOR	GAMBA HORQUILLA IZQUIR 125 XPLOR
4	6835	VIS DE REGLAGE COMP DETENTE	ADJUSTMENT SCREW COM REB	TORNILLO COMP DETENTE
5	6833	BOUCHON FOURCHE XPLOR PRE CHARGE DROIT	RIGHT SCREW CAP SPRING ADJUSTABLE XPLOR	XPLOR IZQUIERDA HORQUILLA AJUSTABLE DER.
6	7626	BOUCHON FOURCHE XPLOR GAUCHE	LEFT FORK CAP	XPLOR IZQUIERDA HORQUILLA IZQUIERDA
7	6836	O-RING 46X2 NBR	O-RING 46X2 NBR	O-RING 46X2 NBR
8	6837	RESSORT ENTRETOISE	SPACER SPRING	MUELES CASQUILLO
9	7066	RESSORT 3.8 N/MM 65-75 KG	SPRING 3,8 N/MM 65-75 KG	MUELLE 3,8 N/MM 65-75 KG
9	7065	RESSORT STD 4.0 N/MM 75-85 KG	SPRING 4,0 N/MM 75-85 KG	MUELLE 4,0 N/MM 75-85 KG
9	6838	RESSORT 4.2 N/MM 85-95 KG	SPRING 4,2 N/MM 85-95 KG	MUELLE 4,2 N/MM 85-95 KG
10	6842	TUBE EXTERIEUR XPLOR	OUTER TUBE	TUBO EXTERNO XPLOR
11	6871	KIT REPARATION FOURCHE WP	REPAIR KIT	KIT REPARACION HORQUILLA WP
12	6872	TUBE DE FOURCHE GAUCHE COMPLET	LEFT AXLE CLAMP + COMPLETE TUBE	GRUPO TUBO IZQUIERDO
13	6873	TUBE DE FOURCHE DROITE COMPLET	RIGHT AXLE CLAMP + COMPLETE TUBE	GRUPO TUBO DERECHO
14	6874	VIS M8X25	SCREW M8X25	TORNILLO M8X25
15	7607	T FOURCHE INF COMPLET RACING SEF SE 2019	VENTIL NUT	PLATINA INF HORQUILLA RACING END 2019
16	3924	ADHESIF GUIDE DURITE END 12	CONICAL SPRING	AD. PATIN TUBOS END 12
17	6875	PISTON COMPRESSION	COMPRESSION PISTON	GRUPO TUBO DERECHO
18	6876	BOUCHON COMPLET	COMPLETE CAP	GRUPO TUBO DERECHO
19	6877	TUBE INTERNE GAUCHE	LEFT INTERNAL TUBE	GRUPO TUBO INTRNO IZQUIERDA
20	6878	TUBE INTERNE DROIT	RIGHT INTERNAL TUBE	GRUPO TUBO INTRNO DERECHA
21	6937	ENTRETOISE GUIDAGE	GUIDING SPACER	GUÍA DE SEPARADOR
22	6938	RONDELLE 27,5X33X0,3	SPACER SHEET 27,5X33X0,3	ARRANDELA 27,5X33X0,3
23	6939	GRUPE COMPRESSION	CPL COMPRESSION GRUP	GRUPO DE COMPRESIÓN
24	6940	ECROU	NUT	GRUPO DE COMPRESIÓN
25	6941	PISTON COMPLET	COMPLETE PISTON	PISTON JUEGO
26	6942	RESSORT CONIQUE	CONICAL SPRING	MUELLES CONICO
27	6943	BOUCHON DETENTE	REBOND CAP	TAPÓN DE DESCANSO
28	6944	O-RING 6X1,2 NBR	O-RING 6X1,2 NBR	O-RING 6X1,2 NBR
29	6945	RESSORT DETENTE	REBOND SPRING	REBOTE MUELLES
30	6946	SUPPORT RESSORT	SPRING SUPPORT	SOPORTE MUELLES
31	6947	AIGUILLE	NEEDLE	AGUJA
32	6948	AIGUILLE	NEEDLE	AGUJA
33	6949	TIGE ALUMINIUM	ALUMINIUM TUBE	BARRA DE ALUMINIO

*Sherco se réserve les droits de modification des références, merci de contrôler sur le portail Sherconetwork avant toute commande. - *Sherco reserves the right to make change on the references, please check on your Sherconetwork portal before ordering.
*Sherco se reserva el derecho para hacer modificaciones sobre las referencias. Por favor, verifica en el Sherconetwork antes de hacer un pedido.

Fourche WP XPLOR Fork WP XPLOR / Horquilla WP XPLOR

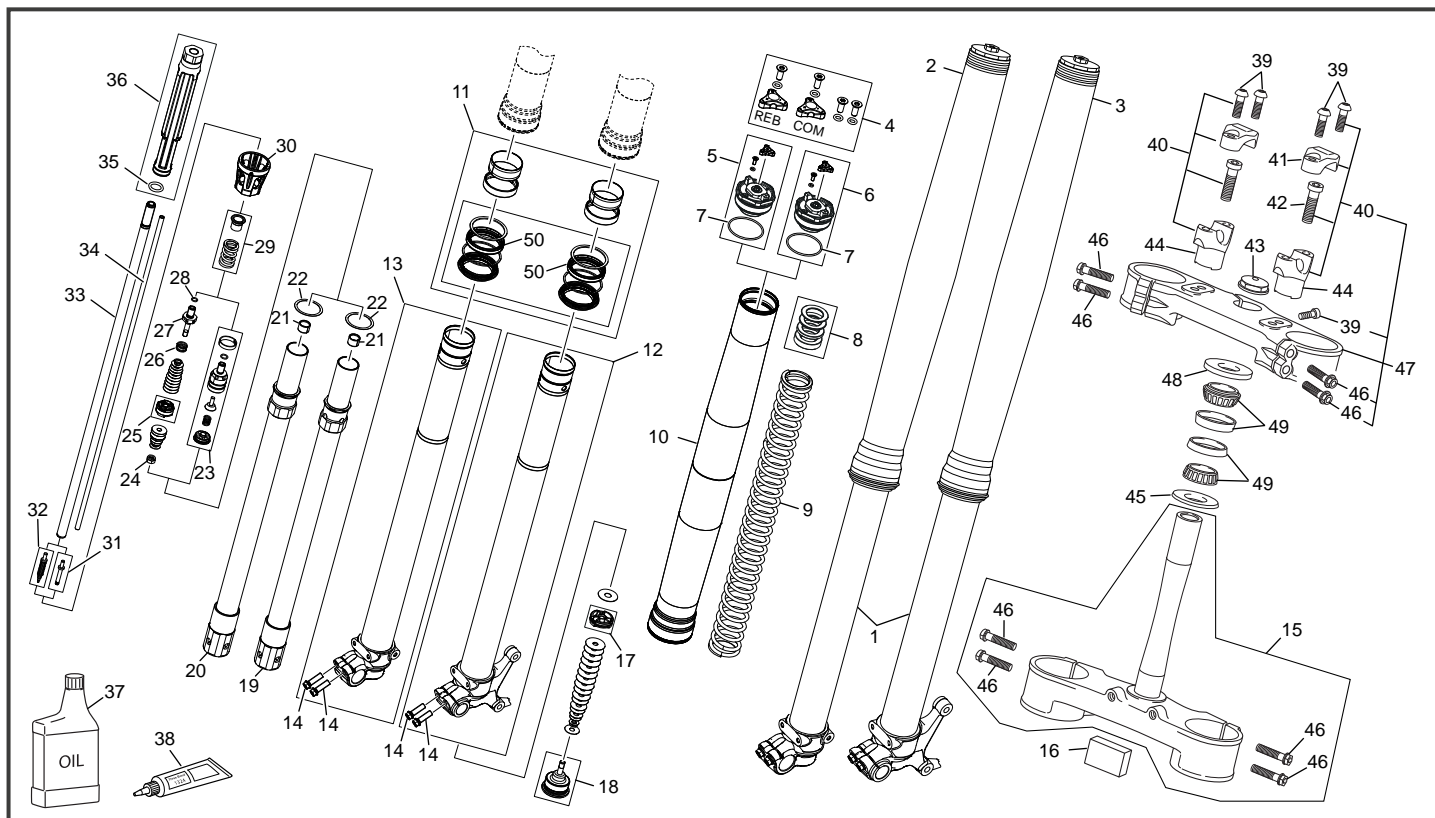

POS.	125 SE-R	FRANÇAIS	ENGLISH	ESPAÑOL
34	6950	TUBE	TUBE	TUBO
35	6951	O RING 11X2,5 NBR	O RING 11X2,5 NBR	O RING 11X2,5 NBR
36	6952	HYDR STOP	HYDR STOP	HYDR STOP
37	4684	HUILE SAE 4 FOURCHE WP 5L	FORK OIL SAE 4	OIL SAE 4 HORQUILLA WP 5L
38	3684	GRAISSE SILICONE FOURCHE WP	SILICON GREASE	SILICONE GRASA HORQUILLA
39	6874	VIS M8 X25	SCREW M8X25	TORNILLO M8 X25
40	8597	BRIDE GUIDON COMPLETE 42.5	HANDLEBAR CLAMPS H=42,5MM	BRIDA INF MANILLAR JUEGO SE SEF 42.5
41	3256	BRIDE GUIDON SUPERIEURE END	UPPER "HANDLEBAR CLAMP"	BRIDA SUPERIOR MANILLAR END
42	3255	VIS CHC M10 X35 NEKEN	SCREW CHC M10X35	TORNILLO CHC M10 X35 NEKEN
43	0460	ECROU PIVOT DIRECTION END 450	NUT	TUERCA EJE DIRECCION END 450
44	3257	BRIDE GUIDON INFERIEURE 42.5 END 2011	LOWER HANDLEBAR 42,5MM	BRIDA INFERIOR 42.5 MANILLARD END 2011
44	3258	BRIDE GUIDON INFERIEURE 50 MM END 2011	LOWER HANDLEBAR 50MM	BRIDA INFERIOR 50MM MANILLARD END 2011
44	3259	BRIDE GUIDON INFERIEURE 57.5 MM END 2011	LOWER HANDLEBAR 57,5MM	BRIDA INFERIOR 57.5MM MANILLARD END 2011
45	7607	JOINT DIRECTION INF END 450	SEAL	JUNTA DIRECCION INF END
46	8397	VIS TH EP M8 X 35 TORX	VIS TH EP M8 X 35 TORX	TORNILLO HEXA M8 X 35 TORX
47	7597	T FOURCHE SUP COMPLET SEF SE RACING	UPPER FORK CLAMP	PLATINA SUP HORQUILLA JUEGO FRACING 2019
48	0354	PROTECTEUR SUP COLONNE DIRECTION END 450	UPPER BEARING CAP	PROTECTOR COJINETE DIRECCION END 450
49	0353	ROULEMENT DIRECTION 320/28X/Q END 450	BEARING	COJINETE DIRECCION 320/28X/Q END 450
50	4379	JOINT SPI FOURCHE WP UNITE	RING FORCK WP UNIT	TORICA SUSPENSION UNIDAD WP

Amortisseur - Bras oscillant Rear Shock - Swingarm / Amortiguador - Basculante

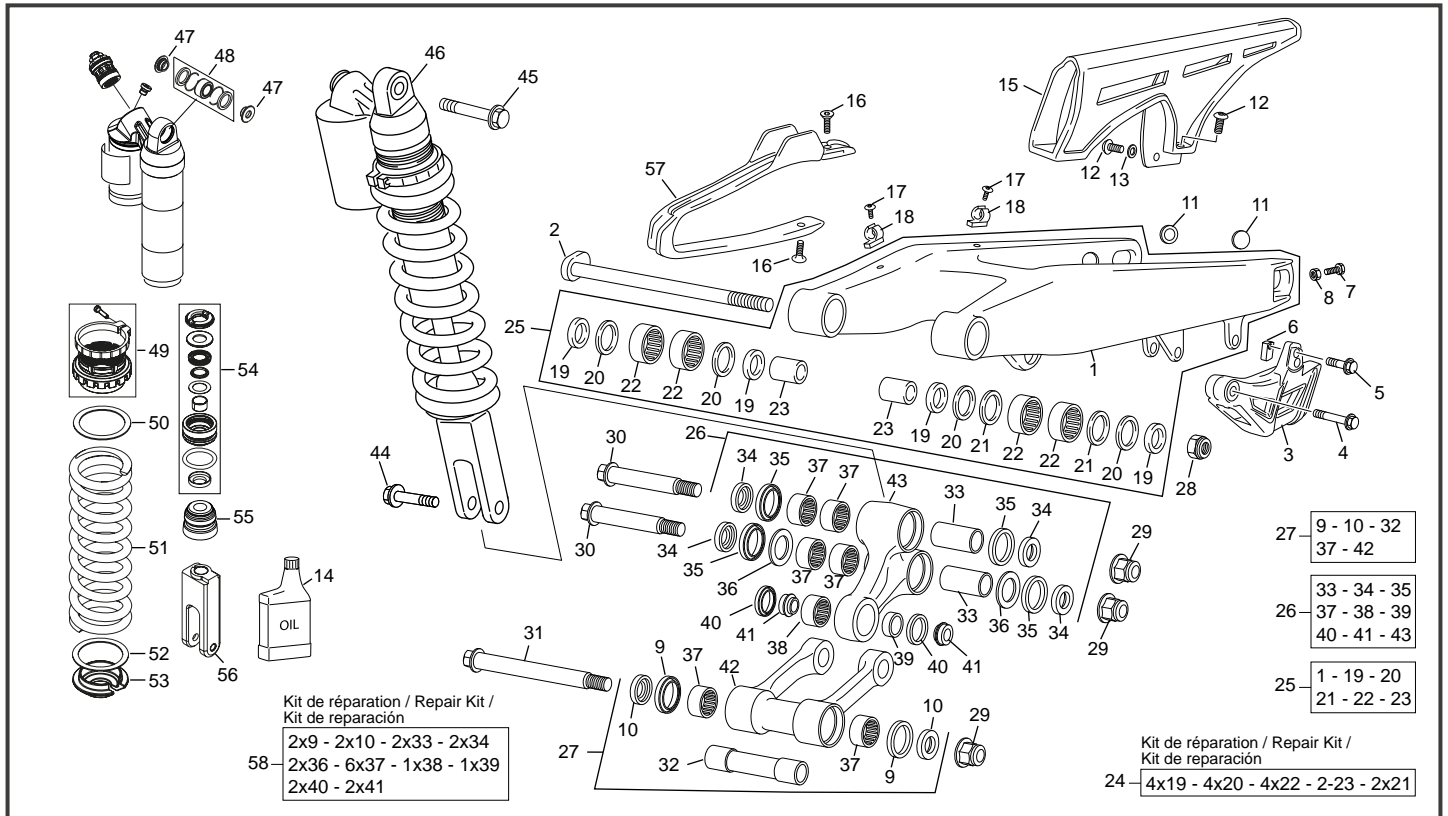

POS.	125 SE-R	FRANÇAIS	ENGLISH	ESPAÑOL
1	8144	BRAS OSCILLANT	BRAS OSCILLANT	BASCULANTE
2	0451	AXE BRAS OSCILLANT	AXE BRAS OSCILLANT	EJE BASCULANTE
3	4533	GUIDE CHAINE EVO BLEU	GUIDE CHAINE EVO BLEU	PATIN CADENA EVO AZUL
4	0549	VIS THEP M6X45	VIS THEP M6X45	TORNILLO THEP M6X45
5	0546	VIS THEP M6X20	VIS THEP M6X20	TORNILLO THEP M6X20
6	2343	ECROU SPECIAL	ECROU SPECIAL	TUERCA ESPECIAL
7	0462	VIS TENDEUR DE CHAINE	VIS TENDEUR DE CHAINE	TORNILLO TENSOR CADENA
8	M272	ECROU EMBASE M8	ECROU EMBASE M8	TUERCA CON VALONA M8
9	6493	JOINT À LÈVRES	JOINT À LÈVRES	RETEN
10	8137	ENTRETOISE	ENTRETOISE	DISTANCIAL
11	1103	BOUCHON BRAS OSCILLANT	BOUCHON BRAS OSCILLANT	TAPA BASCULANTE
12	M283	VIS BHC M6X16	VIS BHC M6X16	TORNILLO BHC M6X16
13	C427	RONDELLE M6X15	RONDELLE M6X15	ARANDELA M6X15
14	3694	HUILE AMORTISSEUR	HUILE AMORTISSEUR	ACEITE DEL AMORTIGUADOR
15	0298	CARTER DE CHAINE	CARTER DE CHAINE	PROTECTOR CADENA
16	C432	VIS FHC M6X16	VIS FHC M6X16	TORNILLO FHC M6X16
17	M278	VIS BHC M6X20	VIS BHC M6X20	TORNILLO BHC M6X20
18	0307	GUIDE DURITE FREIN AR	GUIDE DURITE FREIN AR	SOPORTE TUBO FRENO
19	0440	ENTRETOISE ETANCHEITE BRAS	ENTRETOISE ETANCHEITE BRAS	CAS. ESTANQUEIDAD DEL BASCULANTE
20	0292	JOINT A LEVRES 28X35X4	JOINT A LEVRES 28X35X4	RETÉN 28X35X4
21	0398	RONDELLE	RONDELLE	ARANDELA
22	0290	DOUILLE ALGUILLE	DOUILLE ALGUILLE	CASQUILLO AGUJAS
23	0291	ENTRETOISE AXE BRAS OSCILLANT	ENTRETOISE AXE BRAS OSCILLANT	CASQUILLO EJE DEL BASCULANTE
24	8450	KIT REFECTION BRAS OSCILLANT	REBUILT KIT SWIGN ARM	KIT DE RECONSTRUCCIÓN BASCULANTE
25	6686	BRAS OSCILLANT ASSEMBLÉ	BRAS OSCILLANT ASSEMBLÉ	BASCULANTE COMPLETO
26	8444	BIELLETTA DELTA ASSEMBLÉE	BIELLETTA DELTA ASSEMBLÉE	BIELETA DELTA COMPLETA
27	8443	BIELLETTA H ASSEMBLÉE	BIELLETTA H ASSEMBLÉE	BIELETA H COMPLETA
28	7506	ECROU NYLSTOP M16	ECROU NYLSTOP M16	TUERCA AUTOBLOC M16
29	0444	ECROU NYLSTOP M12	ECROU NYLSTOP M12	TUERCA AUTOBLOC M12
30	6489	AXE BIELLETTE DELTA 14 MM	AXE BIELLETTE DELTA 14 MM	EJE BIELETA DELTA 14 MM
31	6492	AXE BIELLETTE H 14 MM	AXE BIELLETTE H 14 MM	EJE BIELETA H 14 MM
32	8148	ENTRET. ROULEM. POUR BIELLETTE H	ENTRET. ROULEM. POUR BIELLETTE H	CASQ. RODAMIENTO POR BIELETA H
33	6486	ENTRET. ROULEM. POUR BIELLETTE DELTA	ENTRET. ROULEM. POUR BIELLETTE DELTA	CASQ. RODAMIENTO POR BIELETA DELTA
34	6485	ENTRETOISE POUR BIELLETTE	ENTRETOISE POUR BIELLETTE	CASQ. POR BIELETA
35	8141	JOINT À LÈVRES 25X32X4	JOINT À LÈVRES 25X32X4	RETEN 25X32X4

Amortisseur - Bras oscillant Rear Shock - Swingarm / Amortiguador - Basculante

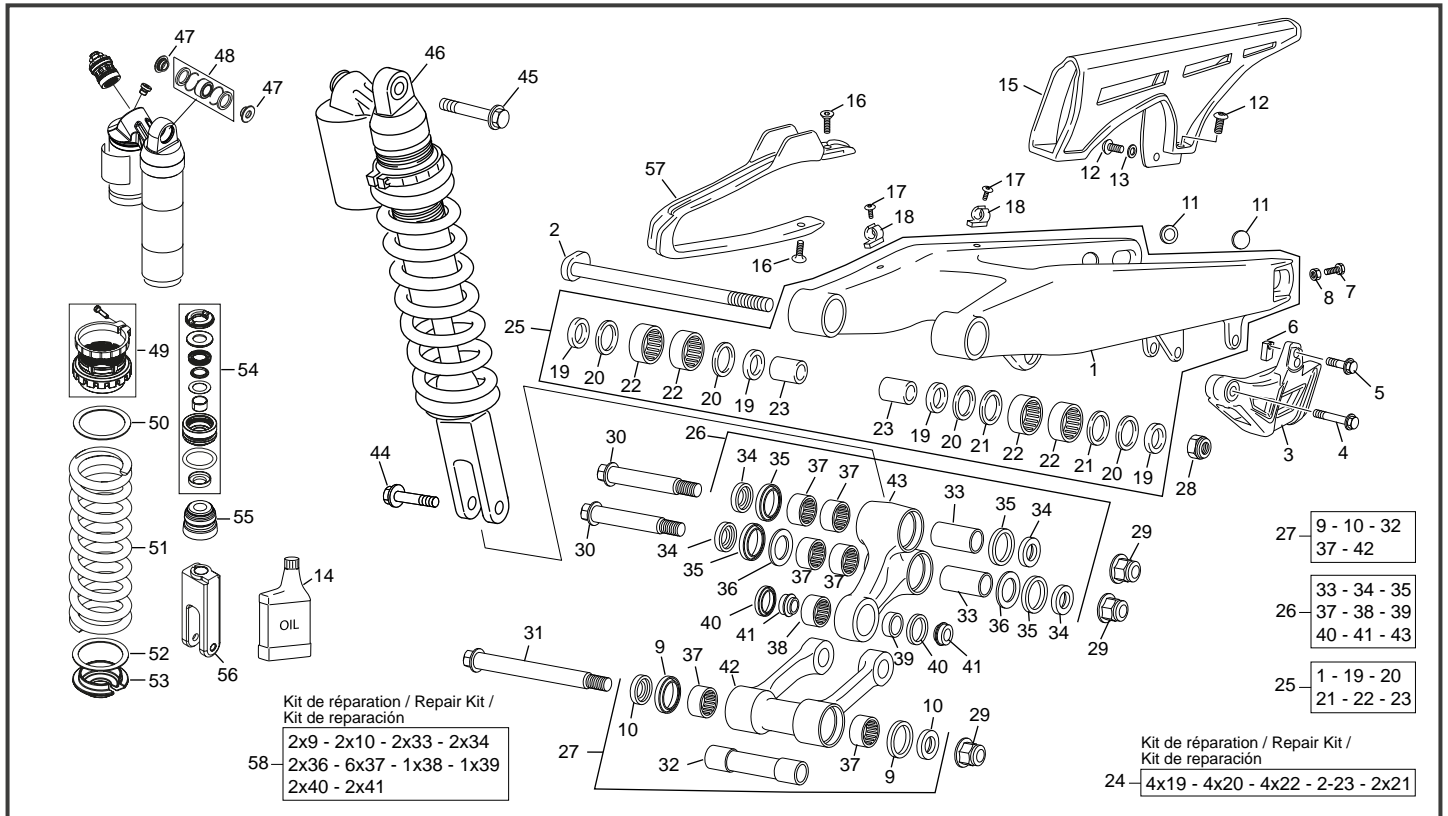

POS.	125 SE-R	FRANÇAIS	ENGLISH	ESPAÑOL
36	6484	RONDELLE SPÉCIAL	RONDELLE SPÉCIAL	SPECIAL WASHER
37	6495	CAGE À AIGUILLE 20X26X16	CAGE À AIGUILLE 20X26X16	RODAMIENTO 20X26X16
38	8139	CAGE À AIGUILLE 20X26X12	CAGE À AIGUILLE 20X26X12	RODAMIENTO 20X26X12
39	8142	ENTRET. ROULEM. POUR BIELLETTE DELTA	ENTRET. ROULEM. POUR BIELLETTE DELTA	CASQUILLO RODAM. BIELETA DELTA
40	8143	JOINT À LÈVRES 18X26X4	JOINT À LÈVRES 18X26X4	RETEN 18X26X4
41	8141	ENTRET. BIELLETTE DELTA PIED AMORT.	ENTRET. BIELLETTE DELTA PIED AMORT.	CASQUILLO BIELETE DELTA AMORT.
42	8138	BIELLETTTE H	BIELLETTTE H	BIELETA H
43	8140	BIELLETTTE DELTA	BIELLETTTE DELTA	BIELETA DELTA
44	0438	AXE AMORTISSEUR INF M10	AXE AMORTISSEUR INF M10	EJE AMORTIGUADOR INF M10
45	0478	AXE AMORTISSEUR SUP M10	AXE AMORTISSEUR SUP M10	EJE AMORTIGUADOR SUP M10
46	6910	AMORTISSEUR 125 SE WP	AMORTISSEUR 125 SE WP	AMORTIGUADOR 125 SE WP
47	6606	ENTRETOISE ROTULE	ENTRETOISE ROTULE	DISTANCIAL ROTULA
48	6605	ROTULE AMORTISSEUR	ROTULE AMORTISSEUR	ROTULA AMORTIGUADOR
49	6608	BAGUE PLASTIQUE	BAGUE PLASTIQUE	ARANDELLA DE PLASTICO
50	3688	RONDELLE RESSORT SUPÉRIEUR	RONDELLE RESSORT SUPÉRIEUR	ARANDELLA DEL MUELLE SUPERIOR
51	6624	RESSORT 48 N/MM (65-75 KG)	RESSORT 48 N/MM (65-75 KG)	MUELLE 48 N/MM (65-75 KG)
51	6625	RESSORT 51 N/MM (75-85 KG)	RESSORT 51 N/MM (75-85 KG)	MUELLE 51 N/MM (75-85 KG)
51	6626	RESSORT 54 N/MM (85-95 KG)	RESSORT 54 N/MM (85-95 KG)	MUELLE 54 N/MM (85-95 KG)
52	6609	RONDELLE RESSORT INFÉRIEUR	RONDELLE RESSORT INFÉRIEUR	ARANDELLA DEL MUELLE INFERIOR
53	3689	RONDELLE DE MAINTIEN RESSORT	RONDELLE DE MAINTIEN RESSORT	SOMBRERERA AMORTIGUADOR
54	6610	KIT DE RÉPARATION	KIT DE RÉPARATION	KIT DE REPARACION
55	6611	TAMPON FIN DE COURSE	TAMPON FIN DE COURSE	GOMA FIN DE CORSA
56	6607	PIED D'AMORTISSEUR	PIED D'AMORTISSEUR	BRIDA HORQUILLA DEL AMORTIGUADOR
57	0297	PATIN DE CHAÎNE	PATIN DE CHAÎNE	PATIN CADENA
58	8451	KIT REFECTION BIELLETTE DELTA ET H 14MM	REBUILT KIT LINKAGE BEARING 14MM	KIT DE RECONSTRUCCIÓN BIELLETTA DELTA Y H 14MM

Frein arrière Rear brake / Freno trasero

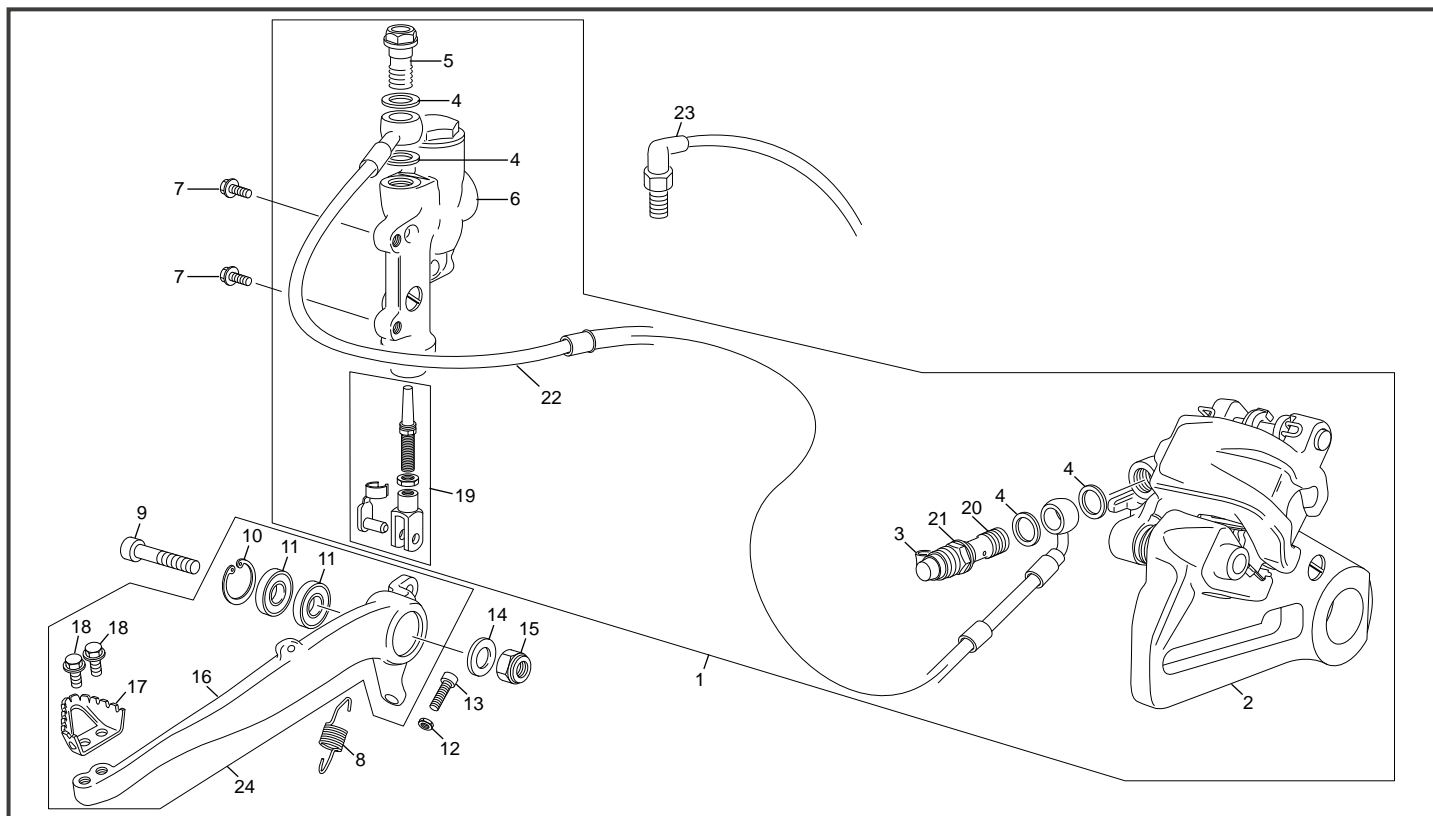

POS.	125 SE-R	FRANÇAIS	ENGLISH	ESPAÑOL
1	8310	GRUPE FREIN AR CPL EURO4 (CONTACTEUR STOP)	REAR BRAKE SYSTEM ASSY EURO4 (SWITCH STOP)	CTO. FRENO TRASERO EURO4 (STOP)
2	3559	ETRIER FREIN AR	REAR CALIPER	PINZA FRENO TRASERA
3	3618	CAPUCHON	CAP	TAPÓN
4	3620	RONDELLE BANJO	BANJO SEAL	ARANDELA BANJO
5	3619	VIS BANJO	BANJO SCREW	TORNILLO BANJO
6	3560	POMPE FREIN AR BREMBO	REAR MASTER CYLINDER BREMBO	BOMBA FRENO TRASERO BREMBO
7	0943	VIS THEP M6X12	SCREW THEP M6X12	TORNILLO THEP M6X12
8	0336	RESSORT PÉDALE FREIN	REAR BRAKE LEVER SPRING	MUELLE PALANCA FRENO
9	2926	VIS PIVOT PÉDALE DE FREIN	SCREW REAR BRAKE PEDAL	TOR. DE LA PALANCA DEL FRENO TRAS.
10	2925	CIRCLIP 26X1,2	CIRCLIP 26X1,2	CIRCLIP 26X1,2
11	2924	ROULEMENT BILLE 26X10X8	BREARING 26X10X8	RODAMIENTO 26X10X8
12	3556	ECROU M6	NUT M6	TUERCA M6
13	C410	VIS CHC M6 X 25	SCREW CHC M6X25	TORNILLO CHC M6X25
14	C424	RONDELLE 200X105X2	WASHER 200X105X2	ARANDELA 200X105X2
15	0703	ECROU EAPULÉ NYLSTOP M10	NUT NYLSTOP M10	TUERCE NYLSTOP M10
16	7196	PÉDALE DE FREIN ARRIÈRE	REAR BRAKE PEDAL	PALANCA FRENO TRASERO
17	2153	EMBOUT PÉDALE FREIN	POINT BREAK PEDAL	PUNTERA PEDAL FRENO
18	0655	VIS THEP M5X10	SCREW THEP M5X10	TORNILLO THEP M5X10
19	3520	KIT CHAPE PÉDALE FREIN BREMBO	BRAKE PEDAL BALANCE BEAM KIT	KIT HORQUILLA PEDAL FRENO BREMBO
20	3640	RACCORD BANJO	BANJO BOLT	TORNILLO BANJO
21	3639	PURGEUR	BLEEDER SCREW	TORNILLO DE PURGA
22	3562	DURITE FREIN ARRIÈRE	REAR BRAKE HOSE	TUBO FRENO TRASERO
23	0625	CONTACTEUR FEUX STOP	BRAKE SWITCH	CONMUTADOR DE FRENO
24	8739	PÉDALE FREIN ALU 125 SE COMPLETE	COMPLETE REAR BRAKE PEDAL 125 SE	PEDAL DE FRENO TRASERO COMPLETA 125 SE

Boîte filtre - échappement Air filter box - exhaust system / Caja filtro - escape

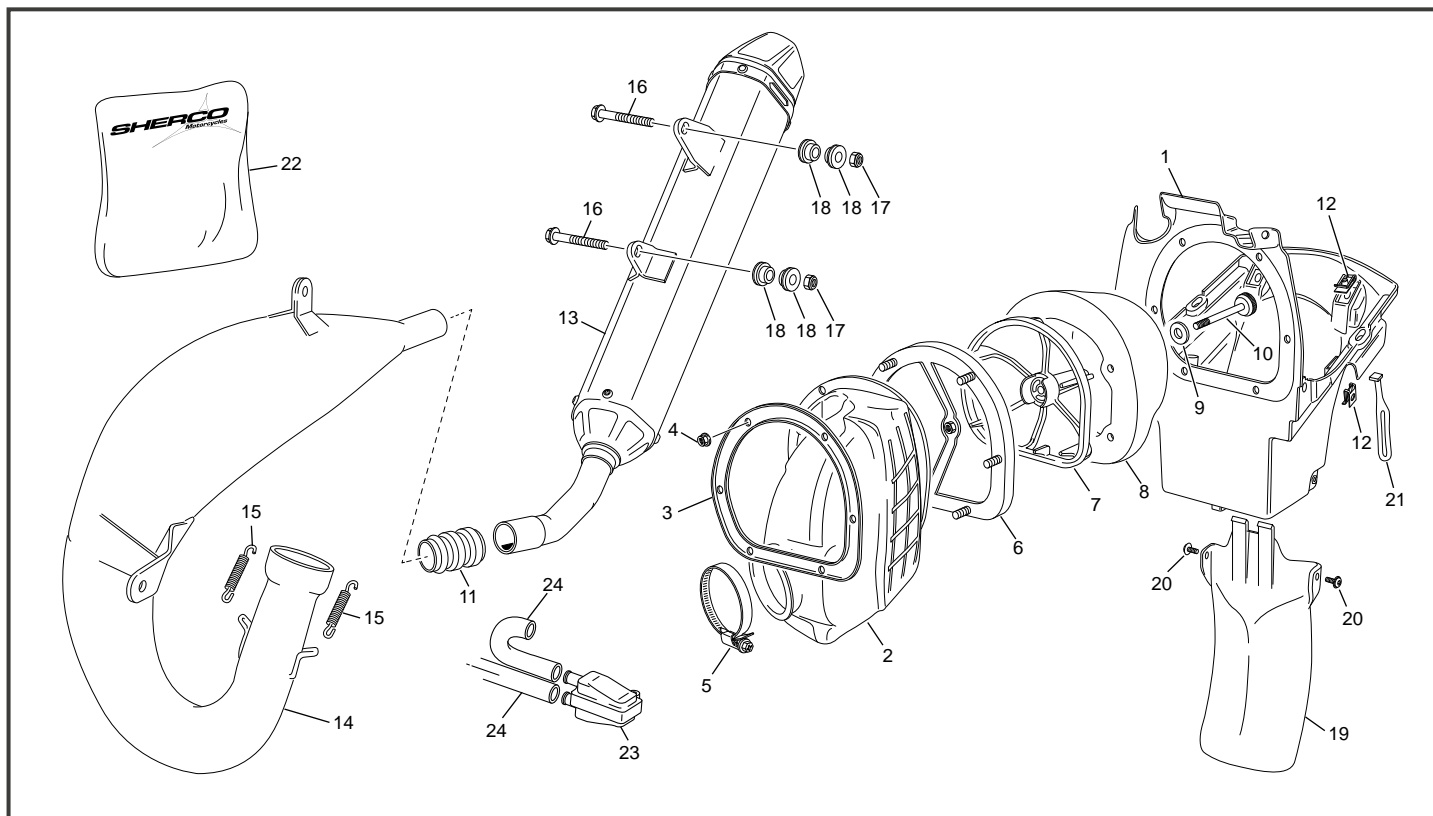

POS.	125 SE-R	FRANÇAIS	ENGLISH	ESPAÑOL
1	3055	BOITIER FILTRE AIR END	AIR BOX END	CAJA FILTRO END
2	4338	MANCHON CAOUTCHOUC	INTAKE HOSE	GOMA INJECTION/CAJA
3	3045	PLAQUE MAINTIEN SUPPORT FILTRE	FIXATION RETAINER PLATE	PLACA FIJACION SOPORTE ESPUMA
4	3552	ECROU EMBASE M5	NUT M5	TUERCA CON VALONA EMBASE M5
5	C415	COLLIER ZEBRA 50 X 70	HOSE CLAMP 50 X 70	ABRAZADERA ZEBRA 50 X 70
6	3046	BRIDE SUPPORT DE FILTRE AIR END 2012	STEEL SUPPORT FILTER RETAINER	BRIDA PLACA FIJACION SOPORTE ESPUMA
7	3044	SUPPORT MOUSSE FILTRE END 2012	AIR FILTER RETAINER	SUPORTE ESPUMA FILTRO END 2012
8	4509	MOUSSE FILTRE END 250/300 2T	AIR FILTER 2 STROKES	ESPUMA FILTRO END 250/300 2T
9	C429	RONDELLE M6 X 25	WASHER M6 X 25	ARANDELA M6 X 25
10	3048	VIS DE FILTRE AIR END EVO	SCREW AIR FILTER MOUNTING	TORNILLO ESPUMA FILTRE END EVO
11	7129	MANCHON RACCORD ECHAPPEMENT	RUBBER HOSE EXHAUST	GOMA ESCAPE END 125 SE
12	M308	ECROU CLIP M6 0500500400	NUT CLIP M6	TUERCA CLIP M6
13	7283	SILENCIEUX 125 SE RACING	SILENCER 125 SE RACING	SILENCOSO 125 SE RACING
14	5909	ECHAPPEMENT RACING 125 SE	EXHAUST RACING 125 SE	ESCAPE RACING 125 SE
15	0271	RESSORT POT END 450	EXHAUST SPRING END 450	MUELLE ESCAPE END 450
16	0548	VIS TH EP 6 X 35	TH EP SCREW 6 X 35	TORNILLO TH EP 6 X35
17	M306	ECROU NYLSTOP M6 0368.6	NYLSTOP NUT M6	TUERCA NYLSTOP M6
18	0274	SILENBLOC SILENCIEUX END 450	EXHAUST SILENBLOC END	SILENBLOC SILENCIOSO EN 450
19	3056	BAVETTE DE FILTRE END 250/300 2012	FILTER GUARD END	BAVETTE FILTRO END 250/300 2012
20	1687	VIS BHC EPAULE M5 X 10	BHCE SCREW M5 X 10	TORNILLO ULS CON VALONA M5 X 10
21	0306	CAOUTCHOUC DE MAINTIEN DE BEQUILLE	SIDE STAND RUBBER	GOMA CABALETE END 450
22	7773	KIT RECHARGE SILENCIEUX 125 2T 2019	MUFFLER REPAIR KIT	KIT RECARGA SILENCIOSA 125 2T 2019
23	H377	VALVE AIS	AIS VALVE	VALVULA AIRE PARALELO
24	1037	DURITE VALVE DE POT 610MM	AIS EXAUST TUBE 610MM	TUBOS VALVE AIS 610MM

Etrier frein arrière-avant Front rear caliper / Pinzas freno trasero - delantero

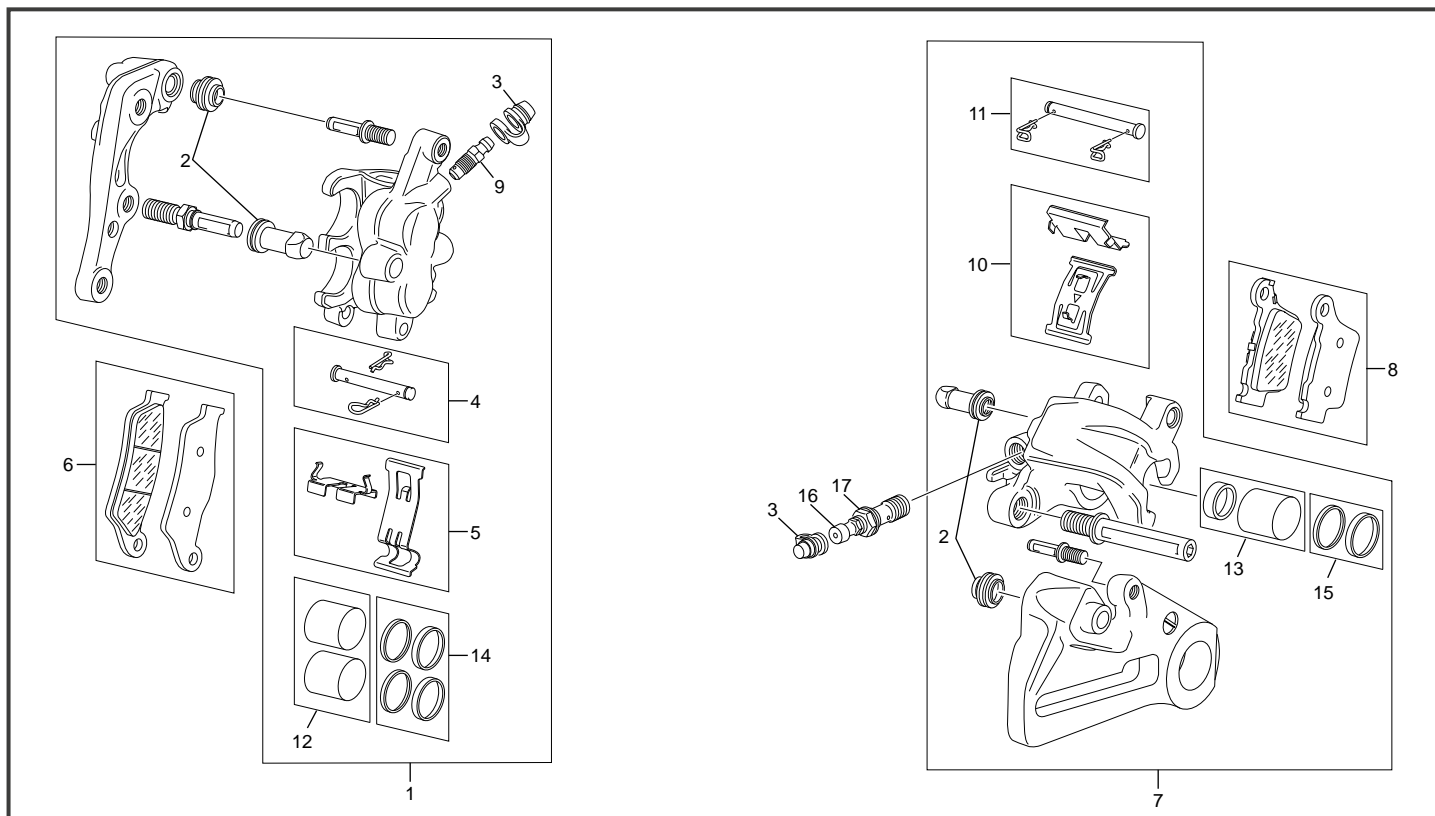

POS.	125 SE-R	FRANÇAIS	ENGLISH	ESPAÑOL
1	3561	ETRIER FREIN AVANT BREMBO	FRONT CALIPER ASSY	PINZA FRENO DELANTERO
2	3706	AXE ET CACHE POUSSIÈRE	CUP SET SHORT	EJE Y PROTECCIÓN DE POLVO
3	3618	CAPUCHON	CAP	TAPÓN
4	3708	AXE DE PLAQUETTE DE FREIN AVANT	BOLT ASSY	EJE PASTILLAS
5	3709	RESS. ANTI VIBRATION DE PLAQ. AVANT	RETAINING PLATE SET	MUELLE TENSION PASTILLAS DELANTERO
6	3710	PLAQUETTE FREIN AVANT BREMBO	BRAKE PADS FRONT	JUEGO PASTILLAS FRENO DELANTERA
7	3559	ETRIER DE FREIN AR BREMBO	REAR CALIPER ASSY	PINZA FRENO TRASERO
8	3711	PLAQUETTE DE FREIN ARRIÈRE	BRAKE PADS REAR	JUEGO PASTILLAS FRENO DETRÁS
9	3707	VIS DE PURGE	BLEEDER SCREW WITH CAP	TORNILLO CONEXIÓN CON TORNILLO
10	3712	RESS. ANTI VIBRATION DE PLAQ. ARRIÈRE	RETAINING SPRING SET	MUELLE TENSION PASTILLAS DETRÁS
11	3713	AXE DE PLAQUETTE DE FREIN ARRIÈRE	BOLT SET FOR REAR BRAKE CALIPER	EJE PASTILLAS
12	4056	PISTONS ETRIER AVANT	FRONT CALIPER PISTONS	PISTONES PINZA DELANTERO
13	4057	PISTONS ETRIER ARRIÈRE	REAR CALIPER PISTONS	PISTONES PINZA TRASERO KIT RETENES
14	4405	JOINTS PISTONS ETRIER AVANT	FRONT CALIPER SEALS	RETENES PINZA DELANTERO
15	4406	JOINTS PISTONS ETRIER ARRIÈRE	REAR CALIPER SEALS	RETENES PINZA TRASERO
16	3639	PURGEUR	BLEEDER SCREW	TORNILLO DE PURGA
17	3640	RACCORD BANJO	BANJO BOLT	TORNILLO BAJO

Maitre cylindre frein avant - arrière Master cylinder Front rear caliper / Bomba freno trasero - delantero

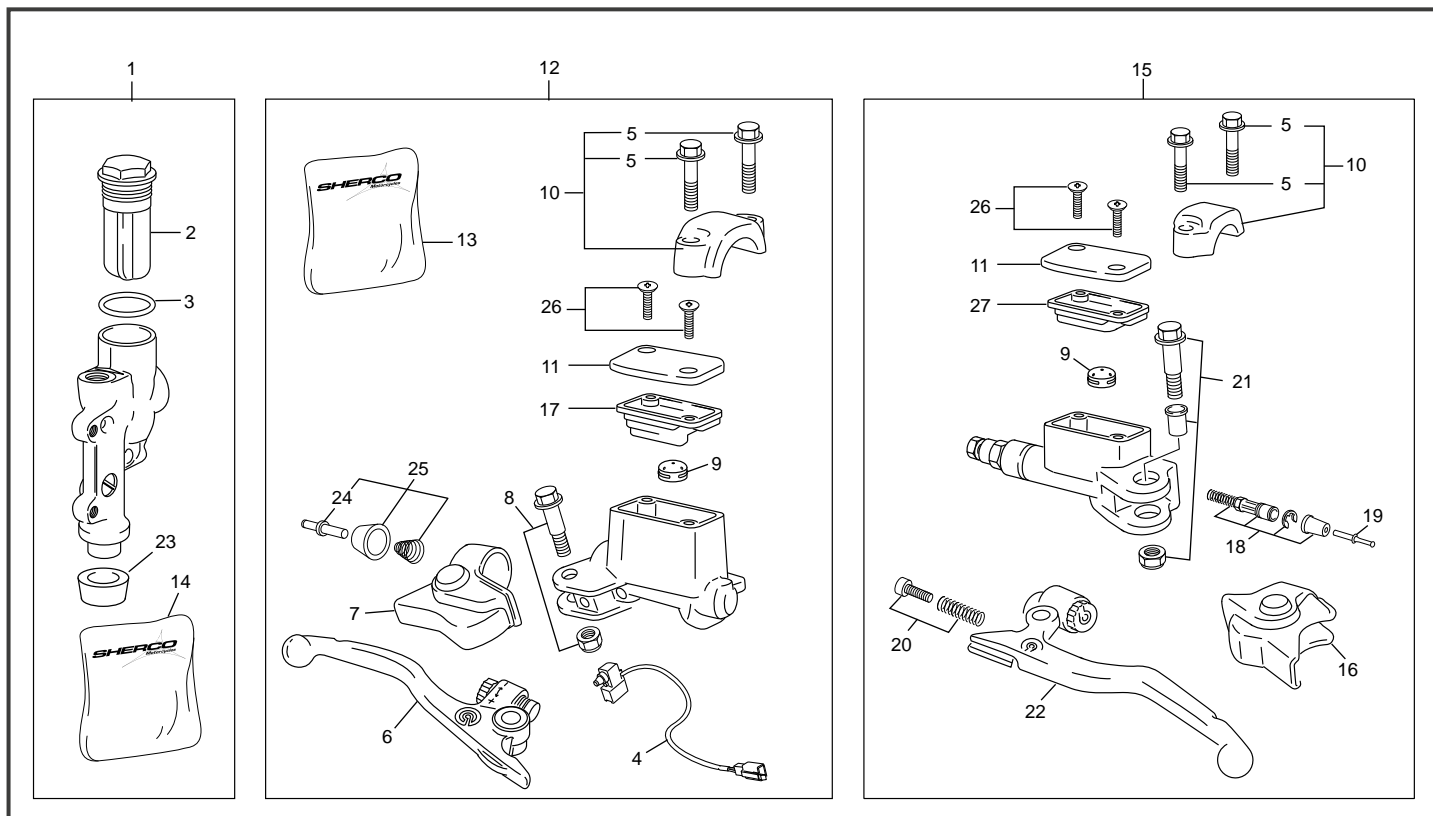

POS.	125 SE-R	FRANÇAIS	ENGLISH	ESPAÑOL
1	3560	MAITRE CYLINDRE ARRIÈRE	REAR MASTER CYLINDER	BOMBA FRENO TRASERO
2	3696	BOU. DE REMPLISSAGE MAITRE CYLI. AR.	REAR BRAKE CYLINDER COVER	TAPÓN DE LA BOMBA FRENO TRASERO
3	3695	JOINT BOUCHON REMP. MAIT. CYLI. AR.	FOOT BRAKE CYLINDER GASKET	JUNTA DEL TAPÓN DEL BOMBA FRE.TRAS.
4	5705	CONTACT FEUX STOP DE FREIN AVANT	CONTACT FRONT BRAKE LIGHT	INTERRUPTOR FRENO
5	5712	VIS BRIDE FIXATION MAITRE CYL. BREMBO	CLAMP SCREW BREMBO	TOR. TAPA FIJ. BOMBA EMBRAGE BREMBO
6	5707	LEVIER DE FREIN AVANT	HAND BRAKE LEVER	MANETA FRENO
7	5708	CAOUTCHOUC DE PROT. LEVIER FREIN	PROTECTIONS CAP HAND BRAKE CYLI.	PROTECCIÓN DEL MANETA
8	5709	ASSEMBLE PIVOT DE LEVIER FREIN AVANT	LEVER SCREW ASSEMBLY	TOR. Y TUERCA MANETA FRENO DELA.
9	4061	VALVE ANTIBULLE	VALVE ANTI BUBBLE	VÁLVULA ANTI BURBUJA
10	5711	VIS + DEMI LUNE MAITRE CYL. FREIN AVA.	CLAMP ASSEMBLY NATURE + SCREW	TAPA FIJA. BOMBA FRENO DEL. + TORN.
11	5721	COUVERCLE MAITRE CYLI. AVA.	HANDBRAKE CYLI. COVER NATURE	TAPA BOMBA FRENO DELANTERO
12	5544	MAITRE CYLINDRE FREIN AVANT COMP.	HANDBRAKE CYLINDER ASSEMBLY	BOMBA FRENO DELANTERO
13	5713	KIT RÉPARATION MAITRE CYL. FREIN AV.	REP KIT FRONT CALIPER	KIT DE REPARACIÓN PINZA DELANTERO
14	4059	KIT RÉPARATION MAITRE CYL. FREIN AR.	REP KIT REAR CALIPER	KIT DE REPARACIÓN PINZA TRASERO
15	6868	POMPE EMB CPL. BREMBO 9 MM	CLUTCH MASTER CYLINDER ASSY 9 MM	GRUPO BOMBA EMBRAGUE 9MM
16	4060	PROTECTION LEVIER EMBRAYAGE	PROTECTION CAP HAND CLUTCH	TAPA MANETA EMBRAGE
17	8387	MEMBRANE FREIN	BRAKE RUBBER	GOMA DE LA TAPA FRENO
18	7218	KIT RÉPARATION PISTON	REP KIT	KIT DE REPARACIÓN
19	5716	TIGE POUSSÉ EMBR. BREMBO AVEC CACHE	PUSH ROD CLUTCH BREMBO	VARILLA EMBRAGE BREMBO
20	4065	GUIDE RESSORT	BOLT	MUELLE + TORNILLO
21	5718	ASSEMBLE PIVOT DE LEVIER EMB.	SCREW-NUT MASTER CYLINDER CLUTCH	TOR. Y TUERCA MANETA EMBRAGUE
22	5719	LEVIER COMP. EMBRAYAGE	CLUTCH LEVER	MANETA COMPLETA
23	4404	CACHE POUSSIÈRE	DUST COVER	TAPÓN PROTECCIÓN
24	5717	TIGE DE FREIN AVANT	FRONT BRAKE PUSH ROD	VARILLA FRENO DELANTERO
25	5929	KIT TIGE DE FREIN AVANT	FRONT BRAKE PUSH ROD KIT	KIT VARILLA DE FRENO DELANTERO
26	5720	VIS COUVERCLE	COVER SCREW	TORNILLO TAPA
27	5706	MEMBRANE EMBRAYAGE	CLUTCH RUBBER	GOMA DE LA TAPA

Radiateur Radiator / Radiador

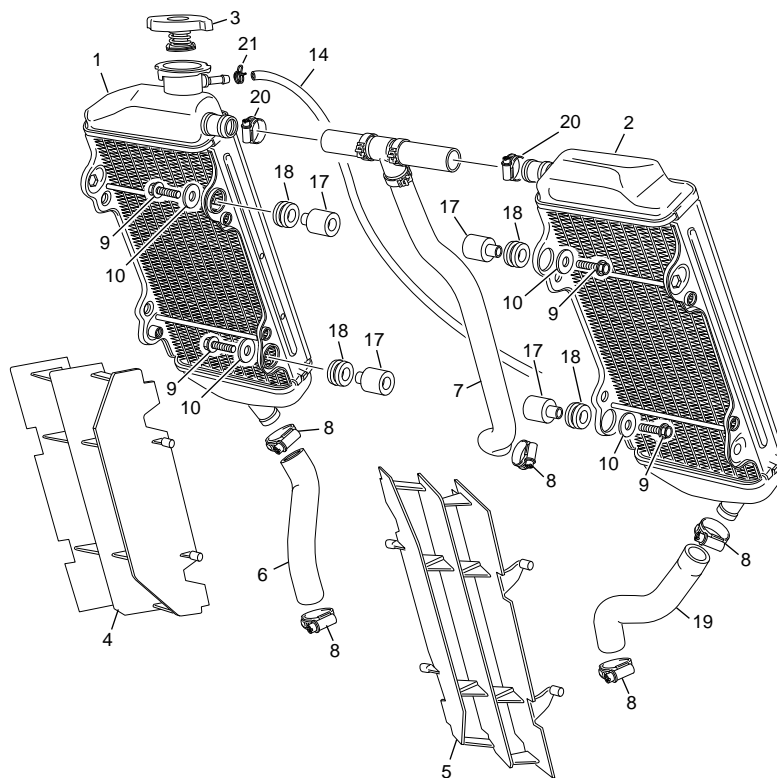

POS.	125 SE-R	FRANÇAIS	ENGLISH	ESPAÑOL
1	6914	RADIATEUR DROITE SE 125	RIGHT RADIATOR SE 125	RADIATOR DER END 125 SE
2	6915	RADIATEUR GAUCHE 125 SE	LEFT RADIATOR 125 SE	RADIATOR IZQ END 125 SE
3	7524	BOUCHON RADIATEUR CRENELE 1.8 BAR	RADIATOR CAP 1.8 BAR	TAPON RADIADOR 1.8 BAR
4	4521	GRILLE RADIATEUR DROITE END 250/300 2T	RIGHT RADIATOR GUARD	GRILLA RADIATOR DER END 250/300 2T
5	4522	GRILLE RADIATEUR GAUCHE END 250/300 2T	LEFT RADIATOR GUARD	GRILLA RADIATOR IZQ END 250/300 2T
6	6870	DURITE INF DROITE 125 SE	RIGHT INFERIOR RADIATOR HOSE	MANGUITO INF DER 125 SE
7	4471	DURITE SUPERIEUR 250 END 2T	SUPERIOR RADIATOR HOSE	MANGUITO SUP 250 END 2T
8	H262	COLLIER CLIC 86/245 25/27	HOSE CLAMP 86/245 25/27	ABRAZADERA 86/245 25/27
9	0547	VIS TH EP 6 X 30	TH EP SCREW 6 X 30	TORNILLO TH EP 6 X 30
10	4939	RONDELLE M6 X 22 INOX	WASHER M6 X 22 INOX	ARANDELA M6 X 25 INOX
14	3910	DURITE EXP RADIATEUR L900 250 300 END 2012	RADIATOR RUBBER HOSE L= 800	TUBO EXP. RADIDOR L900 250 300 END 2012
17	4265	ENTRETOISE RADIATEUR 250 2T END	RADIATOR SPACER 250 2T END	CASQUILLO RADIADOR 250 2T END
18	H059	SILENTBLOCK RADIATEUR	RADIATOR SILENTBLOC	SILENTBLOCK RADIADOR
19	6869	DURITE INF GAUCHE 125 SE	LEFT INFERIOR RADITOR HOSE	MANGUITO INF IZQ 125 SE
20	H261	COLLIER CLIC 86/230 23.5/25.5	HOSE CLAMP 86/230 23.5/25.5	ABRAZADERA 86/230 23.5/25.5
21	5934	COLLIER SERRAGE DOUBLE FIL 10.4 - 11.0	COLLAR 10.4 - 11.0	SEEGER TUBOS 10.4 - 11.0

Faisceau électrique Electrical system / Instalación eléctrica

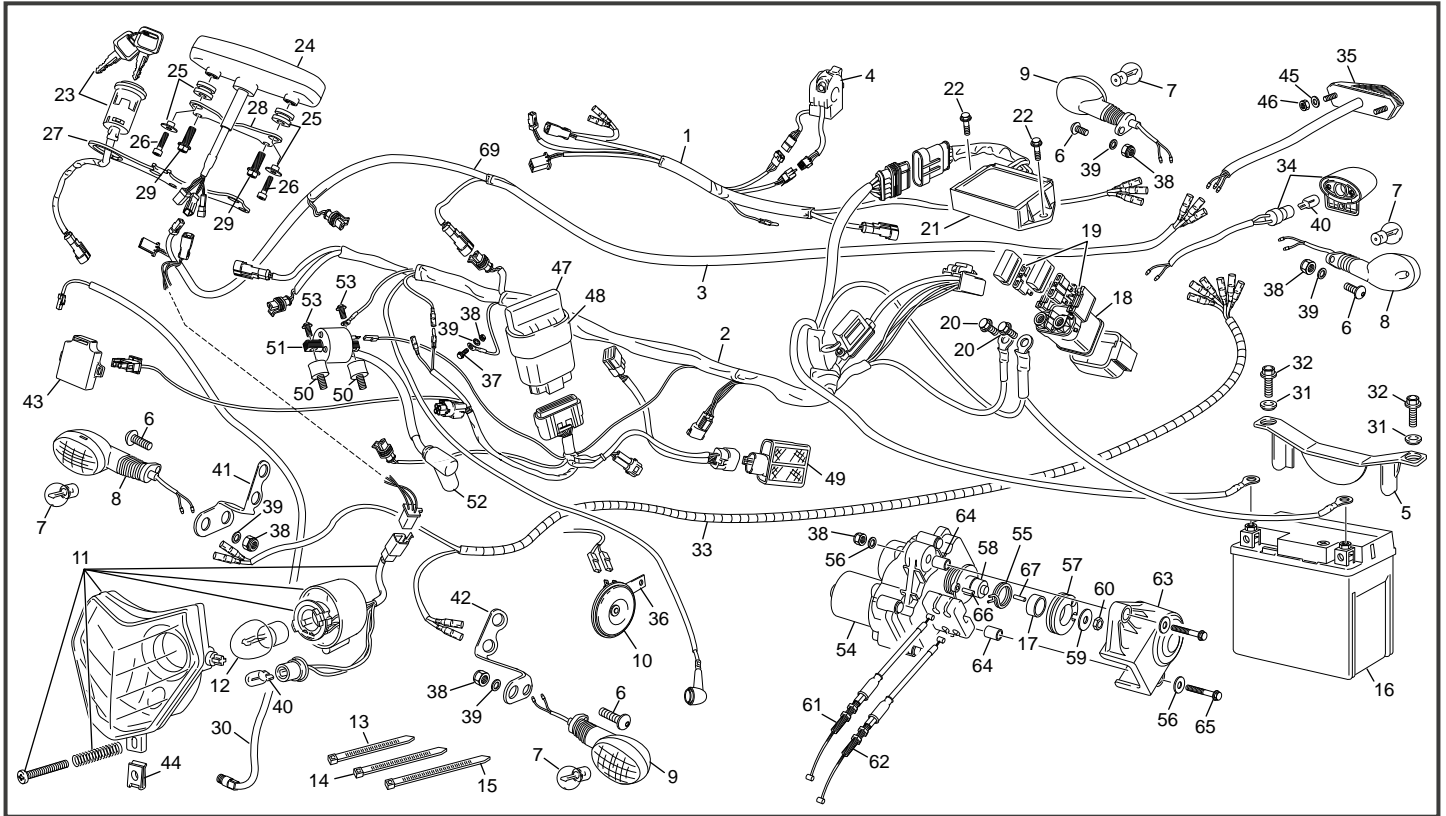

POS.	125 SE-R	FRANÇAIS	ENGLISH	ESPAÑOL
1	6784	FAISCEAU ELECT LUMIERE END EURO 4	ELECTRIC CABLE GENERAL END EURO 4	INSTALACION ELECTRICA PRINCIPAL END EURO 4
2	6827	FAISCEAU ELECT GENERAL ET CDI SE 125	ELECTRIC CABLE GENERAL & CDI SE 125	INSTALACION ELECTRICA GENERAL CDI SE 125
3	6845	FAISCEAU ELECT RACING END 250/300 EURO4	RACING ELEC. CABLE SYSTEM END EURO4	INSTALATION ELECTRIC RACING END EURO4
4	0413	COMMODO GAUCHE END 450	LEFT SWITCH ASSEMBLY	COMODO ELECTRIC END 450
5	3099	CALE BATERIE END 2012	BATTERY MOUNTING BRACKET	SUPPORTO BATERIE END 2012
6	M283	VIS BHC 6 X 16 1093 ZI BL	SCREW BHC M6X16	TORNILLO 6 X 16 ULS CIN BLA
7	C405	AMPOULE CLIGNO 10W 12V	LIGHT BULB 10W 12V	BOMBILLA INTERMITENTES 10W 12V
8	5004	CLIGNOTEUR AVD/ARG 50 END	TURN LIGHT/FRONT RIGHT - REAR LEFT	INTERMITENTE DEL.DER./TRAS.IZQ 50 END
9	5005	CLIGNOTEUR AVG/ARD 50 END	TURN LIGHT/FRONT LEFT - REAR RIGHT	INTERMITENTE DEL./IZQU TRAS./DER 50 END.
10	0447	CLAXON END 450	HORN	CLAXON END 450
11	3053	OPTIQUE PHARE END/SM EVO	HEADLIGHT ASSEMBLY	FARO DEL END/SM EVO
12	C403	AMPOULE PHARE HOMOL 35/35W 12V	HEADLIGHT BULB 35/35W 12V	BOMBILLA FARO 35/35 12V
13	M330	COLLIER RISLAN 178 X 4.8	ZIP TIE 178X4.8	ABRAZADERA 178 X 4.8
14	C441	COLLIER RYSLAN 280 X 4.8	ZIP TIE 208X4.8	ABRAZADERA 280 X 4.8
15	1367	COLLIER NYLON 135 X 2.5 NOIR	COLLIER 135 X 2.5	ABRAZADERA 135X 2.5
16	3094	BATTERIE YUASA 12 V 5 AMP END 2012	BATTERY 12V 5A	BATERIE YUASA 12V 5 AMP END 2012
17	6907	BAGUE VALVE IGUS 125 SE	PULLEY FRICTION SLEEVE	MUELLES VALVULA 2 250 2T END
18	0367	RELE DEMARREUR END 450	STARTER RELAY	STARTER RELEY END 450
19	0661	FUSIBLE 30 A LITLIFUSE	FUSE 30A	FUSIBLE 30 A LITLIFUSE
20	0592	VIS TH EP 6 X 8	SCREW THEP 6 X 8	TORNILLO TH EP 6 X 8
21	7215	REGULATEUR END 250/510 EVO	REGULATOR	REGULADOR END 250/510 EVO
22	0546	VIS TH EP 6 X 20	SCREW THEP M6X20	TORNILLO TH EP 6 X 20
23	3774	BLOC CLE DEMARRAGE 2T END 250/300 END 2012	IGNITION SWITCH	BLOC LLAVE ARRANQUE END 250/300 END 2012
24	4387	COMPTEUR DE VITESSE END TRAIL TECH 2013	SPEEDOMETER TRAIL TECH	VELOCIMETRO END TRAIL TECH 2013
25	4513	KIT SILENBLOC ENTRETOISE COMPTEUR END	DASHBORD SILENBLOC + SPACER (V1)	KIT SILENBLOC VELOCIMETRO END TRAIL TECH
26	M267	VIS CHC 4 X 16	SCREW VIS CHC 4 X 16	TORNILLO 4 X 16 ALLEN
27	4389	SUPPORT COMPTEUR TRAIL TECH EURO 4	SPEEDOMETER MOU. BRACKET	SUPPORTE VELOCIMETRO TRAIL TECH EURO 4
28	4526	SUPPORT COMPTEUR TRAIL TECH RACING	SPEEDOMETER MOU. BRACKET RACING	SUPPORTE VELOCIMETRO TRAIL TECH RACING
29	0943	VIS TH EP 6 X 12	SCREW THEP M6X12	TORNILLO TH EP M6 X 12
30	4508	CABLE CAPTEUR COMPTEUR END TRAIL TECH	SPEECLOMETER SENSOR	INSTALACION SENSOR VELOCIMTRRO END
31	3096	ENTRETOISE CARROSSERIE 2.3 END 2012	SPACER	CASQUILLO 2.3 INOX CARROCERIA END 2011
32	0553	VIS TH EP 5 X 12	SCREW THEP M5X12	TORNILLO TH EP 5 X 12
33	3509	FAISCEAU ELECT ACCESSOIRE 250 300 END 12	ELECTRI. SYSTEM ACCESSORY	INSTALATION ELECTRIC ACCESSOIRE END
34	3510	FEU ECLAIRAGE PLAQUE END 2012	PLATE NUMBER REAR LIGHT	FARO TRAS HOMOLO END 2012
35	3506	FEU AR END 450 2012	REAR LIGHT AND STOP	RACING FARO TRAS END 450 2012

*Sherco se réserve les droits de modification des références, merci de contrôler sur le portail Sherconetwork avant toute commande. - *Sherco reserves the right to make change on the references, please check on your Sherconetwork portal before ordering.
*Sherco se reserva el derecho para hacer modificaciones sobre las referencias. Por favor, verifica en el Sherconetwork antes de hacer un pedido.

Faisceau électrique Electrical system / Instalación eléctrica

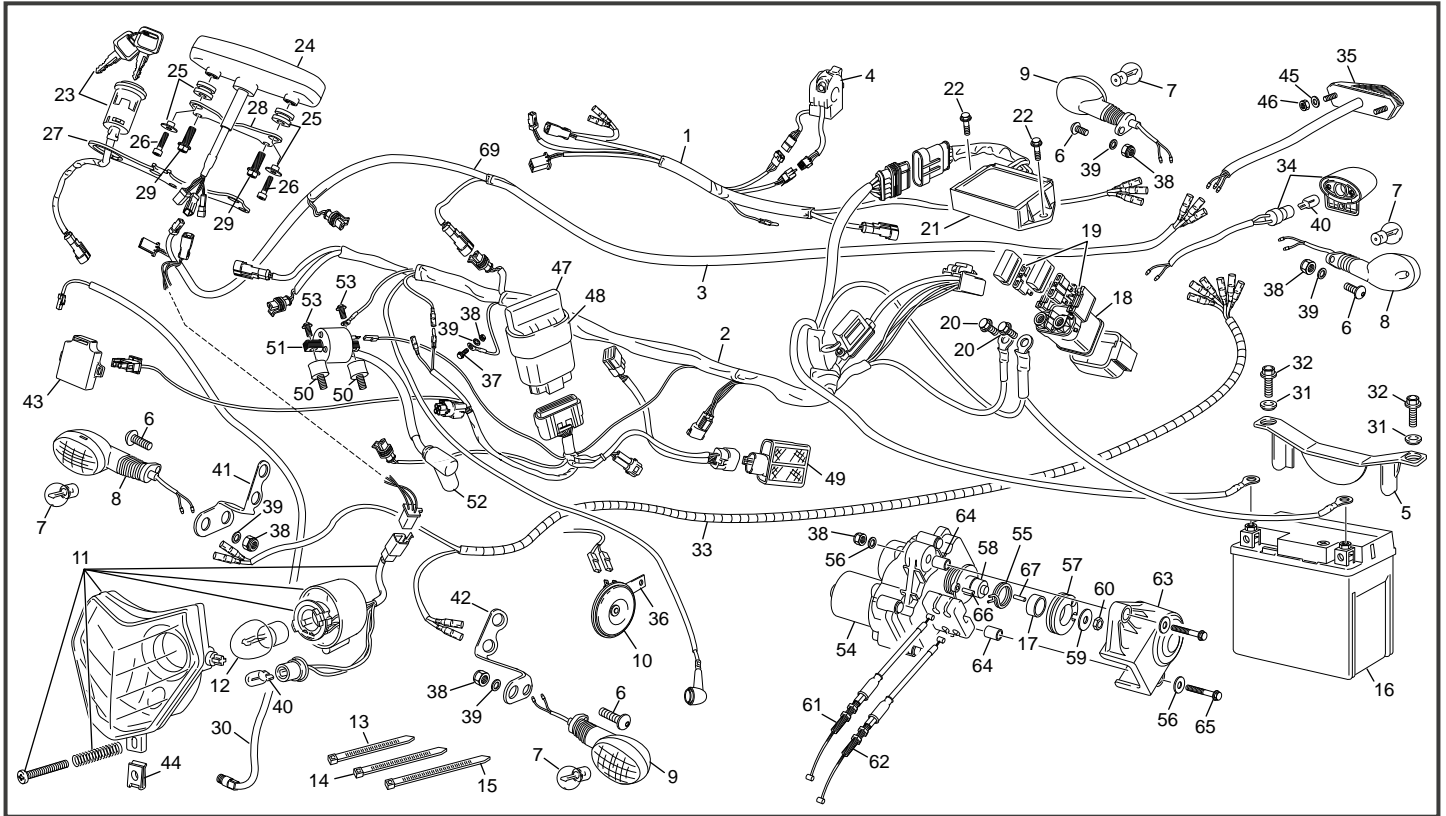

POS.	125 SE-R	FRANÇAIS	ENGLISH	ESPAÑOL
36	4088	SUPPORT AVERTISSEUR 250/300 END 2012	HORN FISSION	SOPORTE KLAKSON 250/300 END 2012
37	M283	VIS BHC 6 X 16 1093 ZI BL	SCREW BHC 6 X 16	TORNILLO 6 X 16 ULS CIN BLA
38	M306	ECROU NYLSTOP M6 0368.6	NUT NYLSTOP M6	TUERCA NYLSTOP M6
39	M317	RONDELLE 6 X12 0407 6	WASHER M6	ARANDELA 6 DIN 125 A
40	C067	AMPOULE POSITION W5W	POSTION BULB W5W	BOMBILLA POSICIÓN W5W
41	8399*	SUPPORT CLIGNOTANT DROIT	SUPPORT RIGHT TURN LIGHT	SOPORTE INTERMITENTES DER.
42	8400*	SUPPORT CLIGNOTANT GAUCHE	SUPPORT LEFT TURN LIGHT	SOPORTE INTERMITENTES IZQ.
43	0364	CENTRALE CLIGNOT END 450	INDICATIVE LIGHT SYSTEM	CENTRAL INTERMIENCIA END 450
44	M378	ECROU CLIP M5	NUT CLIP M5	TUERCA CLIP M5
45	M318	RONDELLE 4X12 0411	WASHER M4	ARANDELA 4X12
46	M307	ECROU NYLSTOP M4 0368.4	NUT M4	TUERCA NYLSTOP M4
47	7198	CDI KOCUSAN 125 2T 2017	CDI	CDI KOCUSAN 125 2T 2017
48	3586	CAUTCHOUX SUPPORT CDI HI TRIAL	CDI RUBBER	GOMA CDI HI TRIAL
49	4073	ACTUATEUR MOTEUR CONTROL 250/300 2T END	ACTUATOR MOTOR CONTROLER	CONTRILADOR MOTOR ACTUATOR 2T END
50	4729	SILENBLOC BOBINE 250 2T END	COIL SILENBLOC	SILENBLOC BOBINA 250 2T END
51	4003	BOBINE END 250 2T	IGNITION COIL	BOBINA END 250 2T
52	7393	ANTIPARASITE NGK CPL SE	SPARK PLUG CAP NGK	CTO PIPA BUJIA SE
53	0656	VIS TH EP 6 X 16	SCREW THEP M6X16	TORNILLO TH EP 6 X 16
54	8304	ACTUATEUR MOTEUR 125 2T END	ACTUATOR MOTOR	MOTOR ACTUATOR 125 2T END
55	6906	RESSORT DE VALVE 125 SE	ACTUATOR SPRING	MUELLES VALVULA 2 250 2T END
56	M317	RONDELLE 6 X12 0407 6	WASHER M6	ARANDELA 6 DIN 125 A
57	5899	POULIE ACTUATEUR 125 SE	ACTUATOR PULLEY 125	POLEA MANDA VÁLVULA 125 SE
58	6903	CLOCHE DE POULIE COMMANDE VALVE 125 SE	ACTUATOR PULLEY BASKET	CAMPANA POLEA MANDA VÁLVULA 125 SE
59	M379	RONDELLE M5 X 15	WASHER M5	ARANDELA M5X15
60	M355	ECROU NYLSTOP M5	NUT NYLSTOP M5	TUERCA NYLSTOP M5
61	5906	CABLE ACTUATEUR SUPERIEUR 125 SE	ACTUATOR CABLE SUPERIOR 125 SE	CABLE ACTUATOR SUPERIOR 125 SE
62	5907	CABLE ACTUATEUR INFERIEUR 125 SE	ACTUATOR CABLE INFERIOR 125 SE	CABLE ACTUATOR INFERIOR 125 SE
63	4740	COUVERCLE POULIE ACUATEUR 250 2T END	ACTUATOR MOTOR COVER	TAPA ACUATOR POLEA 250 2T END
64	0008	DOUILLES CENTRAGE 8X6X11	DOWEL	CENTRADOR 8X6X11
65	0591	VIS TH EP 6 X 40	SCREW THEP M6 X 40	TORNILLO TH EP 6 X 40
66	6904	AIGUILLE 2.5X7.8 G2	NEEDLE 2.5X7.8 G2	AGUJA 2.5X7.8 G2
67	6905	AIGUILLE 2.5X9.8 G2	NEEDLE 2.5X9.8 G2	AGUJA 2.5X7.8 G2

* —| NOUVELLE PIECE / NEW PART / PIEZA NUEVA

Roue avant Front wheel / Rueda delantera

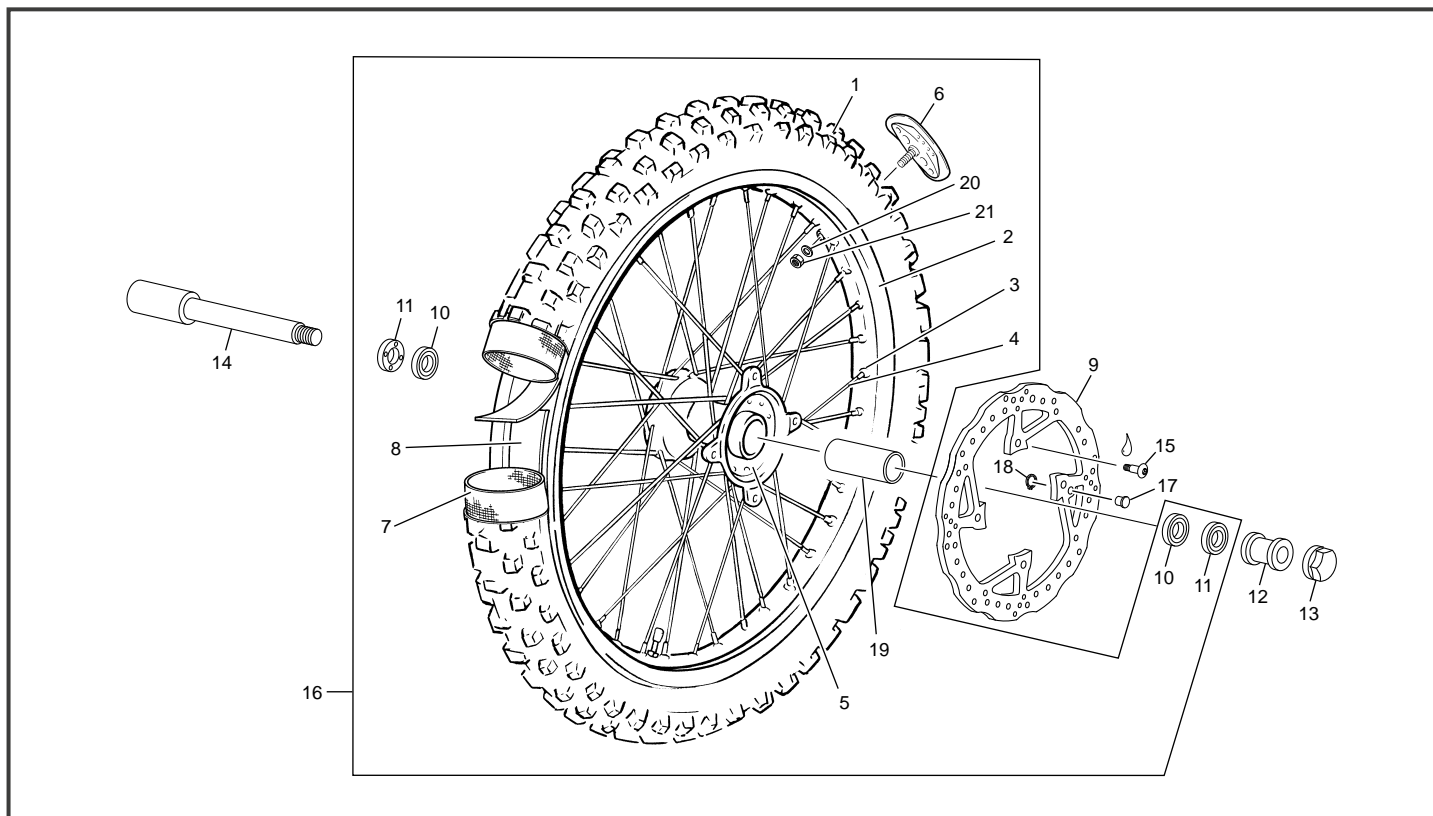

POS.	125 SE-R	FRANÇAIS	ENGLISH	ESPAÑOL
1	7392	PNEU AVANT 90/90-21 54R F TT	FRONT TIRE 90/90-21 54R F TT	PNEUMÁTICO DEL. 90/90-21 54R F TT
2	1203	JANTE AV 1,6 X 21 NOIR	FRONT RIM 1,6 X 21 BLACK	LLANTA DEL 1,6 X 21 NEGRO
3	6181	ECROU RAYON	SPOKE NIPPLE	TUERCA RADIO
4	6183	RAYON AVANT 3,5/3/3,5 X 233 (36)	SPOKE 3,5/3/3,5 X 233 (36)	RADIO DELANTERO 3,5/3/3,5 X 233 (36)
5	0822	MOYEU COMPLET AV	HUB	BUJE CPL
6	3575	GRIPSTER	RIM LOCK	AGARRA CUBIERTAS
7	0313	CHAMBRE A AIR 21	INNER TUBE 21	CAMARA 21
8	0314	FOND JANTE AV 21	RIM BAND 21	FONDO LLANTAS 21
9	6751	DISQUE FREIN AVANT	FRONT BRAKE DISC	DISCO FRENO DELANTERO
10	0175	ROULEMENT DE MOYEU 6004 2RS	HUB BEARING 6004 2RS	RODAMIENTO BUJE 6004 2RS
11	0706	JOINT A LEVRES 25X42X7	OIL SEAL 25X42X7	RETÉN 25X42X7
12	6750	ENTRETOISE ROUE AVANT XPLOR	FRONT WHEEL SPACER XPLOR	CASQUILLO RUEDA DEL XPLOR
13	0316	ECROU ROUE AVANT	FRONT AXLE NUT	TUERCA RUEDA DELANTERA
14	6759	AXE DE ROUE AVANT	FRONT WHEEL AXLE	EJE RUEDA DELANTERA
15	0452	VIS SPECIALE DISQUE	ROTOR BOLTS	TORNILLO ESPECIAL DISCO FRENO
16	7608	ROUE AVANT SANS DISQUE NOIRE	FRONT WHEEL WITHOUT DISC BLACK	RUEDA DELANTERA SIN DISCO NEGRA
17	4529	AIMANT	MAGNET	IMÁN
18	7608	CIRCLIP Ø9	CIRCLIP Ø9	CIRCLIP Ø9
19	4972	ENTRETOISE ROUE AVANT	FRONT HUB SPACER	CASQUILLO RUEDA
20	5497	RONDELLE	WASHER RIM LOCK	ARRANDELA
21	3481	ECROU	NUT RIM LOCK	TUERCA

Roue arrière Rear wheel / Rueda trasera

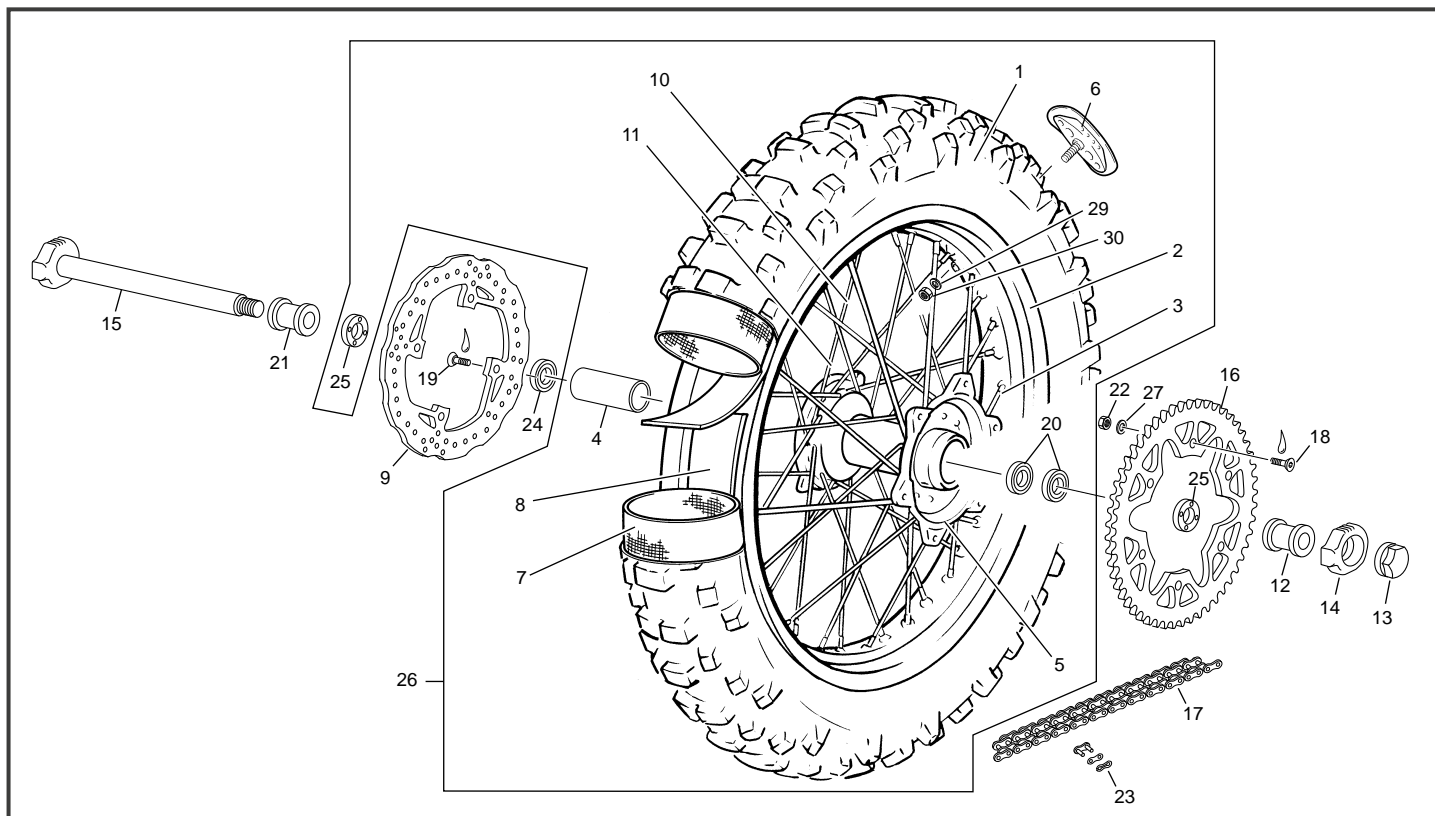

POS.	125 SE-R	FRANÇAIS	ENGLISH	ESPAÑOL
1	7391	PNEU ARRIÈRE 140X18 70R R TT	REAR TIRE 140X18 70R R TT	NEUMÁTICO TRASERO 140X18 70R R TT
2	1204	JANTE ARRIÈRE 2.15X18 NOIRE	REAR RIM 2.15 X 18 BLACK	LLANTA TRAS 2.15 X 18 NEGRA
3	6182	ECROU RAYON	SPOKE NIPPLE	TUERCA RADIO
4	4973	ENTRETOISE ROUE ARRIÈRE	REAR WHEEL SPACER	CASQUILLO RUEDA TRASERA
5	0823	MOYEU COMPLET ARRIÈRE	REAR HUB	BIJUE TRASERO
6	3576	GRIPSTER 2.15" ARRIÈRE	REAR RIM LOCK	AGARRA CUBIERTAS TRASERO
7	0324	CHAMBRE AIR 18"	REAR INNER TUBE 18	CAMARA 18
8	0325	FOND DE JANTE 18"	REAR RIM BAND 18	FONDO LLANTA 18
9	3499	DISQUE FREIN ARRIÈRE	REAR BREAK DISC	DISCO FRENO TRASERO
10	0711	RAYON POST. 193MM (18)	SPOKE 193MM (18)	RADIO TRAS. 193MM (18)
11	0712	RAYON POST. 197MM (18)	SPOKE 197MM (18)	RADIO TRAS. 197MM (18)
12	0343	ENTRETOISE ROUE ARRIÈRE GAUCHE	LH REAR WHEEL SPACER	CASQUILLO RUEDA TRAS. IZQ.
13	0329	ECROU ROUE ARRIÈRE	REAR AXLE NUT	TUERCA RUEDA TRASERO
14	0327	TENSEUR CHAÎNE DROIT	RH CHAIN TENSIONER	SENSOR CADENA DER.
15	0326	AXE DE ROUE ARRIÈRE	REAR AXLE	EJE RUEDA TRAS.
16	6864	COURONNE ARRIÈRE 51 D	REAR SPROCKET 51 T	CORONA 51D
17	5065	CHAÎNE 114M	CHAIN 114M	CADENA 114M
18	0454	VIS SPECIALE COURONNE	SPROCKET BOLTS	TORNILLO ESPECIAL CORONA
19	0452	VIS SPECIALE DISQUE	BRAKE ROTOR BOLTS	TORNILLO ESPECIAL DISCO FRENO
20	0716	ROULEMENT 6005 2RS1 25X47X12	BEARING 6005 2RS1 25X47X12	RODAMIENTO 6005 2RS1 25X47X12
21	3495	ENTRETOISE ROUE ARRIÈRE DROITE	RH REAR WHEEL SPACER	CASQUILLO RUEDA TRAS. DER.
22	M305	ECROU NYLSTOP M8 0368.10	NUTNYLSTOP M8	TUERCA NYLSTOP M8
23	R473	ATTACHE RAPIDE	CONNECTING LINK	ENGANCHE
24	0707	ROULEMENT 63005 2RS 25X47X16	BEARING 63005 2RS 25X47X16	RODAMIENTO 63005 2RS 25X47X16
25	0718	JOINT A LÈVRE 32X42X7	OIL SEAL 32X42X7	RETÉN 32X42X7
26	6180	ROUE ARR. SANS DIS./COURON. NOIRE	REAR WHEEL WITH. DISK/SPOKET BLA.	RUEDA TRAS. SIN DISCO/CORONA NEG
27	C430	RONDELLE M8	WASHER M8	ARANDELA M8
29	5497	RONDELLE	WASHER RIM LOCK	ARRANDELA
30	3481	ECROU	NUT RIM LOCK	TUERCA

Guidon Handlebar / Manillar

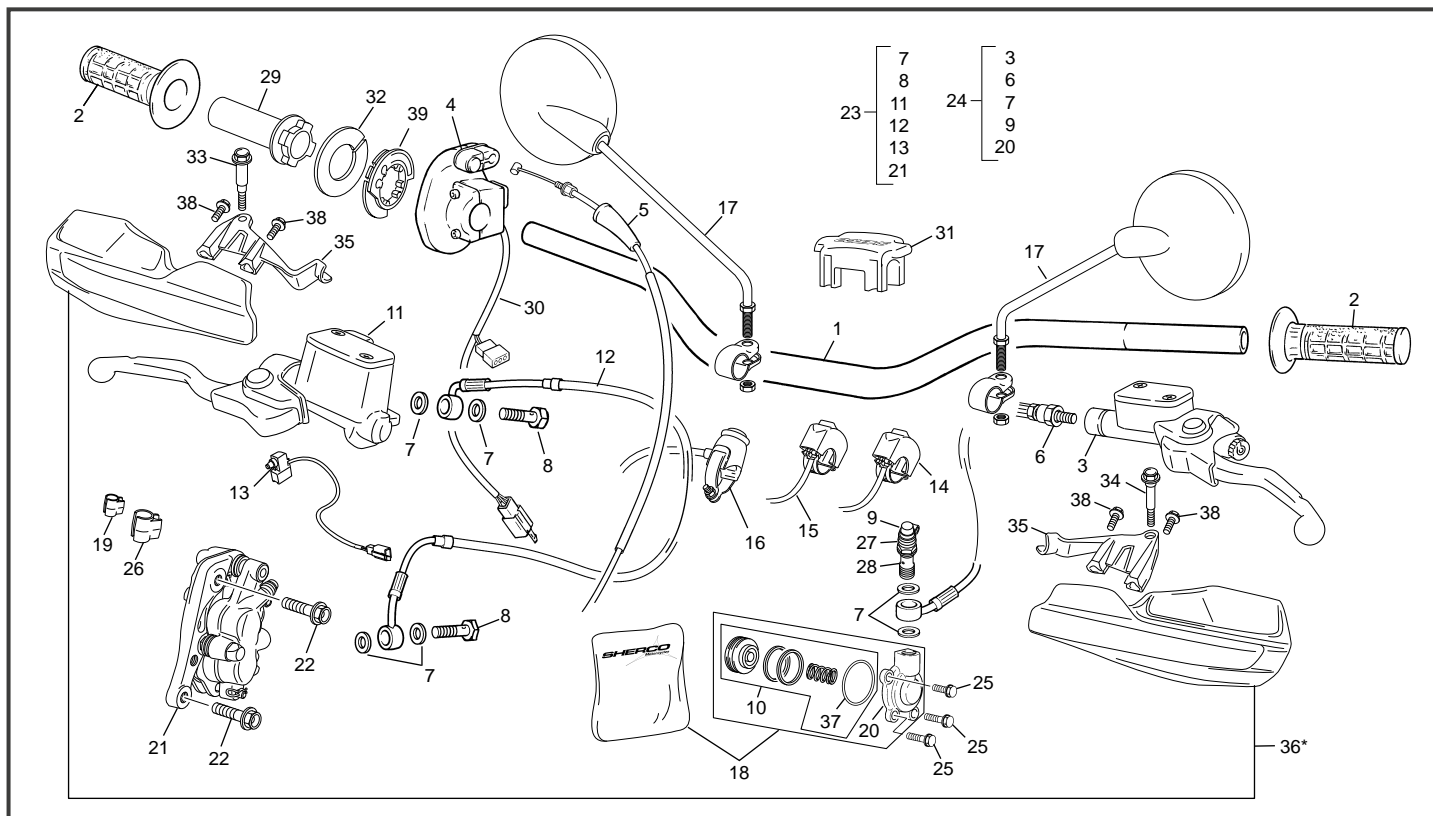

POS.	125 SE-R	FRANÇAIS	ENGLISH	ESPAÑOL
1	6978	GUIDON NOIR V2	HANDLEBAR BLACK V2	MANILLAR NEGRO V2
2	6100	GROUPE POIGNEES PAIRE	GRIP SET - SHERCO	JUEGO EMPUÑADURAS SHERCO
3	6868	POMPE EMB CPL	CLUTCH MASTER CYLINDER ASSEMBLY	CTO. BOMBA EMBRAGUE
4	4386	COMMANDE DE GAZ	THROTTLE GAS	MANDO GAS
5	4425	CABLE DE GAZ	THROTTLE CABLE	CABLE DE GAS
6	3617	DURITE EMBRAYAGE	CLUTCH HOSE ASSEMBLY	LATIGUILLO EMBRAGUE
7	3620	RONDILLE BANJO	ALUMINIUM SEAL	ARANDELA BANJO
8	3619	VIS BANJO M. CYL. FREIN AV	BANJO BOLT	TORNILLO RACORD M10X21
9	3618	CAPUCHON	CAP	CONJ. RACORD CON SANGRADO
10	8381	CYLINDRE RECEPTEUR D'EMBRAYAGE END	CYLINDRE CLUTCH RECEIVER END	CILINDRO BOMBIN EMBRAGE END
11	5544	POMPE FREIN AV CPL	FRONT BRAKE MASTER CYLINDER ASSY	BOMBA FRENO DELANTERO
12	3563	DURITE FREIN AV TEFLON	FRONT BRAKE HOSE 450 TEFLON	LATIGUILLO FRENO DELANTERO TEFLÓN
13	3697	CONTACT FREIN AVANT	CONTACT FRONT BRAKE LIGHT	INTERRUPTOR FRENO DELANTERO
14	3508	COMMUTATEUR MOTEUR RACING END	COMMAND ENGINE RACING END	CONMUTADOR MOTOR RACING END
15	3507	COMMUTATEUR PHARE RACING	COMMAND LIGHT RACING	CONMUTADOR FARO RACING
16	3658	BOUTON STOP MOTEUR	STOP ENGINE	STOP MOTOR
17	S232	RETROVISEUR	MIRROR	RETROVISOR
18	8131	KIT REPARATION PISTON EMB.	CLUTCH MASTER CYLINDER REPAIR KIT	KIT REPARACIÓN BOMBA EMBRAGUE
19	6635	CLIP FIXATION CABLE COMPTEUR PETIT	WIRE FIXING CLIP SMALL	CLIP FIJACION CABLE CUENTAQUILOM. PEQUENO
20	3915	RECEPTEUR EMB CPL	CLUTCH SLAVE CYLINDER	RECEPTOR EMBRAGUE CPL
21	3561	ETRIER FREIN AVANT	FRONT CALIPER ASSY	PINZA FRENO DELANTERO
22	4620	VIS D'ÉTRIER THEP M8X32	FRONT CALIPER SCREW THEP M8X32	TORNILLO DE LA PINZA THEP M8X32
23	5540	GROUPE FREIN AVANT COMPLET	COMP. FRONT BRAKE HYDR. SYSTEM	CTO. FRENO DELANTERO
24	8309	GROUPE EMBRAYAGE COMPLET	COMPLETE CLUTCH HYDRAULIC SYSTEM	CTO. EMBRAGUE
25	0943	VIS THEP M6X12	SCREW THEP M6X12	TORNILLO THEP M6X12
26	6636	CLIP FIXATION CABLE COMPTEUR GRAND	WIRE FIXING CLIP BIG	CLIP FIJACION CABLE CUENTAQUILOM. GRANDE
27	3639	PURGEUR	BLEEDER SCREW	TORNILLO DE PURGA
28	3640	RACCORD BANJO	BANJO BOLT	TORNILLO BANJO
29	4974	TUBE COMMANDE DE GAZ	PIPE THROTTLE CONTROL	TUBO MANDO DE GAS
30	4975	CONNECTEUR DOUBLE COURBE	SWITCH MAPPING	CONECTOR DOBLE MAPATURA
31	1270	MOUSSE GUIDON	FOAM HANDLEBAR	ESPUMA MANILLAR
32	1970	RONDILLE FRICTION POIGNEE GAZ	PLATE THRUST	PLACA DE EMPUJE
33	6214	VIS PARES MAINS SEF GAUCHE	HAND GUARD SCREW CLUTCH SIDE	TORNILLO PARA MANO SEF IZQUIERDA
34	6213	VIS PARES MAINS DROIT	HAND GUARD SCREW BRAKE SIDE	TORNILLO PARA MANO SEF DERECHA
35	6261	SUPPORT PARES MAINS SHERCO JEU SE SEF	HAND GUARD BRACKETS BLACK SHERCO SET END	SOPORTE PARA MANO JUEGO SHERCO END

*Sherco se réserve les droits de modification des références, merci de contrôler sur le portail Sherconetwork avant toute commande. - *Sherco reserves the right to make change on the references, please check on your Sherconetwork portal before ordering.
 *Sherco se reserva el derecho para hacer modificaciones sobre las referencias. Por favor, verifica en el Sherconetwork antes de hacer un pedido.

Guidon Handlebar / Manillar

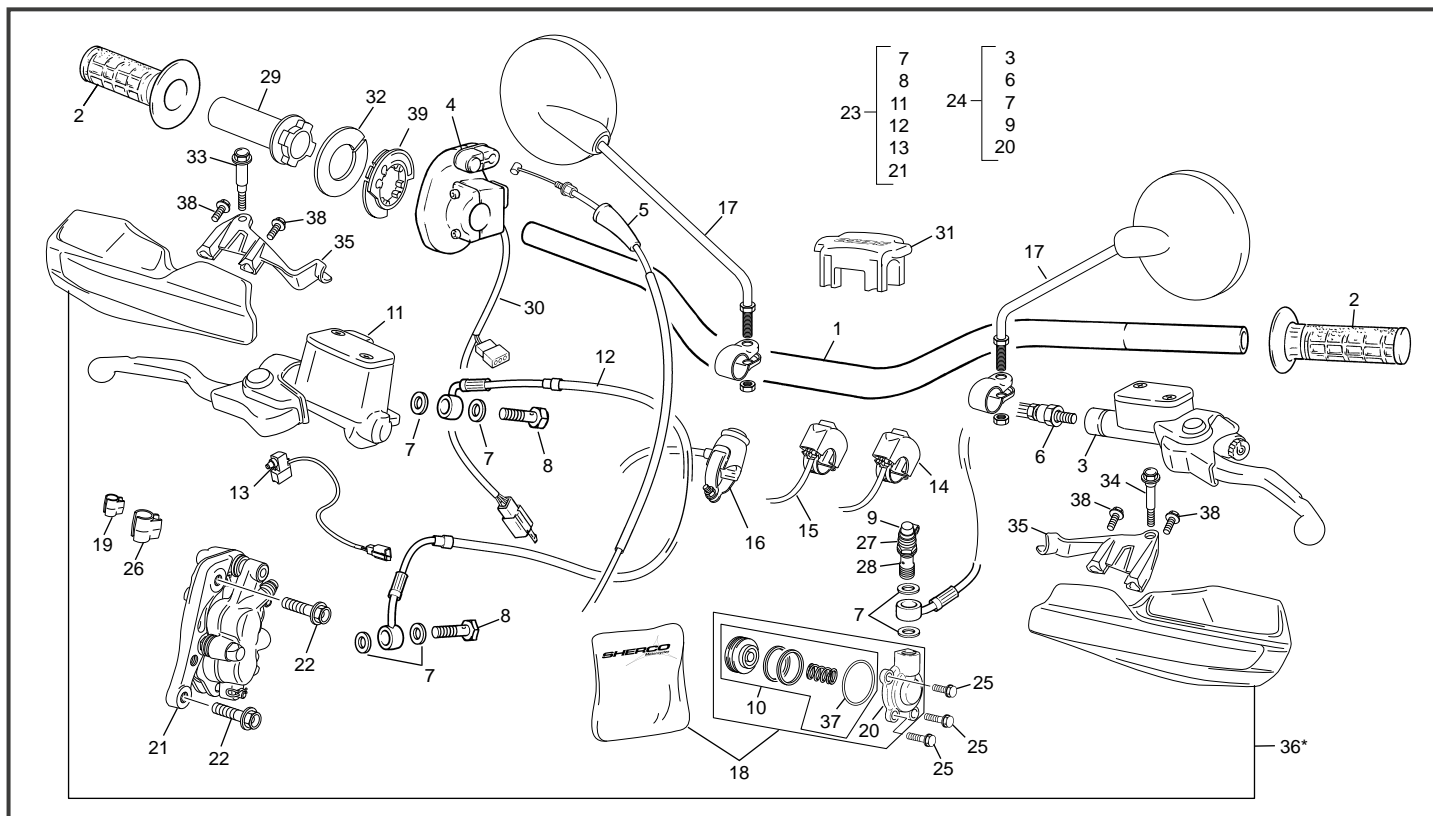

POS.	125 SE-R	FRANÇAIS	ENGLISH	ESPAÑOL
36	6748*	PARES MAINS BLANC JEU	HAND GUARD WHITE SHERCO	PARA MANO BLANCO JUEGO SHERCO
37	3643	JOINT TORIQUE 31.5X35.5X2	O RING 31.5X35.5X2	TORICA 31.5X35.5X2
38	3555	VIS PLASTIQUE DELTA 5 X18	PLASTIC SCREW 5 X18	TORNILLO PLASTIC 5X18
39	10103	CAME DE GAZ 2T	CAM REEL 2T	ANILLO DE GAS DE CONTROL 2T

* NOUVELLE PIECE
NEW PART
PIEZA NUEVA

Plastiques Plastics / Plásticos

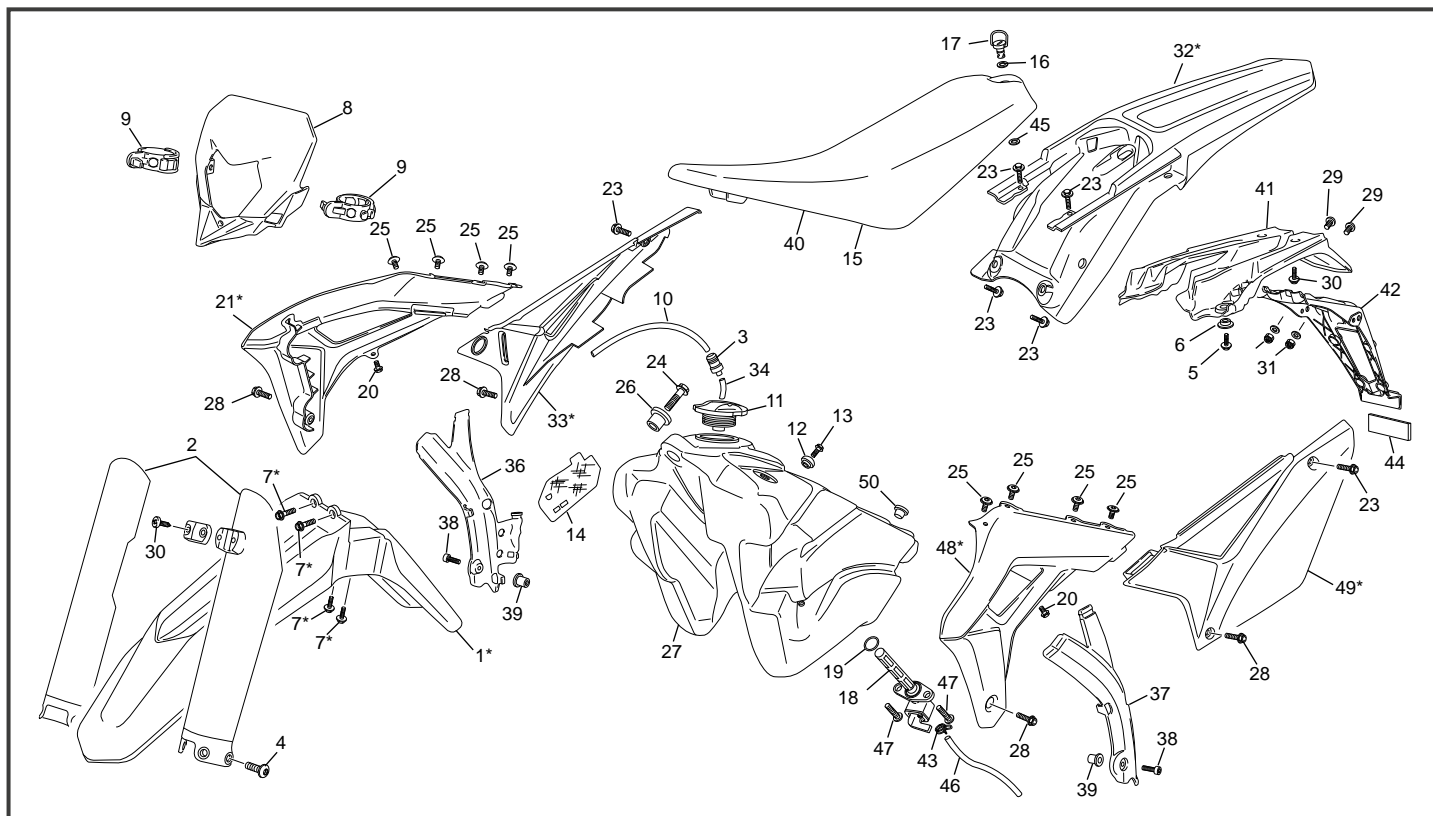

POS.	125 SE-R	FRANÇAIS	ENGLISH	ESPAÑOL
1	6383*	PARE BOUE AVANT BLEU	BLUE FRONT MUGUARD	GUARDABARRO DELANTERO AZUL
2	6755	PROTECTEUR FOURCHE	LEFT FORK PROTECTOR	PROTEC. HORQUILLA
3	5725	CLAPET ESSENCE	PETROL VALVE	VÁLVULA DE GASOLINA
4	6757	VIS SPECIALE PROTECTEUR FOURCHE	FORK PROTECTOR BOLT	TORNILLO ESPECIAL PROT. HORQUILLA
5	0546	VIS THEP M6 X 20	SCREW THEP M6 X 20	TORNILLO THEP M6 X 20
6	3097	ENTRETOISE 2 INOX CARROSSERIE	SPACER 2 INOX BODY	CASQUILLO 2 INOX CARROCERIA
7	8601*	VIS TH EP 6 X 20 EPAULE	SREW TH EP 6 X 20 SPECIAL	TORNILLO TH EP 6 X 20 SPECIAL
8	3065	PLAQUE PHARE	FRONT LIGHT	PLACA FARO
9	H050	ELASTIQUE PLAQUE PHARE	HEADLIGHT RUBBER MOUNT	ELÁSTICO PLAÇA FARO
10	0252	DURITE MISE A L'AIR 350MM	FUEL LINE 350MM	TUBO RESPIRADERO 350MM
11	H398	BOUCHON ESSENCE	FUEL TANK CAP	TAPÓN GASOLINA
12	0497	FIXATION SELLE RESERVOIR	SPACER SEAT /TANK	CASQUILLO SILLÍN DEPÓSITO
13	0652	VIS FHC M6X25	SCREW FHC M6X25	TORNILLO AVELLANADO M6 X 25
14	6684	PROTECTION THERMIQUE	THERMAL PROTECTION	PROTECCIÓN TERMICA
15	6971	SELLE	SEAT	SILLÍN
16	0532	RONDELLE PLASTIQUE DZUS	PLASTIC WASHER DZUS	ARANDELA PLÁSTICO DZUS
17	6685	DZUS DE SELLE	DZUS FASTENER	CIERRE SILLÍN
18	7598	ROBINET ESSENCE	FUEL TAP	GRIFO DE GASOLINA
19	5146	JOINT TORIQUE ROBINET	FUEL TAP O-RING	JUNTA DEL GRIFO DE GASOLINA
20	5201	VIS THEP M6X16	SCREW M6X16	TORNILLO M6X16
21	8607*	OUIE DROITE IPD *21	RADIATOR SIDE PANEL R IPD *21	PLACA RADIADOR I DERE IPD *21
23	1366	VIS BHC M6 X 8	SCREW BHC M6 X 8	TORNILLO BHC M6 X 8
24	0547	VIS THEP M6 X 30	SCREW THEP M6 X 30	TORNILLO THEP M6 X 30
25	6812	VIS M6 X 8	SCREW M6 X 8	TORNILLO M6 X 8
26	3349	SILENTBLOC RÉSERVOIR	TANK SILENT BLOC	SILENTBLOC DEL DEPÓSITO
27	7482	RÉSERVOIR D'ESSENCE	FUEL TANK	DEPÓSITO DE GASOLINA
28	5200	VIS THEP M6 X 20	SCREW THEP M6 X 20	TORNILLO THEP M6 X 20
29	3679	VIS BHC E M6 X 20	SCREW BHC E M6 X 20	TORNILLO BHC E M6 X 20
30	3555	VIS PLASTIQUE M5 X 18	PLASTIC SCREW M5 X 18	TORNILLO POR PLASTICO M5 X 18
31	2086	ECROU À EMBASE M6	COLLAR HEX NUT FLAT M6	TUERCA CON VALONA M6
32	7304*	PARE BOUE ARRIERE BLEU	BLUE BACK MUDGUARD	GUARDABARO TRASERO AZUL
33	8608*	PLAQUE LATERALE DROITE IPD *21	SIDE NUMBER PLATE R IPD *21	PLACA NO DER AZUL. BLANCA IPD *21
34	5585	DURITE 35MM	FUEL HOSE 35MM	TUBO GASOLINA 35MM
36	6618	PROT. DE CADRE DROITE	RIGHT FRAME PLASTIC PROT.	PROT. PLASTICO CHASIS DERECHA
37	3496	PROT. DE CADRE GAUCHE	LEFT FRAME PLASTIC PROT.	PROT. PLASTICO CHASIS IZQUIERDA

*Sherco se réserve les droits de modification des références, merci de contrôler sur le portail Sherconetwork avant toute commande. - *Sherco reserves the right to make change on the references, please check on your Sherconetwork portal before ordering.
*Sherco se reserva el derecho para hacer modificaciones sobre las referencias. Por favor, verifica en el Sherconetwork antes de hacer un pedido.

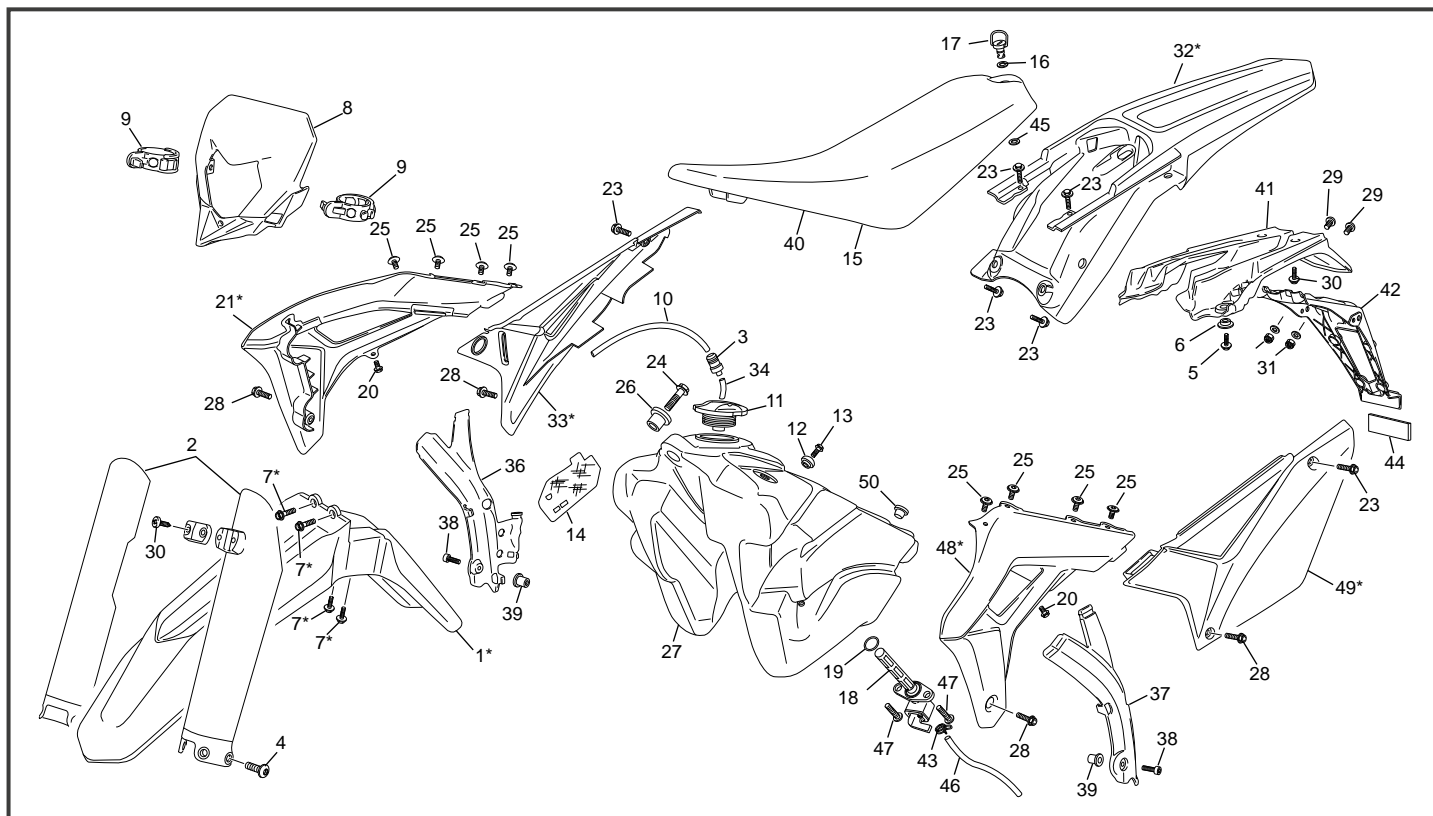

POS.	125 SE-R	FRANÇAIS	ENGLISH	ESPAÑOL
38	3880	VIS BHC E M5X30	SCREW BHC E M5X30	TORNILLO BHC E M5X30
39	3793	WELL NUT	WELL NUT	SILEMBLOCK
40	7206	HOUSE DE SELLE	SLEENE SET	FUNDA ASIENTO
41	6512	SUPPORT FEUX ARRIÈRE	SUPPORT RERD LIGHT	SOPORTE FARO TRASERO
42	3549	SUPPORT PLAQUE IMMATRCULATION	SUPPORT NUMBER PLATE	SOPORTE PLACA MATRICULA
43	5410	COLLIER SERRAGE DOUBLE FIL	HOSE SEEGER	SEEGER TUBOS
44	1526	CATADIOPTRE ROUGE ARR.	RED REAR REFLECTOR	REFLECTOR TRASERO ROJO
45	6683	RONDELLE VEROUILLAGE DZUS	WASHER DZUS	ARANDELLA VEROUILLAGE
46	4634	DURITE ESSENCE	FUEL LINE	TUBO DE GASOLINA
47	2990	VIS CHC MSX12	SCREW CHC MSX12	TORNILLO CHC MSX12
48	8606*	OUIE GAUCHE IPD "21	RADIATOR SIDE PANEL L IPD "21	PLACA RADIADOR IZQU IPD "21
49	8609*	PLAQUE LATERALE GAUCHE IPD "21	SIDE NUMBER PLATE L IPD "21	PLACA NO IZQ AZUL BLANCA IPD "21
50	8567	BOUCHON FIXATION RESERVOIR	FUEL TANK CAP FIXING	TAPON DEPOSITO

* NOUVELLE PIECE
NEW PART
PIEZA NUEVA

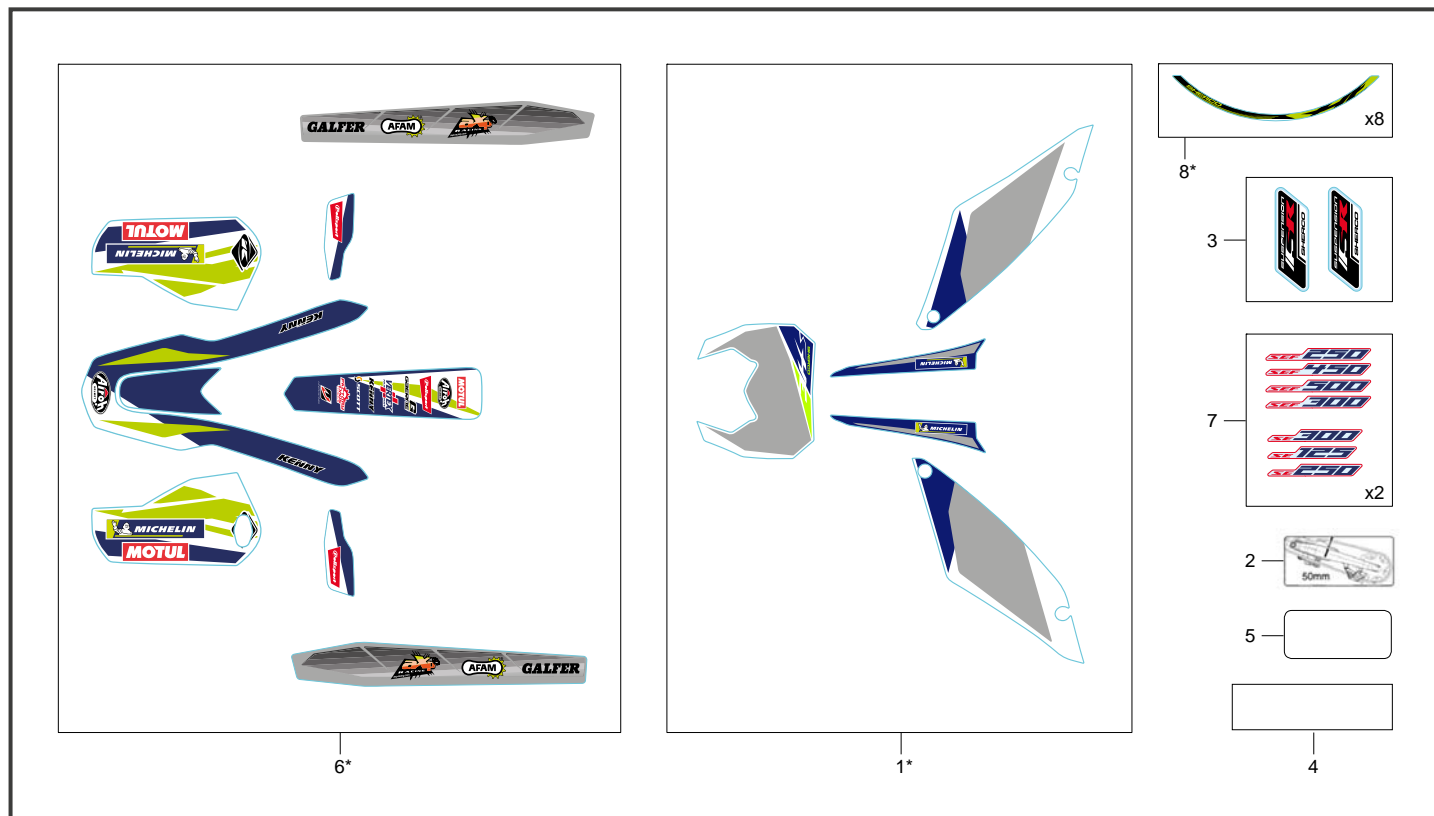

POS.	125 SE-R	FRANÇAIS	ENGLISH	ESPAÑOL
1	8718*	KIT ADHESIF PLAQUES NUMERO "21	NUMBER PLATE STICKER KIT "21	PLACA NUMERO KIT ADHESIVOS "21
2	3735	ADHÉSIF TENSION DE CHAÎNE	STICKER CHAIN TENSIONER	ADHESIVO TENSION DE CADENA
3	7777	ADH. PROTECTION DE FOURCHE	STICKER PROTECTION FORK	ADH. PROTECCIÓN HORQUILLA
4	4516	ADH. PROTECTION N°. SERIE CADRE	STICKER N°. FRAME PRETECTION	ADH. N°. DE PROTECCIÓN CHASSIS
5	5617	ADH. PROTECTION PLAQUE CONSTR.	STICKER CONSTR. PLATE PROTECTION	ADH. PLACA CONSTR. DE PROTECCIÓN
6	8603*	KIT ADHESIF PLAQUE BRAS PROTEC MAINS "21	NUMBER PLATE SWING ARM HAND GARD STICKER KIT "21	PLACA DE NÚMERO BASCULANTE PARAMANO KIT ADH. "21
7	8209	JEU ADHÉSIFS CYLINDRÉE "20	ADHESIVE KIT DISPLACEMENT "20	JUEGO ADHESIVOS CILINDRADA "20
8	8602*	KIT ADHESIF JANTE "21	ARM RIMS STICKER KIT "21	KIT ADHESIVOS "21 GUARDABARRO

* NOUVELLE PIÈCE
NEW PART
PIEZA NUEVA

Démarrreur Starter motor / Motor de arranque

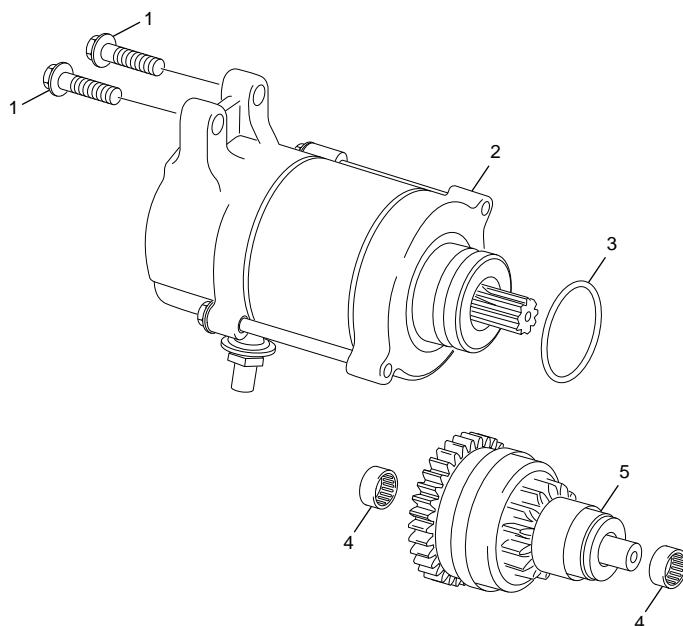

POS.	125 SE-R	FRANÇAIS	ENGLISH	ESPAÑOL
1	0554	VIS TH EP 5 X 20	SCREW THEP 5X20	TORNILLO TH EP 5 X 20
2	5880	DEMARREUR ELECTRIQUE 125 SE	STARTER MOTOR 125 SE	MOTOR ELECTRIC STARTER 125 SE
3	5197	JOINT TORIQUE 25 X 3VITON	O-RING 25X3	JUNTA TORICA CULATA 25 X 3 VITON
4	M029	ROULEMENT AIGUILLE POMPE EAU HK0808	NEEDLE BEARING HK0808	COJINETE AGUJAS BOMBA AGUA HK 0808
5	5881	ENSEMBLE LANCEUR SM10-234	BENDIX 125 SE	LANZADOR DE ARRANQUE SM10-234

Selecteur Gear selector group / Selector cambio

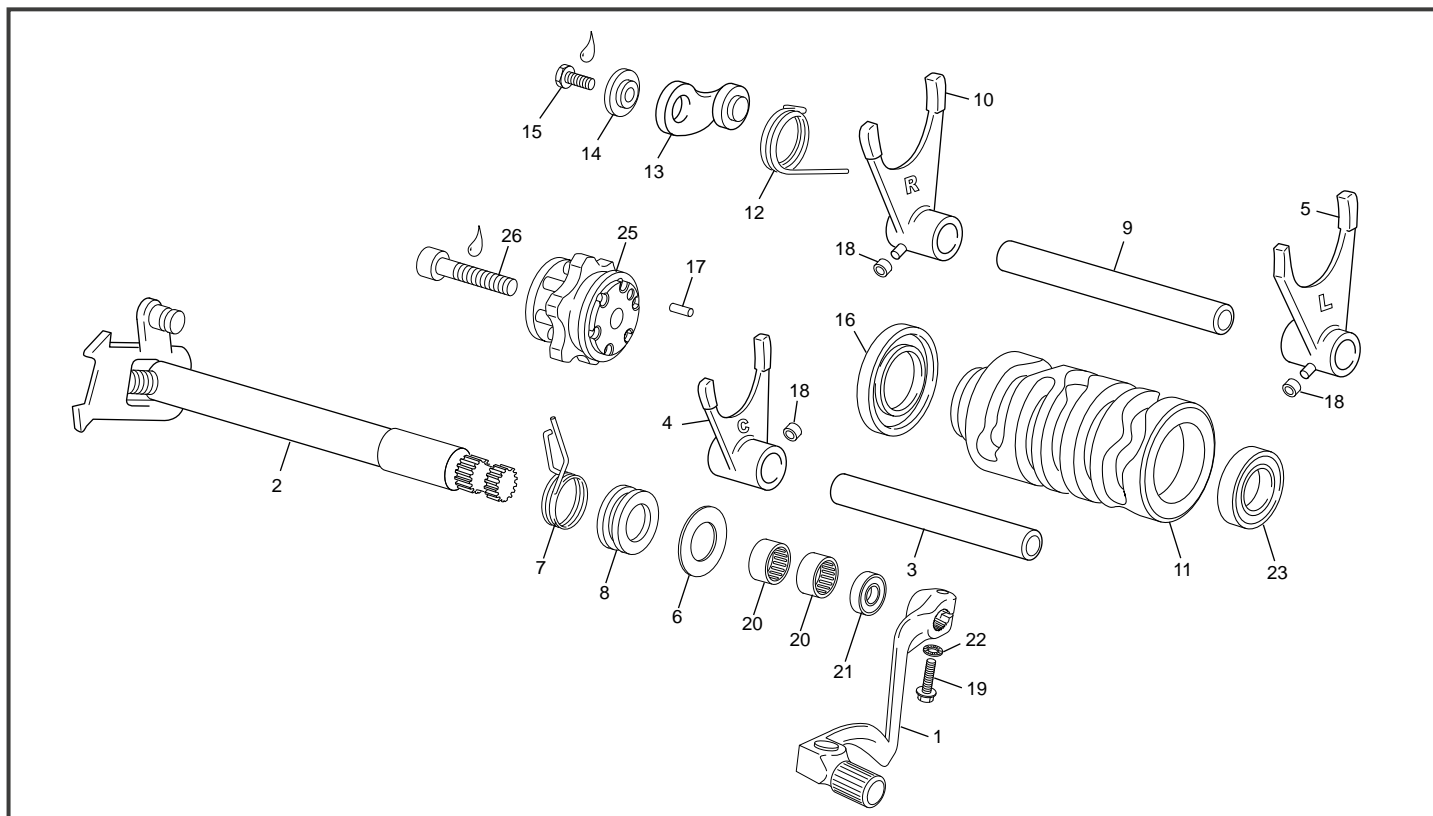

POS.	125 SE-R	FRANÇAIS	ENGLISH	ESPAÑOL
1	3889	SELECTEUR ALU CPL 250 2T END	ALUMINIUM SELECTOR	PALANCA CAMBIO 250 2T END
2	5064	AXE DE SELECTEUR COMPLET 250 END	GEAR SELECTOR AXLE	ARBOL SELECTOR CILINDRICO 250 END
3	1019	AXE DE FOURCHETTE 250 END	FORK AXLE	EJE HORQUILLA 90 MM 250 END
4	5891	FOURCHETTE 5/6 125 SE	FORK 5/6 125 SE	HORQUILLA 5/6 125 SE
5	5893	FOURCHETTE 2/4 125 SE	FORK 2/4 125 SE	HORQUILLA 2/4 125SE
6	5667	RONDELLE 14 X 28 X0.5	WASHER 14 X 28 X 1	ARANDELLA 14 X 28 X 0.5
7	0208	RESSORT RAPPEL SELECTEUR END	SELECTOR SPRING	MUELLE SELECTOR
8	0209	DOUILLE RESSORT SELECTEUR END	SELECTOR SPRING SPACER	CASQUILLO MUELLE SELECTOR END
9	1018	AXE DE FOURCHETTE 100MM 250 END	FORK AXLE 100 MM	EJE HORQUILLA 100MM 250 END
10	5892	FOURCHETTE 1/3 125 SE	FORK 1/3 125 SE	HORQUILLA 1/3 125 SE
11	5889	BARILLET DE SELECTION 125 SE	SELECTION DRUM 125 SE	DESMODRONICO SELECTOR 125 SE
12	0210	RESSORT RAPPEL VEROUILLAGE END	INDEX LEVER SPRING	MUELLE BOOMERANG END
13	5142	DOIGT DE VEROUILLAGE CPL END EVO	INDEX LEVER ASSY	PALANCA CIERRE SELECTOR 450 END EVO
14	M321	RONDELLE 6 X 18 X 1.5 0411	INDEX LEVER WASHER	ARANDELA 6 X 18 DIN 9021
15	M249	VIS CHC TETE BASSE 6 X 20 TROU GUIDAGE	SCREW TH EP 6 X 20	TORNILLO M 6 X 20 CABEZA REBAJADA
16	0868	ROULEMENT 61905 DE BARILLET 250 END	BEARING 6905	RODAMIENTO 61905 DE TAMBOR 250 END
17	0101	AIGUILLE NRB X 3 X 11.8	NEEDLE NRB 3X11,8	AGUJAS X 3 X 11.8
18	1015	ROULEAU FOUCHETTE 250 END	FORK SPACER	ANILLO HORQUILLA 250 END
19	0546	VIS TH EP 6 X 20	SCREW TH EP 6 X 20	TORNILLO TH EP 6 X 20
20	0527	DOUILLE AIGUILLE HK 1412	NEEDLE BEARING	CASQUILLO AGUJAS HK14 12
21	0660	JOINT LEVRE DOUBLE 14X24X6	LIP SEAL 14X24X6	RETEN 14X24X6 NITRILE DOUBLE L METAL
22	0746	RONDELLE AET 6	WASHER AET 6	ARANDELA AET6
23	3807	ROULEMENT 6001-2RSL/LHT23	BEARING 6001 2RS	COJINETE 6001 2RS
25	5888	ETOILE DE SELECTION 125 SE	SELECTION 125 SE	LOCATING DRUM 125 SE
26	1721	VIS CHC 6 X 30 TETE BASSE ZI BLANC 8.8	SCREW CHC 6 X 30 DIN 7984	TORNILLO CHC 6 X 30 TETE BASSE ZI

Boîte a vitesses Gear set / Cambio

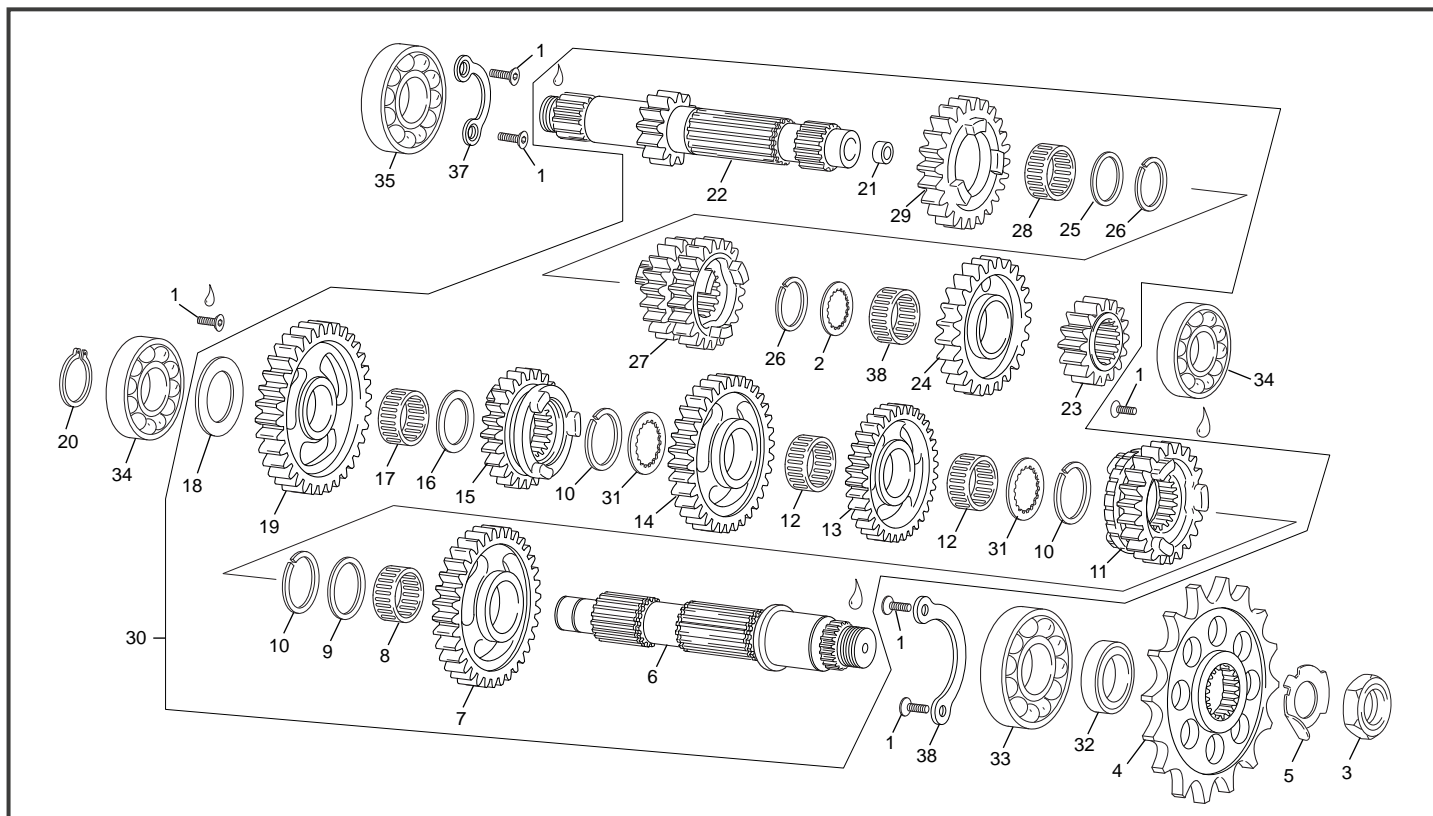

POS.	125 SE-R	FRANÇAIS	ENGLISH	ESPAÑOL
1	0872	VIS FHC M5 X 10 250 END DIN 7991	FHC SCREW M5 X 10 250 END DIN 7991	TORNILLO FHC M5 X10 250 END
2	1794	RONDELLE 19.5X27.8X1 250 END	WASHER 19.5X27.8X1 250 END	ARANDELLA CIGUENAL 19.5X27.8X1 250 END
3	0994	ECROU M18 X 100	NUT M18 X 100	TUERCA M 18 X 100
4	1007	PIGNON SORTIE DE BOITE Z14 250 END	CHAIN SPROCKET Z14	PINON CADENA Z14 250 END
4	1012	PIGNON SORTIE DE BOITE Z 13 250 END	CHAIN SPROCKET Z13 (STD)	PINON CADENA Z13 250 END
5	3463	RONDELLE PIGNON SORTIE DE BOITE END	CHAIN SPROCKET WASHER	ARANDELA PINON CADENA 250/300 END
6	1775	ARBRE SECONDAIRE END 250	GEARBOX SECONDARY AXLE	EJE SECUNDARIO END 250
7	7219	PIGNON SECONDAIRE 2 EME Z31	GEAR Z31 2ND	PINION SECOND 2 EME Z31
8	1778	BAGUE A AIGUILLE 24X28X10 250 END	NEEDLE BEARING 24X28X10	CASQUILLO DE AGUJA 24X28X10 250 END
9	1779	RONDELLE 24.2X32X1.5 250 END	WASHER 24.2X32X1.5	ARANDELLA 24.2X32X1.5 250 END
10	1780	CIRCLIP SW 23	CIRCLIP SW 23	CIRCLIP SW 23
11	1781	PIGNON 5 Z22 250 END	GEAR Z22 5TH	PINON 5 Z22 250 END
12	1782	BAGUE A AIGUILLE K20X24X10 250 END	NEEDLE BEARING K20X24X10	CASQUILLO DE AGUJA K20X24X10 250 END
13	5062	PIGNON 4 Z26 250 END	GEAR Z26 4TH	PINON 4 Z26 250 END
14	2331	PIGNON 3 Z23 250 END/MX EVO	GEAR Z23 3RD	PINON 3 Z23 250 END/MX EVO
15	1784	PIGNON 5 Z24 250 END	GEAR Z24 5TH	PINON 5 Z24 250 END
16	1787	RONDELLE 18.2X28X1.5 250 END	WASHER 18.2X28X1.5	ARANDELLA 18.2X28X1.5 250 END
17	3366	CAGE A AIGUILLE K18X22X10:	NEEDLE BEARING K18X22X10	COJINETE AGUJAS K18X22X10:
18	1788	RONDELLE 17X28X1.5 250 END	WASHER 17X28X1.5	ARANDELLA CIGUENAL 17X28X1.5 250 END
19	7220	PIGNON SECONDAIRE 1 ERE Z34	GEAR Z34 1ST	PINION SECOND 1 ERE Z34
20	M171	SEGMENT ARRET DIAM 17	CIRCLIP DIAM 17	SIGER DIAMETRO 17
21	1790	BAGUE BRONZE END 250	BRONZE RING	CASQUILLO BRONZE END 250
22	7221	ARBRE PRIMAIRE 125 SE	PRIMARY AXLE 125 SE	EJE PRIMARIO 125 SE
23	7222	PIGNON PRIMAIRE 2 EME Z17	GEAR Z17 2ND	PINION PRIMAIRE 2 EME Z17
24	1793	PIGNON 6 Z25 250 END	GEAR Z25 6TH	PINON 6 Z25 250 END
25	1794	RONDELLE 19.5X27.8X1 250 END	WASHER 19.5X27.8X1	ARANDELLA CIGUENAL 19.5X27.8X1 250 END
26	1795	CIRCLIP SW 21	CIRCLIP SW 21	CIRCLIP SW 21
27	1796	PIGNON 3/4 Z19/21 250 END	GEAR Z19/21 3RD/4TH	PINON 3/4 Z19/21 250 END
28	1797	BAGUE A AIGUILLE 22X26X10 250 END	NEEDLE BEARING 22X26X10	CASQUILLO DE AGUJA 22X26X10 250 END
29	5061	PIGNON 5 Z23 250 END	GEAR Z23 5TH	PINON 5 Z23 250 END
30	5886	BOITE A VITESSE CPL 125 SE	COMPLETE GEARBOX 125 SE	CTO CAMBIO 125 SE
31	1799	RONDELLE 21.5X31X1 250 END	WASHER 21.5X31X1	ARANDELLA 21.5X31X1 250 END
32	5849	JOINT LEVRE 25X38X7	SEALING 25X38X7	RETEN CIGUENAL 25X38X7
33	0174	ROULEMENT BILLE 6205 C3	BEARING 6205 C3	COJINETE 6205 C3
34	0875	ROULEMENT 6003-2RS1TN9/C3	BEARING 6003-2RS1TN9/C3	COJINETE 6003-2RS1TN9/C3

*Sherco se réserve les droits de modification des références, merci de contrôler sur le portail Sherconetwork avant toute commande. - *Sherco reserves the right to make change on the references, please check on your Sherconetwork portal before ordering.
*Sherco se reserva el derecho para hacer modificaciones sobre las referencias. Por favor, verifica en el Sherconetwork antes de hacer un pedido.

Boîte a vitesses Gear set / Cambio

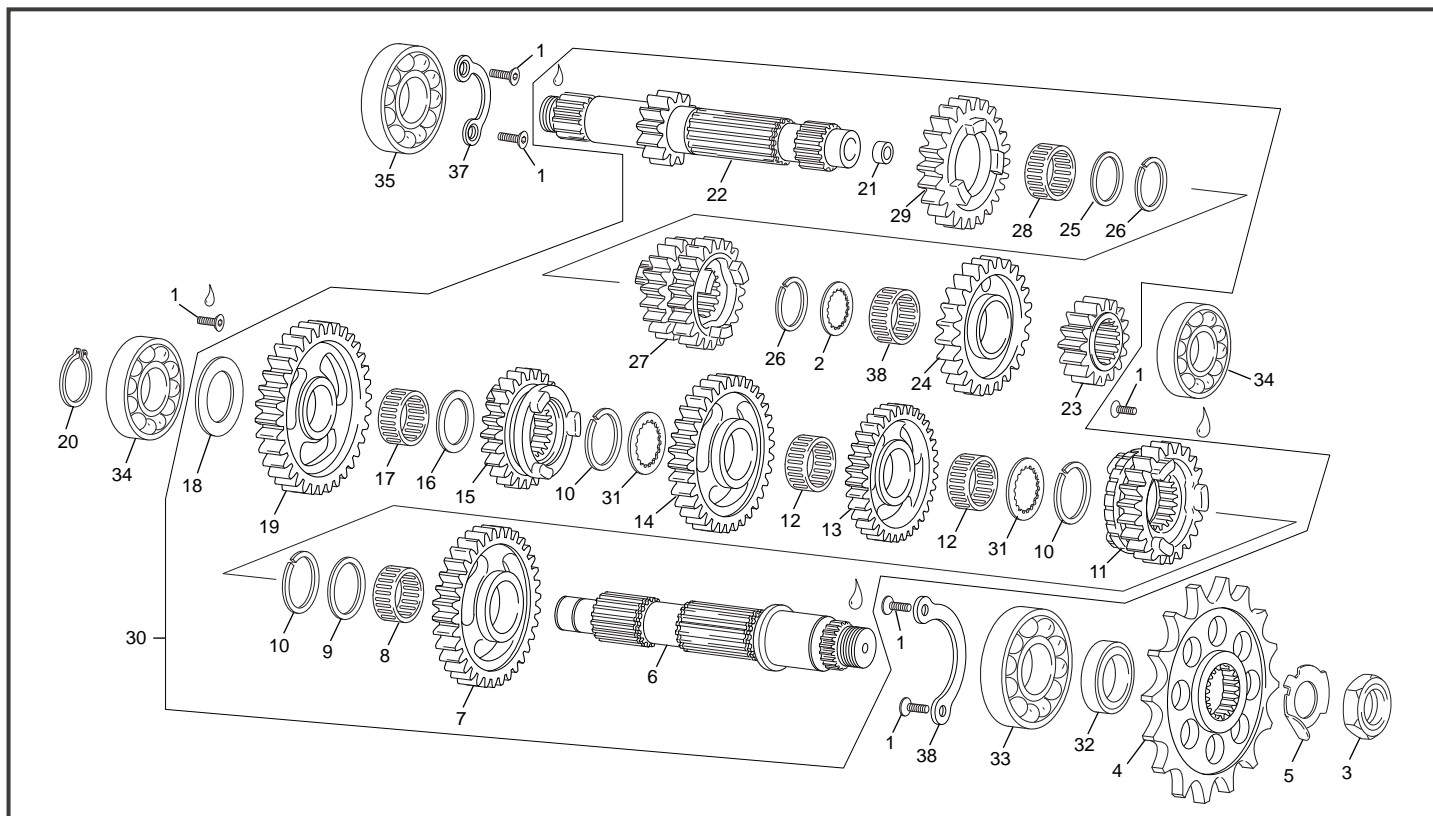

POS.	125 SE-R	FRANÇAIS	ENGLISH	ESPAÑOL
35	0876	ROULEMENT 6222 250 END	BEARING 6222	COJINETE 6222 250 END
37	7063	PLAQUE MAINTIEN RLT END 125 COTE EMB	BEARING HOLDING PLATE 125 CLUTCH SIDE	TENIENDO PLACA RETENCION 125 SE EMBRAGE
38	7062	PLAQUE MAINTIEN RLT END 125 COTE ALL	BEARING HOLDING PLATE 125 IGNITION SIDE	PLACA SUJETACION RODAMIENTO 125

Groupe carters Crankcase assembly / Grupo carters

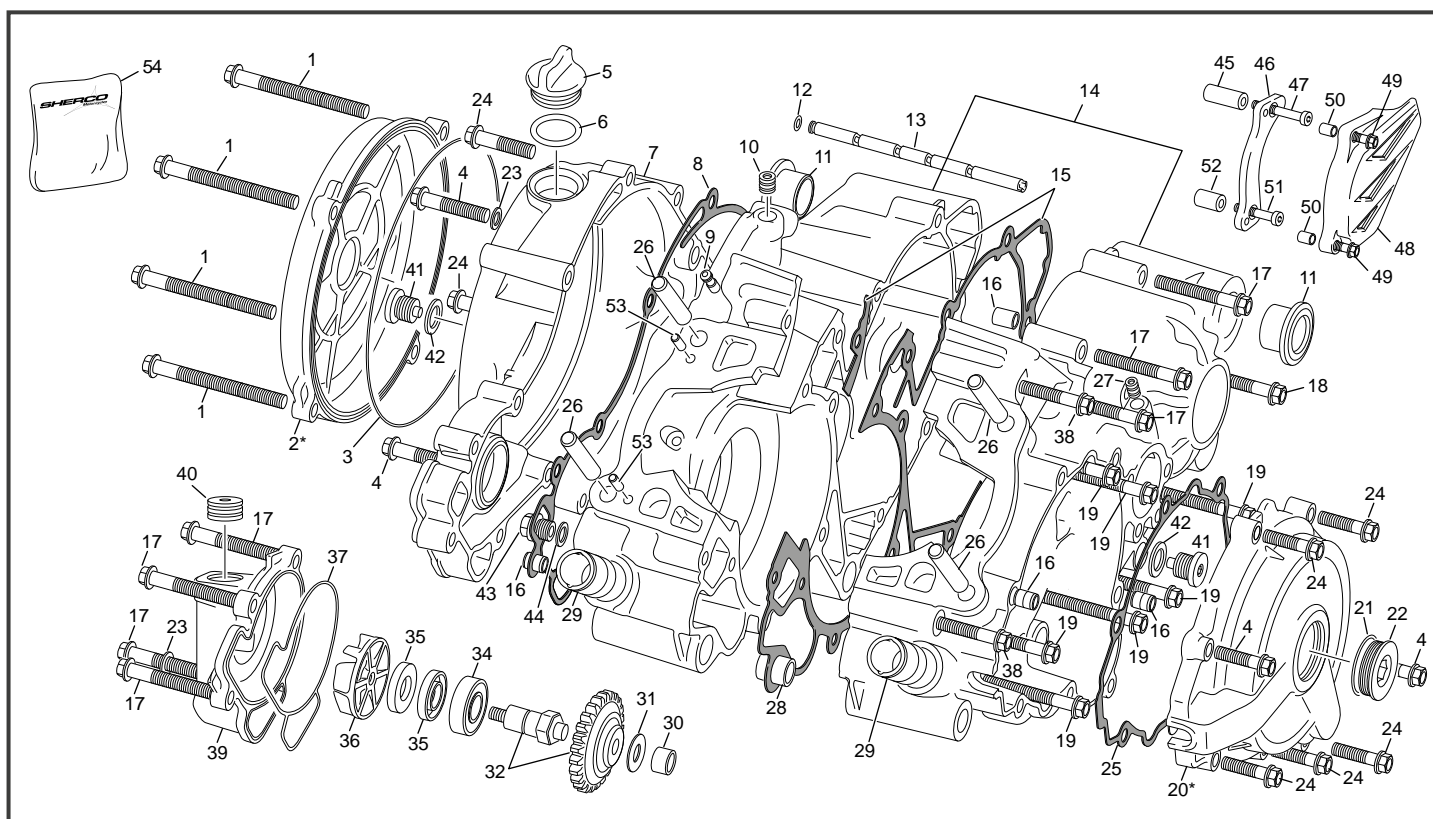

POS.	125 SE-R	FRANÇAIS	ENGLISH	ESPAÑOL
1	3826	VIS TH EP 6 X 70	TH EP SCREW 6 X 70	TORNILLO TH EP 6 X 70
2	2378*	COUVERCLE D EMBRAYAGE INJECTE	INJECTED CLUTCH COVER	TAPA EMBRAGUE INYECTADA
3	0989	JOINT DE COUVERCLE D' EMBRAYAGE 250 END	CLUTCH COVER O-RING	JUNTA TAPA EMBRAGUE 250 END
4	0547	VIS TH EP 6 X 30	TH EP SCREW 6 X 30	TORNILLO TH EP 6 X 30
5	0509	BOUCHON 24 HUILE END 450	OIL FILLING CAP	TAPON 24 END 450
6	0606	JOINT TORIQUE 19 X3	O-RING 19 X3	TORICA 19 X 3
7	5843	CARTER D EMBRAYAGE 125 SE	CLUTCH CRANKCASE 125 SE	CARTERS TAPAS EMBRAGUE 125 SE
8	5844	JOINT CARTER D EMBRAYAGE 125 SE	CLUTCH CRANKCASE GASKET 125 SE	JUNTA CARTER EMBRAGUE 125 SE FOAMET
9	4213	RENIFLAR CARTER CENTRAL END 250 2T	AIR VENT CENTRAL CRANKCASE	DEPRESOR CARTERS END 250 2T
10	1675	RIVET BOUCHON 8 MM	SEALING BUSH 8 MM	REMACHE 8 MM
11	1106	BAGUE CARTER 450 510	COLLAR BUSH	MANGUITO CARTER 450 510
12	4221	JOINT TORIQUE 5,00 X 1.2 VITON	O-RING 5,00 X 1.2 VITON	TORICA 5,00 X 1.2 VITON
13	5896	TUBE LUBRIFICATION BOITE 125 SE	GEARBOX LUBRIFICATION TUBE 125 SE	TUBO ACEITE CAMBIO 125 SE
14	8092	GROUPE CARTERS CENTRAUX 125 SE CPL SAV	CENTRAL CRANKCASE 125 SE	JUEGO CARTERS CENTRALES 125 SE RECAMBIO
15	6623	JOINT DE CARTER CENTRAL 125 SE	CENTRAL CRANKCASE GASKET 125 SE	JUNTA CARTER CENTRAL 125 SE FOAMET
16	0008	DOUILLES CENTRAGE 8X6X11	CENTERING BUSH 8X6X11	CENTRADOR 8X6X11
17	0591	VIS TH EP 6 X 40	SCREW TH EP 6 X 40	TORNILLO TH EP 6 X 40
18	0550	VIS TH EP 6 X 55	TH EP SCREW 6 X 55	TORNILLO TH EP 6 X 55
19	3235	VIS TH EP 6 X 50 ZN NI TR	TH EP SCREW 6 X 50 ZN NI TR	TORNILLO TH EP M6 X50 ZN NI TR
20	4803*	CARTER D ALLUMAGE 125 SE	IGNITION COVER 125 SE	CARTER INCENDIDO 125 SE
21	M644	JT 23 X 2.5 BOUCHON FILTRE HUILE	O-RING 23 X 2.5 OIL FILTER CAP	JUNTA TORICA 23 X 2 TAPON FILTRO ACIETE TRIAL
22	6411	BOUCHON CARTER SEF M27X100 EVO	IGNITION CRANKCASE PLUG	TAPON TAPA SEF M27X100 EVO
23	2390	RONDELLE CUIVRE 6 X 12 X 1.5 UNITAIRE	COPPER WAHSER M6X12	ARANDELA COBRE 6 X 12 X 1.5 UNIDAD
24	0970	VIS TH EP 6 X 25	SCREW THEP M6X25	TORNILLO TH EP M6 X 25
25	5845	JOINT CARTER ALLUMAGE 125 SE	IGNITION COVER GASKET	JUNTA CARTER ENCENDIDO 125 SE
26	M291	GOIJON DE CYLINDRE 8 X 46	STUD M8X30	ESPARRAGO CILINDRO 8 X 46
27	2386	BOUCHON CANALISATION HUILE 6X8	PLUG M6	TAPA CANALIZACION 6X8
28	0006	DOUILLES CENT CARTERS 14X11X16	CENTERING BUSH 14X11X16	CASQUILLO CARTER CENTRAL DEL 14X11X16
29	0464	RACCORD CYLINDRE/DURITE END	WATER PIPE COUPLING	CONECTOR TUBO AGUA CILINDRO END
30	M029	ROULEMENT AIGUILLE POMPE EAU HK0808	NEEDLE BEARING HK0808	COJINETE AGUJAS BOMBA AGUA HK 0808
31	6889	RONDELLE CALAGE POMPE A EAU 125 SE	WATER PUMP WASHER 125 SE	ARANDELA 19X8.3X0.5 POMPA AGUA
32	7460	AXE POMPE A EAU PIGNON 125 SE COMPLET	WATER PUMP AXLE 125 SE COMPLETE	EJE BOMBA AGUA PIÑON 125 SE JUEGO
34	3807	ROULEMENT 6001-2RSL/LHT23	BALL BEARING 6001-2RSL	COJINETE 6001 2RS
35	6071	JOINT LEVRE 12 X 24 X 4.5 BAL PRESSION	OIL SEAL 12 X 24 X 4.5 BAL PRESSION	RETEN 12 X 24 X 4.5 BAL PRESSION
36	0936	ROTOR DE POMPE A EAU 250 END	WATER PUMP ROTOR	ROTOR BOMBA AGUA 250 END

*Sherco se réserve les droits de modification des références, merci de contrôler sur le portail Sherconetwork avant toute commande. - *Sherco reserves the right to make change on the references, please check on your Sherconetwork portal before ordering.
*Sherco se reserva el derecho para hacer modificaciones sobre las referencias. Por favor, verifica en el Sherconetwork antes de hacer un pedido.

Groupe carters Crankcase assembly / Grupo carters

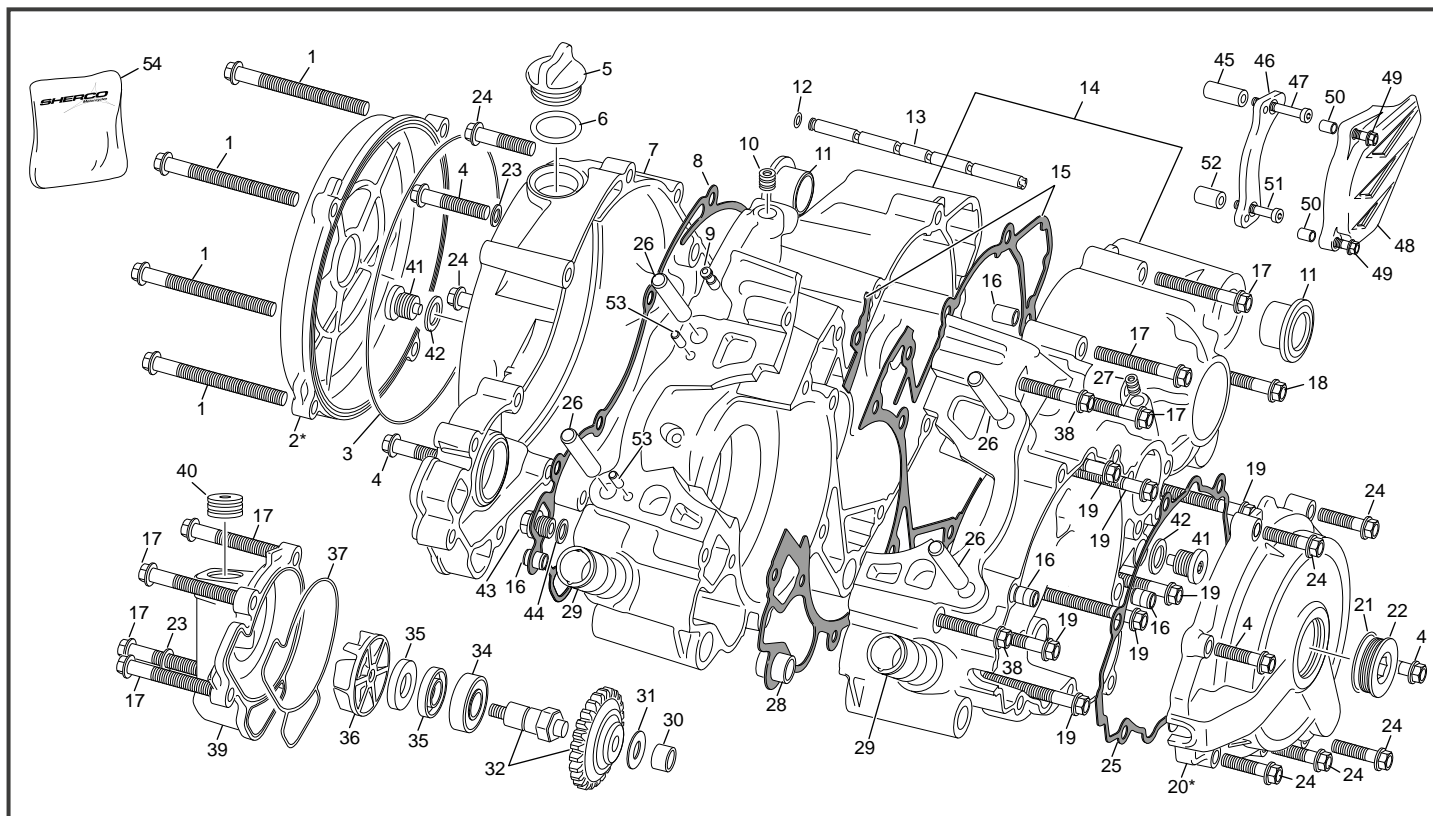

POS.	125 SE-R	FRANÇAIS	ENGLISH	ESPAÑOL
37	5846	JOINT COUVERCLE DE POMPE A EAU 125 SE	WATER PUMP COVER GASKET	JUNTA TAPA BOMBA AGUA 125 SE
38	0551	VIS TH EP 6 X 60	TH EP SCREW 6 X 60	TORNILLO TH EP 6 X 60
39	4809	COUVERCLE DE POMPE A EAU 125 SE	WATER PUMP COVER 125 SE	TAPA BOMBA AGUA 125 SE
40	3835	BOUCHON POMPE EAU 18.5 250 2T END	WATER PUMP COVER PLUG 18.5	TAPON BOMBA DEL AGUA 18.5 250 2T END
41	6927	BOUCHON MAGNETIQUE M12X1.5	MAGNETIC SCREW M12X1.5	TAPON MAGNETIC M 12
42	0610	RONDELLE CUIVRE 12 X 18 X 1.5 END 450	COPPER WASHER 12 X 18 X 1.5	ARANDELA CU 12 X 18 X 1.5 END 450
43	0855	BOUCHON TSC/FOM 10 X 1 VILO 250 END	TSC/FOM PLUG 10 X 1	TAPON TSC/FOM 10 X 1 250 END
44	1661	RONDELLE ALU 10 X 14 X 1.5 END 250	ALU WASHER 10 X 14 X 1.5	ARENDELLA ALU 10 X 14 X 1.5 END 250
45	6929	ENTRETOISE CARTER DE CHAINE SUP 125 SE	UPPER BUSH SPROCKET PROTECTOR 125 SE	CASQUILLO TAPON CADENA SUPERIOR 125 SE
46	6928	PROTECTEUR PIGNON CHAINE 125 SE	SPROCKET PROTECTOR SUPPORT	PROTECTOR PINON CADENA 125 SE
47	6932	VIS CHC M6 X 45 DIN 7984 8.8	CHC SCREW M6 X 45 DIN 7984 8.8	TORNILLO CHC M6 X 35 DIN 7984 8.8
48	0538	CARTER PIGNON SORTIE DE BOITE END 450	SPROCKET PROTECTOR	CARTER PROTECTOR PINION CADENA END 450
49	0548	VIS TH EP 6 X 35	TH EP SCREW 6 X 35	TORNILLO TH EP 6 X35
50	0008	DOUILLES CENTRAGE 8X6X11	CENTERING BUSH 8X6X11	CENTRADOR 8X6X11
51	6931	VIS CHC M6 X 35 DIN 7984 8.8	CHC SCREW M6 X 35 DIN 7984 8.8	TORNILLO CHC M6 X 35 DIN 7984 8.8
52	6930	ENTRETOISE CARTER DE CHAINE INF 125 SE	LOWER BUSH SPROCKET PROTECTOR 125 SE	CASQUILLO TAPON CADENA INFERIOR 125 SE
53	0200	AIGUILLE 4X9.8 NRB	NEEDLE 4X9.8 NRB	AGUJA 4X9.8 NRB
54	7309	KIT JOINT BAS MOTEUR 125 SE	KIT GASKET BOTTOM ENGINE 125 SE	KIT JUNTA MOTOR PARTE INFERIOR 125 SE

* NOUVELLE PIECE
NEW PART
PIEZA NUEVA

Vilebrequin assemble Crankshaft assembly / Cigüeñal biela

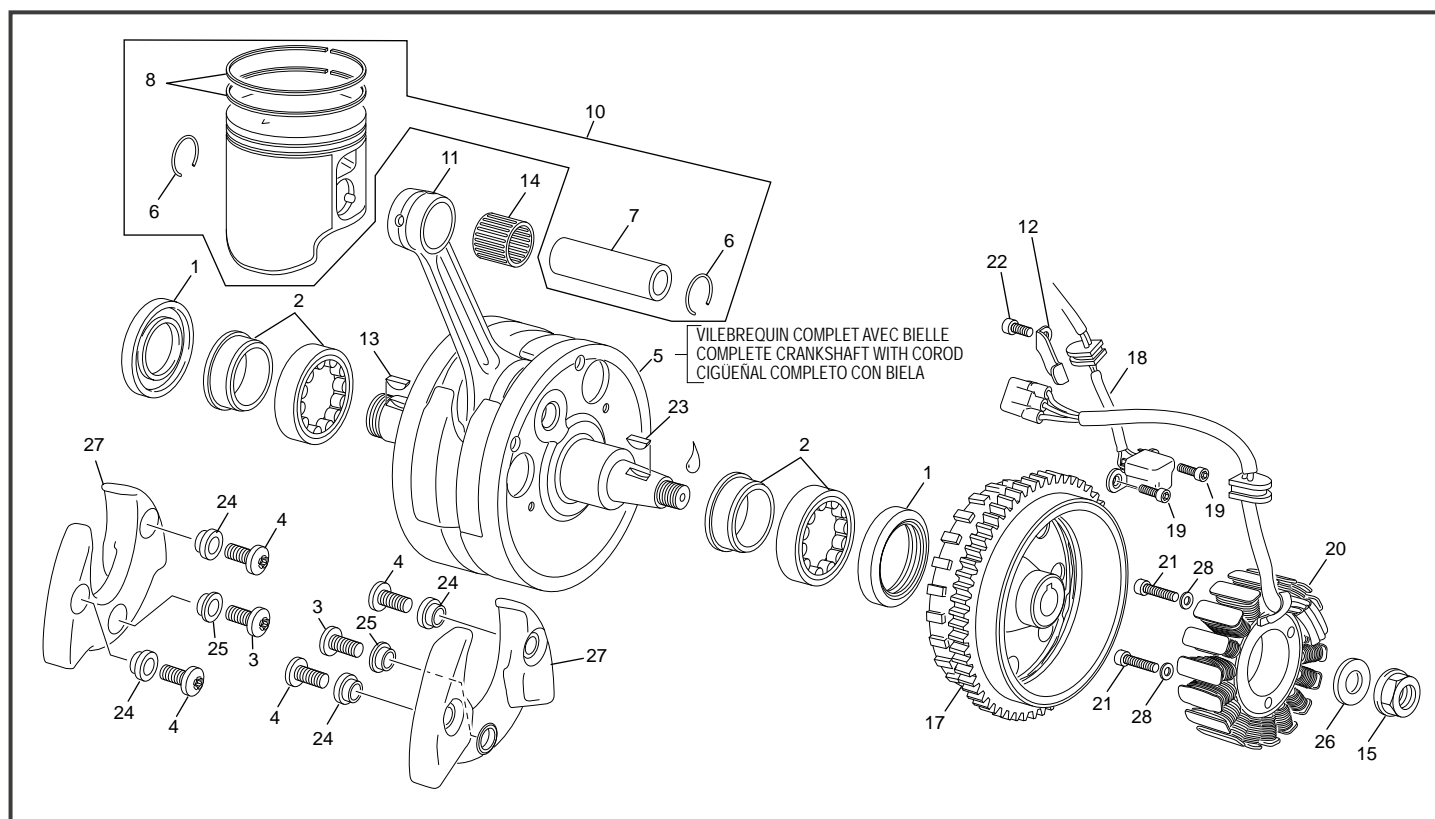

POS.	125 SE-R	FRANÇAIS	ENGLISH	ESPAÑOL
1	8369	JOINT LEVRE 25X38X7 CORPS ACIER	SEAL RING 25X38X7 STEEL BODY	RETEN CIGUEÑAL 25X38X7 CUERPO DE ACERO
2	1592	ROULEMENT ROULEAUX NJ206 EPC/C3	BEARING NJ206 EPC/C3 HVC 058	COJINETE ROLO NJ206 EPC/C3 HVC 058
3	7223	VIS TORX M6X12 125 SE.	SCREW M6X12 DIN 14593	TORNILLO CIGUEÑAL M6X12 125 SE
4	6881	VIS M6X16 DIN 14583	SCREW M6X16 DIN 14593	TORNILLO VIS M6 X16 DIN 14583
5	5852	VILEBREQUIN ASSEMBLE 125 SE	CRANKSHAFT ASSEMBLY 125 SE	CIGUEÑAL COMPLETO 125 SE
6	7224	CIRCLIPS PISTON 125 SE	PISTON CLIP 125 SE	SERCLIP PISTON 125 SE
7	4813	AXE DE PISTON 125 END 2T	PISTON AXLE 125 SE	BULON PISTON 125 END 2T
8	7225	SEGMENTS PISTON 125 SE JEUX	PISTON RING SET 125 SE	ARO PISTON 125 SE JUEGO
10	4812	PISTON CPL 125 SE A	PISTON CPL 125 SE "A"	PISTON CPL 125 SE A
10	6744	PISTON CPL 125 SE B	PISTON CPL 125 SE "B"	PISTON CPL 125 SE B
11	5853	KIT BIELLE 125 SE	CONROD KIT 125 SE	KIT BIELA 125 SE
12	3828	PLAQUE MAINTIEN FAISC. ALL. END	HOLDING WIRE PLATE	PLACA FIJACION HAZ 250 2T END
13	4224	CLAVETTE DEMI LUNE DM 13 T4	WOODRUF DM 13 T4	CHAVETA MEDIA LUNA DM 13 T4
14	7226	CAGE A AIGUILLE PISTON 125 SE	PISTON BEARING 125 SE	COJINETE DE AGUJAS 125 SE
15	1405	ECROU SPECIAL M12 X 1 250/450	NUT SPECIAL M12 X 1 250/450	TUERCA M12 X 1 250/450
16	----	FREIN FILET BLEU	THREAD LOCKER BLUE	AUTOBLOCANTE AZUL
17	7227	ROTOR ALLUMAGE 125 SE	ROTOR 125 SE	ROTOR 125 SE
18	5904	CAPTEUR VOLANT 125 SE	PICK UP SENSOR 125 SE	MOTOR ACTUATOR 125 SE
19	2990	VIS CHC MSX12 ZI	SCREW CHC MSX12 ZI	TORILLO CHC MSX12 ZI
20	5903	STATOR ALLUMAGE 125 SE	STATOR 125 SE	STATOR ENCENDIDO 125 SE
21	1029	VIS CHC M5 X 20	SCREW CHC M5 X 20	TORNILLO M5 X 20
22	1474	VIS CHC M4 X 8	SCREW CHC M4 X 8	TORNILLO M4X8 CHC
23	0055	CLAVETTE DEMI LUNE 3X5 13 DIN 6888	ROTOR WOODRUFF KEY	CHAVETA MEDIA LUNA 3X5 X13 DIN 6888
24	7229	ENTRETOISE VIS VILEBREQUIN EXT 125 SE.	EXTERNAL SCREW SPACER CRANKSHAFT	BRACE TORNILLO CIGUEÑAL 125 SE EXT
25	7230	ENTRETOISE VIS VILEBREQUIN INT 125 SE.	INNER SCREW SPACER CRANKSHAFT	BRACE TORNILLO CIGUEÑAL 125 SE INT
26	1963	RONDELLE CONIQUE 12.2 X 23 X 1	ROTOR CONICAL WASHER	ARANDELA CONIQUE 12.2 X 23 X 1
27	7228	MASELOTTE VILEBREQUIN 125 SE.	CRANKSHAFT MASS	GANCHETE CIGUEÑAL 125 SE
28	4751	RONDELLE SCHNORR M5 ZI	WASHER AET M5	RONDELLE SCHNORR M5 ZI

Embrayage Clutch / Embrague

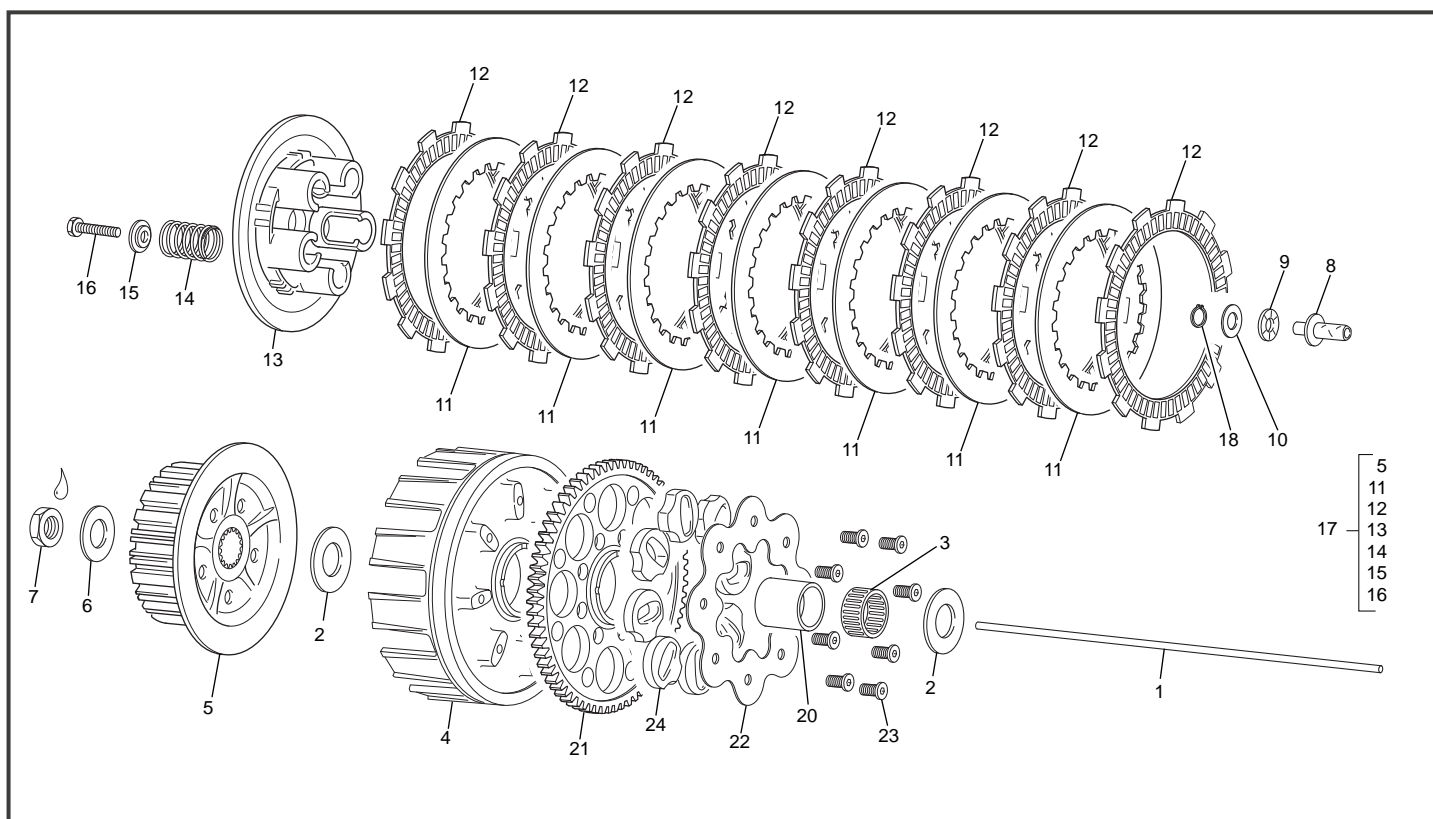

POS.	125 SE-R	FRANÇAIS	ENGLISH	ESPAÑOL
1	5905	TIGE DE POUSSEE ENB 125 SE	PUSH ROD CLUTCH 125	VARILLA EMB 125 SE
2	5887	RONDELLE EMBRAYAGE 125 SE	CLUTCH WASHER 125 SE	ARANDELA EMBRAGUE 1250SE
3	5885	DOUILLE AIGUILLE K 28X35X16	NEEDLE BEARING 28X35X16	CASQUILLO DE AGUJAS K 28X35X16
4	7281	KIT CLOCHE ALUMINIUM 125 SE	CLUTCH BASKET CPL 125 SE	KIT CAMPANA EMBRAGUE 125 SE
5	5821	NOIX D EMBRAYAGE 125 SE	CLUTCH HUB 125 SE	MAZA EMBRAGUE 125 SE
6	4876	RONDELLE FREIN EMBRAYAGE	CONICAL WASHER 18 X 35 X 2	ARANDELA FRENO EMBRAGUE 250/300 4T
7	0994	ECROU M18 X 100	NUT M18 X 100	TUERCA M 18 X 100
8	0983	BUTEE EMBRAYAGE 250 END	CLUTCH PUSHER 250 END	PULSADOR AXIAL 250 END
9	0997	BUTEE AIGUILLE AXK 821 250 END	NEEDLE STOP AXK 821 250 END	CORONA COJINETE ABUJAS AXK 821 250 END
10	0998	RONDELLE INA 8 X 21 X 1	INA WASHER 8X21X1	ARANDELA 8 X 21 X 1
11	0985	DISQUE METAL 250 END	DISC PLATE 250 END	DISCO EMBRAGUE METALICO 250 END
12	4923	DISQUE GARNI 250/300 END EVO	FRICTION DISC 250/300 END EVO	DISCO EMBRAGUE FORRADO 250/300 END EVO
13	0987	PLATEAU PRESSION 250 END	PRESSURE PLATE 250 END	PLATO DE PRESION 250 END
14	7231	RESSORT D` EMBRAYAGE 125 SE	CLUTCH SPRING 125 SE	MUELLE EMBRAGUE 125 SE
15	3293	RONDELLE 6 SPECIALE	WASHER 6 SPECIALE	ARANDELLA 6 ESPECIAL
16	0547	VIS TH EP 6 X 30	SCREW TH EP 6 X 30	TORNILLO TH EP 6 X 30
17	5747	EMBRAYAGE COMPLET 125 SE	COMPLETE CLUTCH 125 SE	EMBRAGUE COMPLETO 125 SE
18	0080	SEGMENT D` ARRET E 8	CIRCLIP E 8	SEGER E 8
20	5884	BAGUE EMBRAYAGE 125 SE	CLUTCH BUSHING	CASQUILLO EMBRAGE 125 SE
21	7047	PIGNON Z20 ET COURONNE Z72 PRIMAIRE 125 SE	PRIMARY GEARS Z20 ET Z72 125 SE	PIÑON PRIMARIA Z20 Y CORONA Z72 125 SE
22	7049	PLATEAU METAL 125 SE	STEEL DISK CLUTCH 125 SE	DISCO ACERO EMBRAGUE 125 SE
23	7713	VIS TETE PLATE M6X12	SPECIAL SCREW M6X12	TORNILLO M6X12
24	7048	SILENT BLOC EMBRAYAGE 125 SE	RUBBER CLUTCH 125 SE	SILENBLOC EMBRAGUE 125 SE

Cylindre-Culasse Cylinder-Cylinder head / Cilindro-Culata

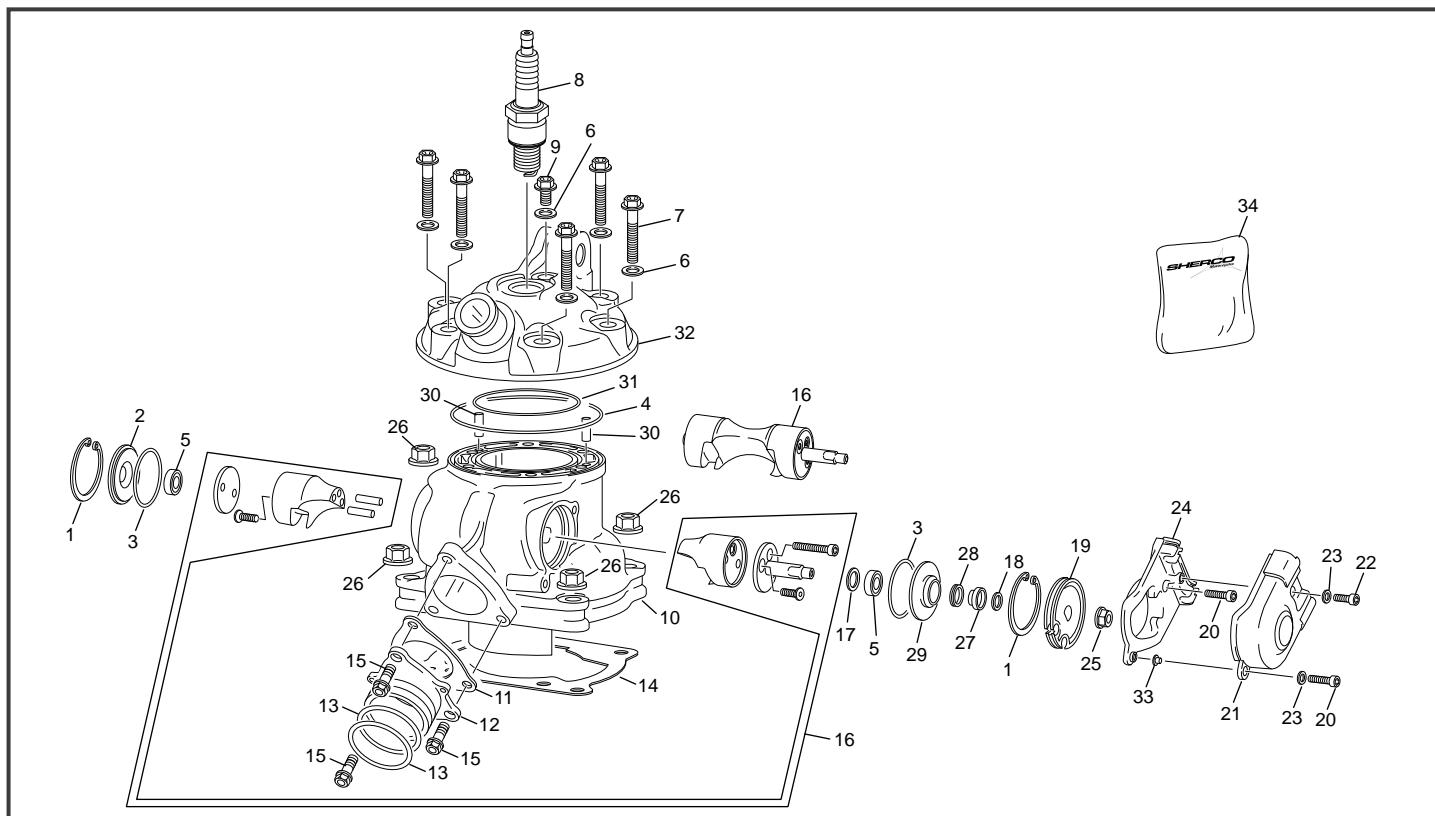

POS.	125 SE-R	FRANÇAIS	ENGLISH	ESPAÑOL
1	5878	CIRCLIP D 38 DIN 472	CIRCLIP D 38 DIN 472	CIRCLIP D 38 DIN 472
2	5872	COUVERCLE DE VALVE DROITE 125 SE	RIGHT VALVE COVER 125 SE	TAPA VALVULA DERECHA 125 SE
3	6886	JOINT TORIQUE 35X1.5 FKM 70SH	O-RING 35X1.5 FKM 70SH	O-RING 35X1.5 FKM 70SH
4	5855	JOINT TORIQUE 87 X 2 NBR 70 SH	CYLINDER HEAD GASKET 87 X 2 NBR 70 SH	TORICA 87 X 2 NBR 70 SH
5	5873	ROULEMENT 628 8 2RS1 W64	ROLLING 628 8 2RS1 W64	COJINETE 628 8 2RS1 W64
6	2390	RONDELLE CUIVRE 6 X 12 X 1.5 UNITAIRE	COPPER WASHER 6 X 12 X 1.5 UNITAIRE	ARANDELA COBRE 6 X 12 X 1.5 UNIDAD
7	0547	VIS TH EP 6 X 30	TH EP SCREW 6 X 30	TORNILLO TH EP 6 X 30
8	5879	BOUGIE IWM27 / BR9ECMIX	SPARK PLUG IWM27 / BR9ECMIX	BUJIA IWM27 / BR9ECMIX
9	0592	VIS TH EP 6 X 8	TH EP SCREW 6 X 8	TORNILLO TH EP 6 X 8
10	5753	CYLINDRE 125 SE END	CYLINDER 125 SE END	CILINDRO 125 SE END
11	5863	JOINT PIPE ECHAPPEMENT 125 SE	EXHAUST FLANGE GASKET 125 SE	JUNTA TUBERA ESCAPE 125 SE
12	5862	BRIDE D' ECHAPPEMENT 125 SE	EXHAUST FLANGE 125 SE	BRIDA ESCAPE 125 SE
13	6888	JOINT TORIQUE 38X2.5 FKM 70SH	EXHAUST O-RING 38X2.5 FKM 70SH	O-RING 38X2.5 FKM 70SH
14	6648	JOINT EMBASE CYLINDRE 125 END 2T 0,3 MM	CYLINDER GASKET 125 END 2T 0,3 MM	JUNTA CILINDRO 125 END 2T 0,3 MM
14	6659	JOINT EMBASE CYLINDRE 125 END 2T 0,4 MM	CYLINDER GASKET 125 END 2T 0,4 MM	JUNTA CILINDRO 125 END 2T 0,4 MM
14	5876	JOINT EMBASE CYLINDRE 125 END 2T 0,5 MM	CYLINDER GASKET 125 END 2T 0,5 MM	JUNTA CILINDRO 125 END 2T 0,5 MM
14	6660	JOINT EMBASE CYLINDRE 125 END 2T 0,8 MM	CYLINDER GASKET 125 END 2T 0,8 MM	JUNTA CILINDRO 125 END 2T 0,8 MM
14	6661	JOINT EMBASE CYLINDRE 125 END 2T 1 MM	CYLINDER GASKET 125 END 2T 1 MM	JUNTA CILINDRO 125 END 2T 1 MM
14	6662	JOINT EMBASE CYLINDRE 125 END 2T 1,5 MM	CYLINDER GASKET 125 END 2T 1,5 MM	JUNTA CILINDRO 125 END 2T 1,5 MM
15	0656	VIS TH EP 6 X 16	TH EP SCREW 6 X 16	TORNILLO TH EP 6 X 16
16	7592	ENSEMBLE VALVE 125 SE KOKUSAN	EXHAUST VALVE ASSY 125 SE KOKUSAN	DESMODR. VALVULA JUEGO 125 SE KOKUSAN
17	6882	RONDELLE CALAGE 8X14X0.5	VALVE WASHER 8X14X0.5	ARANDELA REGLAGE 8X14X0.5
17	6883	RONDELLE CALAGE 8X14X0.3	VALVE WASHER 8X14X0.3	ARANDELA REGLAGE 8X12X0.5
18	5877	JOINT TORIQUE 8 X 2.80 FKM 610	O-RING 8 X 2.80 FKM 610	O RING 8 X 2.80 FKM 610
19	5875	POULIE CABLE COMMANDE DE VALVE 125 SE	CYLINDER PULLEY VALVE 125 SE	SOPORTE CABLE MANDO VALVULA 125 SE
20	M267	VIS CHC 4 X 16 0084 ZN NI TR	CHC SCREW 4 X 16 0084 ZN NI TR	TORNILLO 4 X 16 ALLEN ZN NI TR
21	6926	CAPOT POULIE DE VALVE 125 SE	EXHAUST VALVE COVER 125 SE	TAPA POLEA VALVULA 125 SE
22	1146	VIS CHC 4X8	CHC SCREW 4X8	TORNILLO CHC 4X8
23	1590	RONDELLE CONTACT 4X8	WASHER 4X8	ARANDELA CONICA 4X8
24	5867	COMMANDE VALVE 125 SE	EXHAUST VALVE COVER SUPPORT 125 SE	TAPA VALVULA 125 SE
25	2086	ECROU VALVE M6	VALVE NUT M6	TUERCA CON VALONA BASE LISA M6 6923
26	M272	ECROU EMBASE M8	CYLINDER NUT M8	TUERCA CON VALONA M8
27	5868	ENTRETOISE VALVE ECHAPPEMENT 125 SE	EXHAUST VALVE SPACER 125 SE	CASQUILLO JUNTA 125 SE
28	5874	JOINT LEVRE 10X14X3 TRK/NBR70	OIL SEAL 10X14X3 TRK/NBR70	RETEN 10X14X3 TRK/NBR70
29	5871	COUVERCLE DE VALVE GAUCHE 125 SE	LEFT VALVE COVER 125 SE	TAPA VALVULA IZQUIERDA 125 SE

*Sherco se réserve les droits de modification des références, merci de contrôler sur le portail Sherconetwork avant toute commande. - *Sherco reserves the right to make change on the references, please check on your Sherconetwork portal before ordering.
*Sherco se reserva el derecho para hacer modificaciones sobre las referencias. Por favor, verifica en el Sherconetwork antes de hacer un pedido.

Cylindre-Culasse Cylinder-Cylinder head / Cilindro-Culata

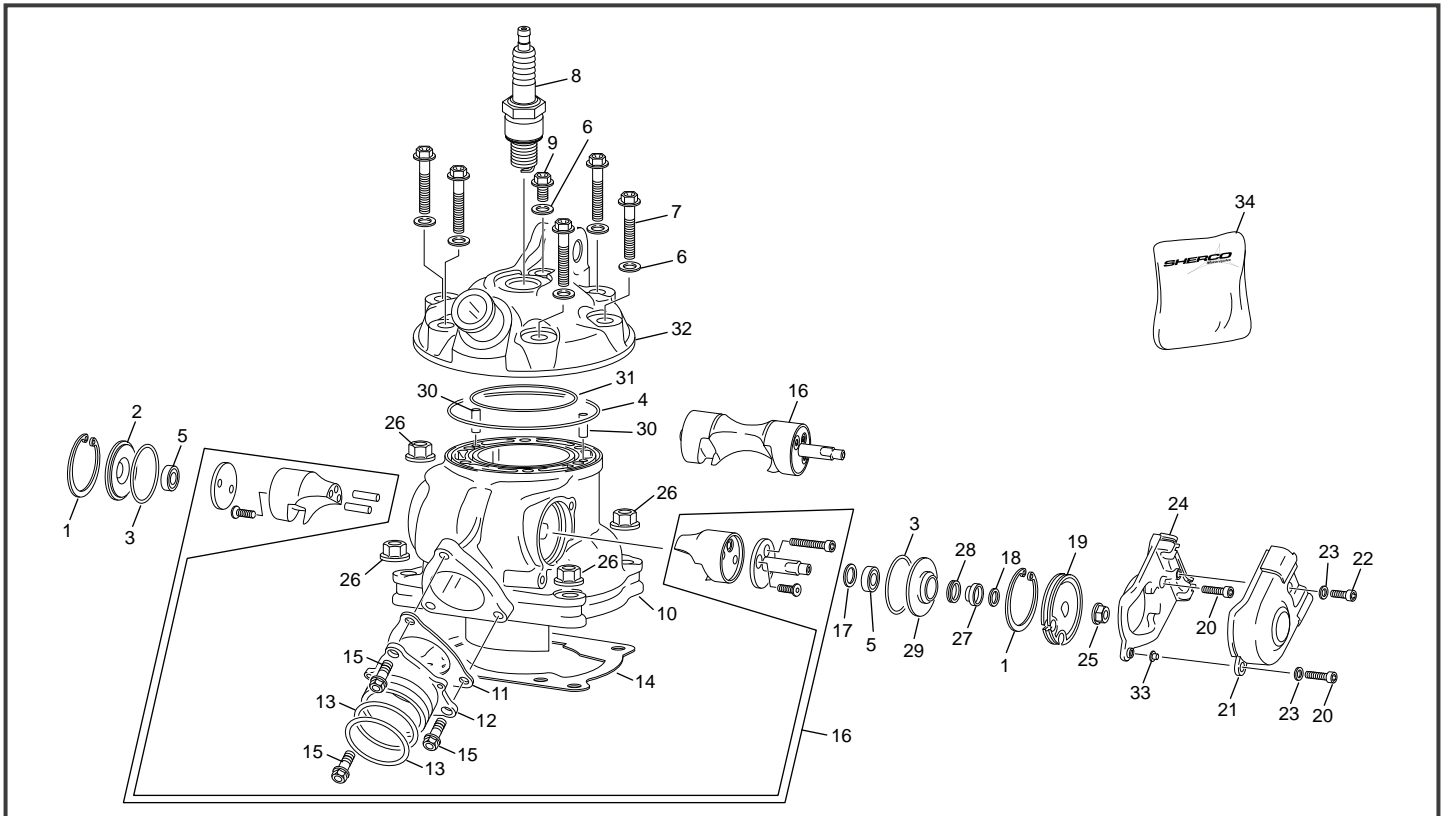

POS.	125 SE-R	FRANÇAIS	ENGLISH	ESPAÑOL
30	3946	AIGUILLE 4 X 11.8 BOUTS PLATS	NEEDLE NRB 4 X 11.8	AGUJA 4 X 11.8
31	5854	JOINT TORIQUE 62 X 2 FKM 70 SH	CYLINDER HEAD GASKET 62 X 2 FKM 70 SH	TORICA 62 X 2 FKM 70 SH
32	8361	CULASSE 125 SE MANGANESE	CYLINDER HEAD 125 SE MANGANESE	CULATA 125 SE MAGNESIO
33	8576	ENTRETOISE ACTUATEUR	SPACER ACTUATOR	ESPACIADOR ACTUADOR
34	7310	KIT JOINT HAUT MOTEUR 125 SE	KIT GASKET TOP ENGINE 125 SE	KIT JUNTA MOTOR PARTE SUPERIOR 125 SE

Boîte à clapet Reed valve / Caja de láminas

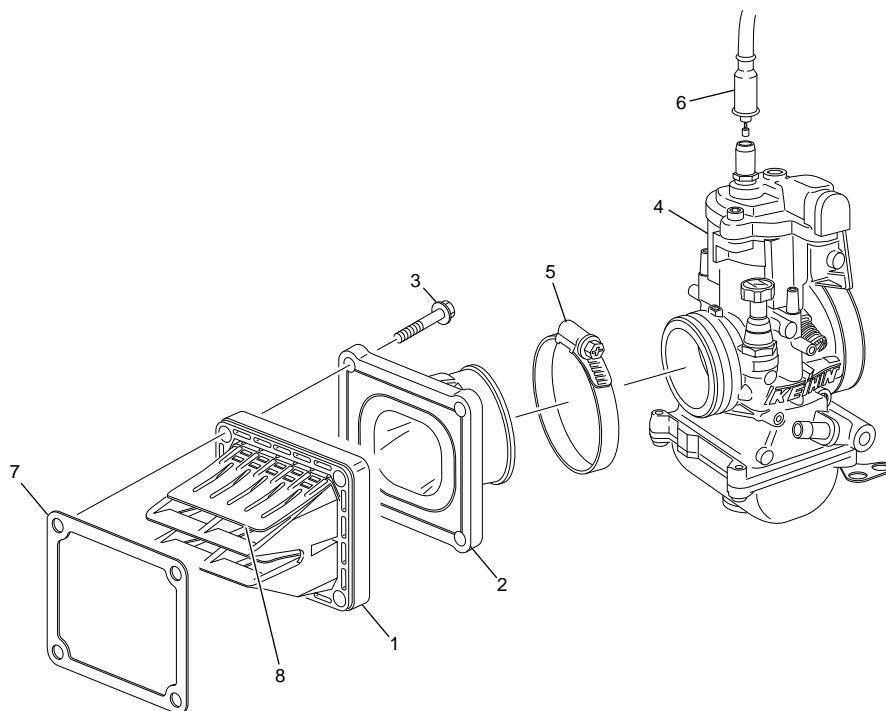

POS.	125 SE-R	FRANÇAIS	ENGLISH	ESPAÑOL
1	6848	BOITE CLAPET 125 2T COMPLETE	REED VALVE 125 2T COMPLETE	CAJA LAMINAS 125CC 2T CON AIR GUIDE
2	5897	PIPE ADMISSION 125 SE	INTAKE MANIFOLD 125 SE	PIPA ADM 125 SE
3	0970	VIS TH EP 6 X 25	TH EP SCREW 6 X 25	TORNILLO TH EP M6 X 25
4	10078	CARBUTATEUR KEIHIN 300 2T END	CARBULATOR KEIHIN 300 2T END	CARBURADOR KEIHIN 300 2T END
5	0595	COLLIER KC060 MANCHON CORP INJECTION END 450	COLLIER KC060 MANCHON CORP INJ.	BRIDA TOBERA KC060 CUERPO INYECCION END 450
6	4425	CABLE DE GAZ END 250	GAZ THROTTLE	CABLE DE GAS END 250
7	3866	JOINT BOITE CLAPET 250 2T END	REED VALVE GASKET	JUNTA CAJA LAMINAS 250 2T END
8	7232	KIT LAMELLES BOITE CLAPET 125 SE	PETAL KIT REED VALVE 125 SE	KIT LAMINAS CAJA LAMINAS 125 SE

Carburateur Carburetor / Carburador KEIHIN PWK 36

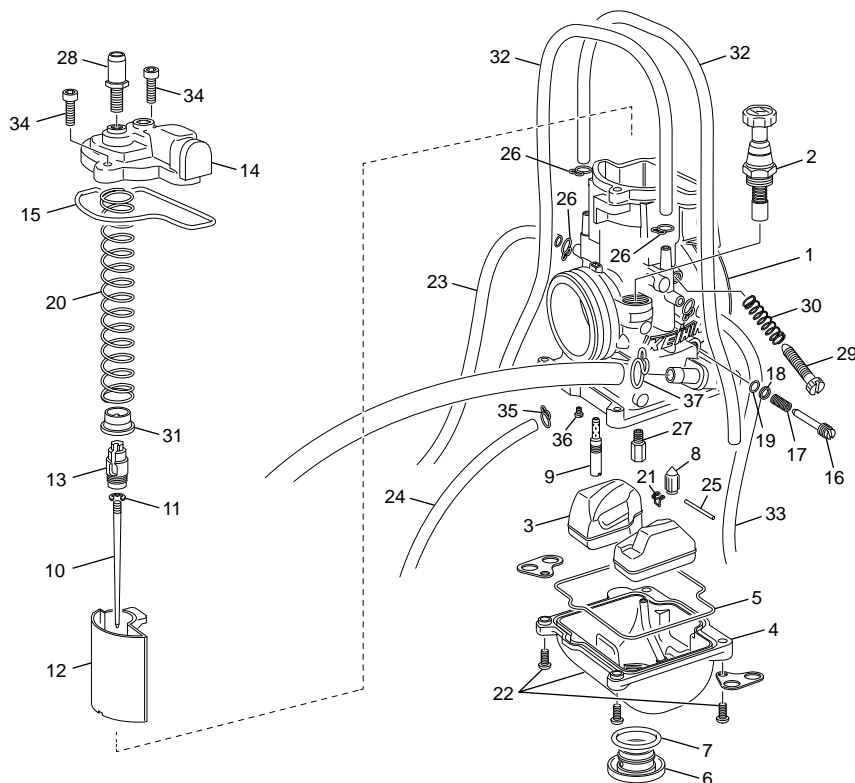

POS.	125 SE-R	FRANÇAIS	ENGLISH	ESPAÑOL
1	3863	CARBURATEUR KEIHIN PWK 36	KEIHIN CARBURATOR PWK 36	CARBURADOR KEIHIN PWK 36
2	5155	COMMANDE STARTER	COMPLETE VALVE STARTER	MANDO STARTER
3	5156	FLOTEUR DE CARBU KEIHIN 250/300 END 2T	CARBURATOR COMPLETE FLOAT KEIHIN	BOYA CARBU KEIHIN 250/300 END 2T
4	5157	CUVE CARBURATEUR KEIHIN 250/300 END 2T	BODY FLOAT CHAMBER KEIHIN	CUBA CARBURADOR KEIHIN 250/300 END 2T
5	5158	JOINT CUVE CARBURATEUR KEIHIN 250/300 END 2T	BODY FLOAT CHAMBER O-RING	JUNTA CUBA CARBURADOR KEIHIN 250/300 END 2T
6	5159	BOUCHON CUVE CARBURATEUR KEIHIN 250/300 END 2T	CAP DRAIN CARBURATEUR KEIHIN	TAPON CUBA CARBURADOR KEIHIN 250/300 END 2T
7	1334	JOINT TORIQUE CUVE	O-RING CAP DRAIN	TORICA CUBETA
8	5161	POINTEAU CARBU KEIHIN 250/300 END 2T	VALVE FLOAT KEIHIN	VALVOLA AGUJA KEIHIN 250/300 END 2T
9	1327	GICLEUR RALENTI 50 KEIHIN	IDLE JET 50 KEIHIN	CHICLE RALENTI 50 KEIHIN
9	1336	GICLEUR RALENTI 45 KEIHIN	IDLE JET 45 KEIHIN	CHICLE RALENTI 45 KEIHIN
9	1339	GICLEUR RALENTI 48 KEIHIN	IDLE JET 48 KEIHIN	CHICLE RALENTI 48 KEIHIN
9	1403	GICLEUR RALENTI 42 KEIHIN	IDLE JET 42 KEIHIN	CHICLE RALENTI 42 KEIHIN
9	4884	GICLEUR RALENTI 40 KEIHIN	IDLE JET 40 KEIHIN	CHICLE RALENTI 40 KEIHIN
9	5086	GICLEUR RALENTI 38 KEIHIN	IDLE JET 38 KEIHIN	CHICLE RALENTI 38 KEIHIN
10	6891	AIGUILLE CARBU KEIHIN NTEE	NEEDLE KEIHIN NTEE	AGUJA CARBU NTEE
10	7149	AIGUILLE CARBU KEIHIN NTEG	NEEDLE KEIHIN NTEG	AGUJA CARBU NTEG
11	1342	CLIP AIGUILLE CARBU KEIHIN	CLIP NEEDLE CARBU KEIHIN	CLIP AGUJA CARBU KEIHIN
12	5087	BOISSEAU KEIHIN 5.5	VALVE THROTTLE KEIHIN 5.5	CAMPANA KEIHIN 5.5
12	5088	BOISSEAU KEIHIN 6	VALVE THROTTLE KEIHIN 6	CAMPANA KEIHIN 6
12	5089	BOISSEAU KEIHIN 7	VALVE THROTTLE KEIHIN 7	CAMPANA KEIHIN 7
12	5184	BOISSEAU KEIHIN 65	VALVE THROTTLE KEIHIN 65	CAMPANA KEIHIN 65
13	5163	FIXATION CÂBLE KEIHIN 250/300 END 2T	HOLDER CABLE KEIHIN	TUERCA AJUSTE CABLE GAS 250/300 END 2T
14	5164	CHAPEAU CARBURATEUR KEIHIN 250/300 END 2T	TOP CARBURATOR KEIHIN	TAPA CARBURATOR KEIHIN 250/300 END 2T
15	5165	JOINT COUVERCLE BOISSEAU KEIHIN 250/300 END 2T	GASKET TOP CARBURATOR KEIHIN	JUNTA TAPA CARBURADOR KEIHIN 250/300 END 2T
16	5166	VIS REGUL ESSENCE CARBU KEIHIN 250/300 END 2T	ADJUST AIR SCREW KEIHIN	TORNILLO AIRE KEIHIN 250/300 END 2T
17	5167	RESSORT VIS ESSENCE CARBU KEIHIN 250/300 END 2T	SPRING AIR SCREW CARBU KEIHIN	MUELLE TORNILLO AIRE KEIHIN 250/300 END 2T
18	5168	RONDILLE VIS ESSENCE CARBU KEIHIN 250/300 END 2T	WASHER AIR SCREW CARBU KEIHIN	ARANDELA MUELLE TORNILLO AIRE KEIHIN 250/300 END 2T
19	5169	O RING VIS ESSENCE CARBU KEIHIN 250/300 END 2T	O RING CARBU KEIHIN	O RING MUELLE TORNILLO AIRE KEIHIN 250/300 END 2T
20	5170	RESSORT CARBURATEUR KEIHIN 250/300 END 2T	SPRING TROTTLE RETURN KEIHIN	MUELLE CARBURADOR KEIHIN 250/300 END 2T
21	5171	CLIP VALVE KEIHIN 250/300 END 2T	CLIP FLOAT VALVE KEIHIN	CLIP VALVULA KEIHIN 250/300 END 2T
22	5172	VIS FIXATION CUVE KEIHIN 250/300 END 2T	BODY FLOAT CHAMBER SCREW KEIHIN	TORNILLO FIJACION CUBA KEIHIN 250/300 END 2T
23	5173	DURITE CARBURATEUR KEIHIN END 250/300 2T	VINYLE PIPE BOWL KEIHIN	TUBO GASOLINA CARBURADOR KEIHIN END 250/300 2T
24	5188	DURITE CARBURATEUR KEIHIN END 250/300 2T	VINYLE PIPE BOWL KEIHIN	TUBO GASOLINA CARBURADOR KEIHIN END 250/300 2T
25	1351	AXE BALANCIER FLOTEUR CARBU KEIHIN	PIN ARM CARBU KEIHIN	EJE BALANCIER FLOTADOR CARBU KEIHIN
26	5187	CLIP DURITE CARBU KEIHIN END 250/300 2T	CLIP TUBE KEIHIN END 250/300 2T	CLIP TUBOS KEIHIN END 250/300 2T

*Sherco se réserve les droits de modification des références, merci de contrôler sur le portail Sherconetwork avant toute commande. - *Sherco reserves the right to make change on the references, please check on your Sherconetwork portal before ordering.
*Sherco se reserva el derecho para hacer modificaciones sobre las referencias. Por favor, verifica en el Sherconetwork antes de hacer un pedido.

Carburateur Carburetor / Carburador KEIHIN PWK 36

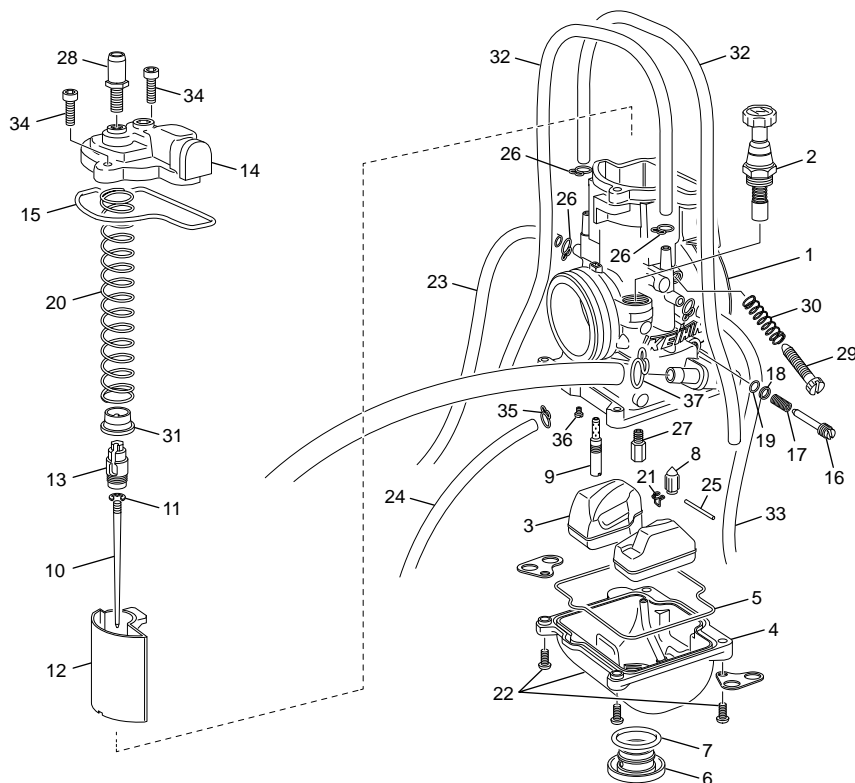

POS.	125 SE-R	FRANÇAIS	ENGLISH	ESPAÑOL
27	1402	GICLEUR PRINCIPAL 115 KEIHIN	MAIN JET 115 KEIHIN	CHICLE PRINCIPAL 115KEIHIN
27	4883	GICLEUR PRINCIPAL 165 KEIHIN	MAIN JET 165 KEIHIN	CHICLE PRINCIPAL 165 KEIHIN
27	5178	GICLEUR PRINCIPAL 160 KEIHIN	MAIN JET 160 KEIHIN	CHICLE PRINCIPAL 160 KEIHIN
27	5179	GICLEUR PRINCIPAL 168 KEIHIN	MAIN JET 168 KEIHIN	CHICLE PRINCIPAL 168 KEIHIN
27	5180	GICLEUR PRINCIPAL 170 KEIHIN	MAIN JET 170 KEIHIN	CHICLE PRINCIPAL 170 KEIHIN
27	5181	GICLEUR PRINCIPAL 175 KEIHIN	MAIN JET 175 KEIHIN	CHICLE PRINCIPAL 175 KEIHIN
27	6325	GICLEUR PRINCIPAL 162 KEIHIN	MAIN JET 162 KEIHIN	CHICLE PRINCIPAL 162 KEIHIN
28	5175	GUIDE CÂBLE KEIHIN 250/300 2T END	HOLDER CABLE KEIHIN 250/300 2T END	FIJACION CABLE GAS KEIHIN GUIDE 250/300 2T END
29	1356	VIS REGUL GAS CARBU KEIHIN	STOP SCREW CARBU KEIHIN	TORNILLO RALENTI KEIHIN
30	1357	RESSORT VIS REGUL GAS CARBU KEIHIN	SPRING IDLE SPEED CARBU KEIHIN	MUELLE TORNILLO RALENTI KEIHIN
31	5176	RONDELLE BLOQUAGE BOISSEAU KEIHIN END 250/300 2T	COLLAR THROTTLE VALVE KEIHIN END 250/300 2T	CASQUILLO NYLON MUELLE KEIHIN 250/300 2T END
32	5186	DURITE CARBURATEUR KEIHIN END 250/300 2T	VINYLE PIPE BOWL KEIHIN END 250/300 2T	TUBO GASOLINA CARBURADOR KEIHIN END 250/300 2T
33	5189	DURITE CARBURATEUR KEIHIN END 250/300 2T	VINYLE PIPE BOWL KEIHIN END 250/300 2T	TUBO GASOLINA CARBURADOR KEIHIN END 250/300 2T
34	5177	VIS FIXATION COUVERCLE BOISSEAU KEIHIN END	VALVE THROTTLE FIXATION SCREW KEIHIN END	TORNILLO FIJACION TAPA CAMPANA KEIHIN END
35	5174	CLIP DURITE CARBU KEIHIN END 250/300 2T	CLIP TUBE CARBU KEIHIN END 250/300 2T	CLIP TUBOS KEIHIN END 250/300 2T
36	5130	GICLEUR STARTER 50 KEIHIN	STARTER JET 50 KEIHIN	CHICLE STARTER 55 KEIHIN
36	5182	GICLEUR STARTER 85 KEIHIN	STARTER JET 85 KEIHIN	CHICLE STARTER 85 KEIHIN
37	5410	COLLIER SERRAGE DOUBLE FIL	HOSE SEEGER	SEEGER TUBOS

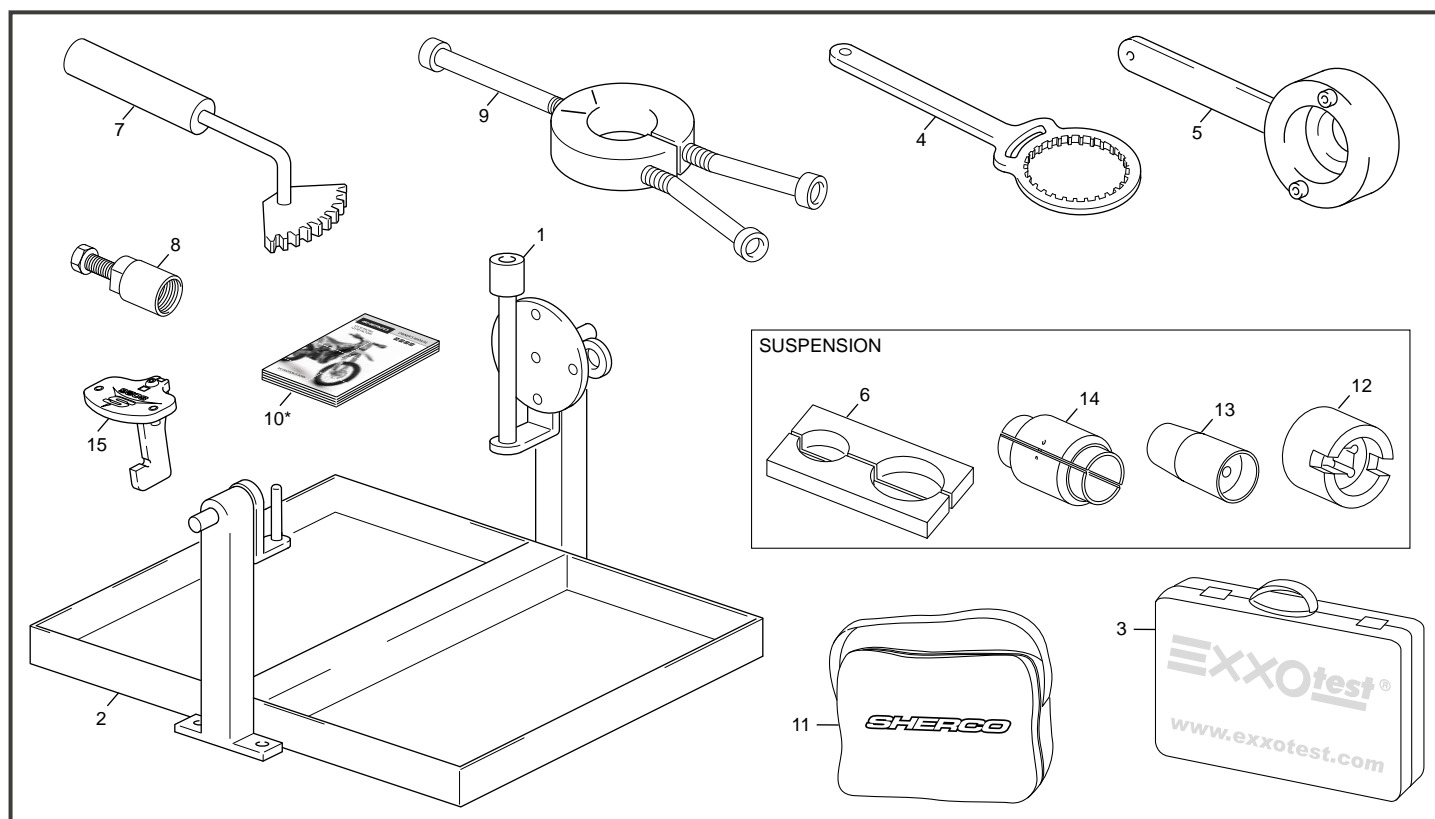

POS.	125 SE-R	FRANÇAIS	ENGLISH	ESPAÑOL
1	R455	OUTIL SUPORT MOTEUR	OUTIL SUPORT MOTEUR	UTIL SOPORTE MOTOR
2	R481	SERVANTE	SERVANTE	BANDEJA
3	8561	KIT OUTIL DIAGNOSTIC INJECTION SYNERJECT	TOOL DIAGNOSTIC INJECTION SYNERJECT KIT	KIT UTILLAJE DIAGNOSTICO INYECCION SYNERJECT
4	1814	OUTIL CLOCHE EMBRAYAGE END 450	OUTIL CLOCHE EMBRAYAGE END 450	UTIL CAMPANA EMBRAGUE 250
5	1815	OUTIL ALLUMAGE	OUTIL ALLUMAGE	UTIL ENCENDIDO 250
6	5031	OUTIL 1/2 MORS DE TUBE WP 48	OUTIL 1/2 MORS DE TUBE WP 48	HERRAMIENTA FIJACION TUBOS WP
7	1817	OUTIL BLOC PIGNON PRIMAIRE	OUTIL BLOC PIGNON PRIMAIRE	UTIL PINION PRIMARIO
8	R462	EXTRACTEUR VOLANT	EXTRACTEUR VOLANT	EXTRACTOR VOLANTE
9	R464	EXTRACTEUR ANNEAU INTERNE 450	EXTRACTEUR ANNEAU INTERNE 450	EXTRACTOR ANILLO INTERIOR
10	8701*	MANUEL DU PROPRIETAIRE SE 125	MANUEL DU PROPRIETAIRE SE 125	MANUAL PROPIETARIO SE 125
11	0726	TROUSSE OUTILS	TROUSSE OUTILS	RIÑONERA HERRAMIENTAS
12	7189	OUTIL BOUCHON XPLOR	OUTIL BOUCHON XPLOR	UTIL TAPON XPLOR
13	5029	OUTIL GUIDE JOINT D48	OUTIL GUIDE JOINT D48	HERRAMIENTA GUIA JUNTA WP 48
14	5028	OUTIL EMMANAGEMENT D48	OUTIL EMMANAGEMENT D48	HERRAMIENTA AYUDA MARTILLO WP 48
15	8026	OUTIL VALVE 125	VALVE TOOL 125	UTIL VALVULA 125

SHERCO



WWW.SHERCO.COM

